



EARTHCRAFT MULTIFAMILY

TECHNICAL GUIDELINES



Table of Contents

TABLE OF FIGURES	4
INTRODUCTION	6
About EarthCraft	6
About the EarthCraft Multifamily V6.5 Technical Guidelines	7
About the EarthCraft Multifamily Workbook and Manual	10
Workbook Sections and Descriptions	11
Disclaimer and Notices	14
Acknowledgements	15
EarthCraft Contact Information	16
SITE PLANNING (SP)	17
Site Selection (SP 1)	18
Site Design (SP 2)	20
Site Preparation and Preservation Measures (SP 3)	26
Alternative Transportation Accommodations (SP 4)	33
CONSTRUCTION WASTE MANAGEMENT (CW)	34
RESOURCE EFFICIENCY (RE)	37
Resource Efficient Design (RE 1)	38
Advanced Framing Products (RE 2)	41
Local, Recycled and/or Natural Content Materials (RE 3)	44
Building Reuse (RE 4)	48
DURABILITY AND MOISTURE MANAGEMENT (DU)	49
Products and Applications (DU 1)	50
Moisture Management (DU 2)	68
INDOOR AIR QUALITY (IAQ)	77
Combustion Safety (IAQ 1)	78

Indoor Pollutant Control (IAQ 2)	80
CONFIRMATION	85
HIGH PERFORMANCE BUILDING ENVELOPE (BE)	86
Energy Code and Energy Performance (BE 0)	87
Air Sealing (BE 1)	90
Blower door test (BE 2)	110
Insulation (BE 3)	113
Windows (BE 4)	132
Roof (BE 5)	141
ENERGY EFFICIENT SYSTEMS (ES)	143
Heating and Cooling (ES 1)	144
Ductwork/Air handler (ES 2)	152
Duct Leakage Test Results (ES 3)	164
Ventilation (ES 4)	167
Water Heater (ES 5)	177
Lighting and Appliances (ES 6)	180
Common Area Lighting/Appliances (ES 7)	183
WATER EFFICIENCY (WE)	185
Indoor Water Use (WE 1)	186
Outdoor Water Use (ES 2)	192
EDUCATION AND OPERATIONS (EO)	197
Education (EO 1)	198
Operations and Management (EO 2)	200
Third Party Programs (EO 3)	202
INNOVATION (IN)	205
Innovation	206

Table of Figures

Figure 1: Waste grinder.....	31
Figure 2: 2-stud corner.....	38
Figure 3: Ladder T-wall.....	39
Figure 4:Ladder T-wall.....	39
Figure 5:Insulated concrete form (ICF).....	41
Figure 6: Structural insulated panel (SIP).....	43
Figure 7: Example of manufacturer's specifications for drainage plane installation.....	50
Figure 8: Steps 1 & 2: Preparing house wrap or builder paper.....	51
Figure 9: Step 3: Create back dam or slope away from interior.....	52
Figure 10: Step 4: Pan flashing - Option 1.....	52
Figure 11: Step 4: Install plan flashing - Option 2.....	53
Figure 12: Step 5: Finishing window installation.....	53
Figure 13: Roof gutters connected to downspout for proper drainage.....	55
Figure 14: Membrane protection of roof valley.....	56
Figure 15: Metal coil stock flashing formed to valley.....	57
Figure 16: Step 1: Kick-out flashing beginning run of step flashing.....	58
Figure 17: Step 2: Successive sections of step flashing integrated with courses of shingles.....	58
Figure 18: Step 3: Drainage plane material covers step flashing.....	59
Figure 19: Continuous Termite Shield.....	60
Figure 20: Enclosed crawl space with insulation along walls.....	62
Figure 21: Base flashing at the bottom of exterior walls.....	63
Figure 22: Site-built vented rain screen.....	65
Figure 23: Slab installed over 4" of clean aggregate with a vapor barrier with overlapping seams. (Inset) A geotextile drainage mat may be used in place of the gravel when installed on a 4" bed of sand.....	68
Figure 24: Foundation drain on top of footing.....	70
Figure 25: Capillary break Installation.....	72
Figure 26: Foundation drain next to footing.....	74
Figure 27: Foundation drain next to footing.....	74
Figure 28: Capillary break between ground and footing.....	76
Figure 29: Sealed bottom plates.....	90
Figure 30: Cantilevered floor blocking.....	91
Figure 31: Attic kneewall blocking.....	92
Figure 32: Blocking at change in ceiling height.....	93
Figure 33: Attic knee wall blocking.....	94
Figure 34: Bath fan vent sealed at rim joist.....	95
Figure 35: Air sealing at insulated subfloor.....	95
Figure 36: Air sealing at HVAC boot in insulated ceiling.....	96
Figure 37: Air sealing at can light.....	96
Figure 38: Air sealing at plumbing penetration in subfloor.....	97
Figure 39: Sealing boot to subfloor.....	98
Figure 40: Air sealing around window and door rough openings.....	98
Figure 41: Attic pull-down stairs with foam board.....	99
Figure 42: Attic pull-down stairs with batt insulation.....	99
Figure 43: Rigid air barrier at chase on insulated wall.....	100
Figure 44: Air barrier behind tub.....	101
Figure 45: Insulated fireplace chase.....	103
Figure 46: Kneewall door weather-stripping.....	104
Figure 47: Pull-down stairs weather-stripping.....	105
Figure 48: Can light installation.....	106
Figure 49: Top plate sealed.....	108
Figure 50: Sample floor plan.....	110
Figure 51: Blower door.....	111
Figure 52: Floor insulation supports.....	113
Figure 53: Cantilevered floor insulation.....	114

Figure 54: Foundation wall insulation.....	115
Figure 55: Full insulation over top plate.....	116
Figure 56: Raised joist to accommodate for insulation under attic platform.....	117
Figure 57: Energy heel truss (top), raised top plate (bottom).....	118
Figure 58: Attic kneewall insulation and blocking.....	119
Figure 59: RESNET Protocol for Fiberglass Batt Insulation Grading.....	121
Figure 60: Slab edge insulation for floating slab.....	122
Figure 61: Insulated corner.....	123
Figure 62: Insulated headers.....	124
Figure 63: Enclosed crawl space with insulation along walls.....	125
Figure 64: Basement wall insulation.....	126
Figure 65: Exterior Wall and Band Joist Insulation.....	127
Figure 66: Attic kneewall insulation.....	129
Figure 67: Insulated Roofline.....	130
Figure 68: NFRC window label.....	132
Figure 69: Window overhang.....	137
Figure 70: Solar shade screen.....	138
Figure 71: Seasonal solar position.....	139
Figure 72: Common mastic locations.....	152
Figure 73: Common mastic locations (1).....	153
Figure 74: Common mastic locations (2).....	153
Figure 75: Return air pathways.....	156
Figure 76: Correct (top) and incorrect (bottom) ductwork installation.....	158
Figure 77: Correct (top) and incorrect (bottom) ductwork installation.....	159
Figure 78: Ducts in conditioned space.....	161
Figure 79: Duct installation at plenum.....	162
Figure 80: Duct leakage tester.....	165
Figure 81: Radon vent pipe.....	174

Introduction

About EarthCraft

EarthCraft™ green building programs, which were first developed in 1999 as a partnership between the Greater Atlanta Home Builders Association and Southface Energy Institute, are designed to specifically address the challenging energy, water and climate conditions of the Southeast.

EarthCraft certification helps ensure that buildings and communities in the region meet strict criteria for saving energy and water, ensuring high indoor air quality, and protecting our land and natural resources. To achieve an EarthCraft certification, a building is required to undergo independent third-party verification by a qualified EarthCraft Technical Advisor who confirms the building meets all program requirements.

The family of EarthCraft green building programs includes:

EarthCraft House



The EarthCraft House™ program is designed to certify new construction single-family detached homes, townhomes and duplexes. Any size or type of home can be certified because builders are able to select which program measures are best suited for the project while meeting minimum thresholds for performance.

EarthCraft Renovation



EarthCraft Renovation™ offers remodelers and contractors the unique opportunity to certify projects of various size and complexity in renovation, remodeling and expansion. Renovation projects receive an assessment and recommendations for specific renovation techniques to address environmental performance areas.

EarthCraft Multifamily



The EarthCraft Multifamily™ program is designed to certify new or renovated low-rise, mid-rise and high-rise residential buildings. Multifamily projects are designed to address environmental performance, livability and affordability for each unit as well as the structure as a whole.

EarthCraft Communities



The EarthCraft Communities™ program is designed to certify sustainably planned and developed communities in urban, suburban or rural areas. The program offers a holistic approach to sustainable development projects.

EarthCraft Light Commercial



The EarthCraft Light Commercial™ program is designed to certify new or renovated small-scale commercial buildings of 15,000 square feet or less. Projects receive hands-on support during the design and construction process that focuses on energy- and water-efficient design strategies.

About the EarthCraft Multifamily V6.5 Technical Guidelines

The EarthCraft Multifamily V6.5 Technical Guidelines apply to all new construction, adaptive reuse, and gut rehab projects in the EarthCraft Multifamily program permitted on or after January 1, 2022. The Technical Guidelines must be used in conjunction with the EarthCraft Multifamily Version 6.5 Workbook and are intended to provide explanations for each line item on the Worksheet.

Projects seeking additional clarity beyond what is provided in the Technical Guidelines should consult the Viridiant staff and/or an EarthCraft Technical Advisor for additional information.

All local building codes must be met. When local building codes are more stringent than the Technical Guidelines and Worksheet, the local code must be followed. Should the EarthCraft Technical Guidelines and Worksheet conflict with local code, the local code must be followed. The EarthCraft Builder must notify the EarthCraft Technical Advisor of any changes required for the project to meet local codes.

Additions and updates are made by EarthCraft to the Technical Guidelines as needed and requested. Technical Guidelines versions may be determined by the version in the lower left corner of the document. The latest Technical Guidelines are available for free download from the EarthCraft website at www.viridiant.org. To make recommendations for improvements and updates to the Technical Guidelines, please contact Viridiant or an EarthCraft Technical Advisor.

Legend

The Technical Guidelines are organized by workbook category. Each line item on the EarthCraft V6.5 Worksheet is listed in the Technical Guidelines with the following supplemental information. To determine which line items are required by the program and the point values associated with line items, the EarthCraft V6.5 Worksheet must be reviewed.

Criteria

Criteria cover the requirements for the specified measure detailing any specific information necessary for meeting the line item. All criteria must be implemented to qualify for the line item on the EarthCraft Multifamily V6.5 Worksheet.

Materials and methods described are representative of typical strategies that meet the intent of the criteria, but do not represent all strategies that may be used. The builder may request permission from EarthCraft, through the EarthCraft Technical Advisor, to meet the intent of the credit using a different approach; approval must be requested and approved prior to implementation.

Line items with multiple options will be identified through the use of numbers or letters in italics with specific criteria associated with each number or letter. Numbered items indicate criteria that may be added together on the EarthCraft Multifamily V6.5 Worksheet for cumulative points; Lettered items indicate criteria that may not be added together (the project may only receive credit for one of the options listed). For example, under SP1.0: Type of Site, all three measures (1, 2 and/or 3) may be met or only one measure may be met as a site can be a brownfield, previously developed and an infill site, or it may only be one of those. Under SP 1.1: Dwelling Units Per Acre, only one item, either A, B, or C, may be counted towards EarthCraft certification.

Clarifications

Clarifications provide case-specific clarifications of criteria implementation, such as trade-offs allowed within the program.

Exemptions

Exemptions list specific exemptions to credit requirements.

Examples

Examples provide examples of criteria implementation and are often used to demonstrate calculations.

Additional Resources

Additional Resources are intended to provide a quick reference for applicable resources that may be used for additional information pertaining to criteria. Additional Resources are not intended to be an exhaustive list of references and products that may be used to meet criteria.

Confirmation

When verifying line items on an EarthCraft project, EarthCraft Builders and EarthCraft Technical Advisors should reference the guidelines to ensure all requirements have been met. The Confirmation language articulates when the official confirmation activity should take place and how, and whether any documentation is required. All criteria must be confirmed before points are awarded on the EarthCraft Multifamily V6.5 Worksheet.

Confirmation occurs primarily at either the pre-drywall inspection, the final inspection, or at both the pre-drywall inspection and final inspection. Each confirmation type confirms compliance of criteria as listed in the criteria and clarifications sections of each line item. The type(s) of confirmation is listed based on a set of standard options as follows:

- Visual
 - Indicates confirmation of criteria via direct visual inspection by the EarthCraft Technical Advisor.
 - The type of visual confirmation required is dependent on the criteria and should at a minimum include a direct visual inspection by the EarthCraft Technical Advisor to confirm criteria were met. For example, if the project is pursuing credit for recycling waste, in addition to reviewing the documented waste management plan provided by the builder, the EarthCraft Technical Advisor will visually confirm that materials are being recycled on site by seeing recycling signage and separation piles and confirming no materials meant for recycling are in the trash (e.g., no contractor beverage containers are in the dumpster).
 - If unable to confirm compliance of criteria through this option, the EarthCraft Technical Advisor may require documentation or photo confirmation.
- Verbal
 - Indicates confirmation of criteria via direct conversation between the builder and EarthCraft Technical Advisor
 - The type of verbal confirmation required is dependent on the criteria and should at a minimum include a reasonable explanation by the builder of how the criteria were met.
 - If unable to confirm compliance of criteria through this option, the EarthCraft Technical Advisor may require documentation or photo confirmation.
 - If the EarthCraft Technical Advisor identifies any discrepancy between the verbal description provided and visual inspections performed on the project, the visual confirmation rules. For example, if the builder verbally confirms all waste was disposed of in a state approved landfill, but the EarthCraft Technical Advisor sees a bury pit on site, the project will not be eligible for certification.
- Documentation
 - Indicates confirmation of criteria via documentation provided by the builder and reviewed by the EarthCraft Technical Advisor
 - The type of documentation required is dependent on the criteria. For example, criteria dependent on calculations should be demonstrated through the documentation of those calculations. Other common forms of documentation include: site plans, house plans, product specifications, product warranties, test

- results, etc. The documentation must provide sufficient information for the EarthCraft Technical Advisor to confirm the criteria were met and should not require the EarthCraft Technical Advisor to conduct further research or calculations.
- Documentation, as specified in the confirmation area for each line item, may either be:
 - Presented at or before the applicable inspection and kept on file by the builder for a minimum of three years.
 - Submitted to the EarthCraft Technical Advisor at or before the applicable inspection and kept on file by the EarthCraft Technical Advisor for a minimum of three years.
 - Documentation applicable to multiple projects may be presented and/or submitted once and kept on file by the appropriate party. Updates to documentation are required whenever methods or materials used are changed. EarthCraft Technical Advisors are required to verbally reconfirm documentation accuracy at each inspection.
 - When criteria are clearly met through visual inspection the EarthCraft Technical Advisor may wave documentation. For example, if the EarthCraft Technical Advisor visually confirms cork flooring has been installed on 30% of the floor area, s/he may wave documentation.
 - Photo
 - Indicates confirmation of criteria via photo documentation provided by the builder and reviewed by the EarthCraft Technical Advisor.
 - Photos must be submitted by the builder to the EarthCraft Technical Advisor at or before the applicable inspection and kept on file by the EarthCraft Technical Advisor for a minimum of three years.
 - Photos must clearly illustrate criteria being confirmed as well as location in the project. At a minimum, photo documentation must:
 - Provide evidence of each measure outlined in the criteria.
 - Show both the general location and the specific strategy.
 - Be date stamped.
 - Testing
 - Indicates confirmation of criteria via diagnostic testing performed primarily by the EarthCraft Technical Advisor. Tests not performed by the EarthCraft Technical Advisor must be performed by a third-party approved by the EarthCraft Technical Advisor and not having a direct conflict of interest. For example, HVAC flow testing must be performed by a third-party not associated with the HVAC contractor. The EarthCraft Technical Advisor must review test results for reasonableness.
 - Proper industry-accepted training and testing protocol must be followed in addition to the specific measures outlined in the following guidelines, including properly calibrated and maintained equipment. A specific example of industry-accepted testing protocols that must be followed in addition to the guidelines include:
 - Flow testing: the third-party must use a properly calibrated flow hood, flow grid or anemometer in accordance with relevant AABC, NEBB or ASHRAE procedures.

About the EarthCraft Multifamily Workbook and Manual

Objective

The EarthCraft Multifamily Workbook and the EarthCraft Manual provide project teams with detailed information and guidance on program implementation. The worksheet is the primary tool used to show compliance for an EarthCraft Multifamily project. The most recent worksheet should be downloaded from the EarthCraft website before each design review or a new project seeks program compliance. This Excel workbook includes a cover sheet indicating the project's score, an instructions tab for how to properly fill out and track the worksheet, and the worksheet which illustrates which strategies the project has incorporated. The EarthCraft Manual outlines roles and responsibilities for all project participants as well as a detailed process for certifying a project.

Instructions

The EarthCraft Builder or project team representative must complete an EarthCraft worksheet to show that the project will qualify for certification. The EarthCraft Multifamily Worksheet is an Excel spreadsheet that can be downloaded from www.viridiant.org. Each project seeking certification must complete a worksheet unique to the project. The EarthCraft project team analyzes the project prior to construction and selects the credits that they plan to achieve by placing the appropriate score next to each point value. Viridiant reviews the worksheet at the Design Review, Pre-Drywall Inspection, and Final Inspection to clarify any questions that may arise during implementation, collects the required documentation (varies per line item), and verifies specific measures (varies per line item).

Workbook Sections and Descriptions

Site Planning (SP)

The location of a project and the plan for the area around that project can have a significant impact on both the resident's quality of life and on the environment. Selecting an appropriate site for a project is essential to creating more walkable, livable communities with efficient transportation. One can also improve the air quality in a neighborhood, help manage stormwater, lower energy bills and increase property values simply by protecting and restoring trees on a site. Planning for construction on a site can prevent soil loss and water pollution by reducing erosion and properly controlling for stormwater.

The Site Planning category of the EarthCraft program focuses on actions that a project team can take to minimize the direct impact of a building site on the environment. These actions range from protecting excavated topsoil from erosion to reducing lot size. Projects may also implement additional site planning measures to promote accessibility to public amenities such as mass transit and parks or using degraded sites such as brownfields.

Construction Waste Management (CW)

Each year, more than 130 million tons of debris from construction sites is sent to landfills in the United States, which accounts for one quarter of the non-industrial waste in the United States. However, most construction debris is recyclable. By taking simple steps to recycle construction waste, a builder will reduce the amount of waste incinerated or placed in landfills, preventing pollution, and conserving and protecting our natural resources for future generations.

The Construction Waste Management category of the EarthCraft program focuses on ways an EarthCraft Builder can reduce the amount of recyclable construction waste sent to landfills and reduce the need to extract virgin raw materials. The waste management strategies include grinding and repurposing wood scraps and gypsum, crushing concrete to use as aggregate and recycling metals.

Resource Efficiency (RE)

Forests provide habitats to diverse animal species, offer watershed protection, prevent soil erosion, and help maintain the water cycle. EarthCraft encourages the protection of forests through resource efficient design. By taking the time to design a project to use less wood and by practicing simple measures to ensure that wood on site is used properly, a new construction project can reduce its impact to the environment as well as cost less money to build.

EarthCraft projects can meet the requirements of the Resource Efficiency category through methods such as designing buildings with 2' dimensions, employing advanced framing techniques and providing clear framing plans and cut lists to contractors. These methods not only reduce the amount of lumber used on site, but also save money through reduced material costs, reduced tipping fees and increased customer satisfaction including improving the project's energy efficiency.

Building materials come from a variety of sources, not all of which are environmentally friendly. The EarthCraft program strives to reduce the impact buildings have on the environment, including the impacts that result from the extraction and manufacture of materials used in construction. By choosing certain building materials, an EarthCraft project can conserve natural resources, prevent unnecessary waste and reduce pollution associated with manufacturing and transporting of materials.

Durability and Moisture Management (DU)

An important aspect of building sustainably is ensuring durability throughout a project's life cycle. The EarthCraft Multifamily program recognizes that proper design and installation are integral to building a durable building with minimal moisture management issues. Reducing the life cycle costs due to maintenance, repair and replacement decreases the impact that construction, and reconstruction, has on the environment. The durability and moisture management section includes items that improve long-term durability, occupant health and comfort.

Indoor Air Quality (IAQ)

Because the average American spends over 90% of their time indoors, creating a healthy and comfortable indoor environment is an important issue for any resident, especially those who are more sensitive to air quality such as children, seniors, and individuals with respiratory problems and compromised immune systems. EarthCraft project teams can improve the health of occupants by installing materials with fewer pollutants, flushing any pollutants out through proper ventilation, and controlling moisture to eliminate mold growth.

The Indoor Air Quality category consists of items that aim to reduce the presence of pollutants and contaminants in the air inside a building. Reducing or eliminating the presence of manmade pollutants such as volatile organic compounds or natural occurring carcinogens such as radon leads to a healthier environment for occupants.

High Performance Building Envelope (BE)

One of the key elements to any energy efficient building is constructing a proper building envelope by sealing for air leaks, properly installing insulation and using high-quality windows. The building envelope is the barrier that separates the building's conditioned space from unconditioned space or the outside. The building envelope consists of two parts - an air barrier and a thermal barrier (insulation) that must be both continuous and contiguous (touching each other). In a typical residence, the building envelope consists of the roof or ceiling, walls, windows, doors, and floor or foundation. Buildings account for about 40% of all energy use in the United States. EarthCraft encourages an energy efficient building envelope to reduce this impact.

Energy Efficient Systems (ES)

Constructing an energy-efficient development provides a variety of benefits to both occupants and to the environment. Once the building envelope has been designed, evaluating heating and cooling systems, ventilation, domestic water heating, lighting, and appliances, using the house-as-a-system approach is critical to achieving high performance buildings.

An energy efficient home not only saves a resident on their utility bills but also improves their comfort and health. Comfort is a function of air temperature, relative humidity, and radiant heating and cooling, all of which are impacted by the energy systems used in the project. In addition, using less energy reduces the need to extract natural resources, reduces air pollution, and eases the strain on our water resources. Buildings account for about 40% of all energy use in the United States. EarthCraft encourages the use of energy efficient systems to reduce this impact

Water Efficiency (WE)

Conserving our finite freshwater resources has become vitally important in both protecting our environment and helping sustain economic growth in our region. The use of certain strategies like water-efficient fixtures, water-efficient landscaping and irrigation, and reusing water on-site through rainwater or greywater systems can significantly reduce a resident's water consumption as well as their utility bills.

The Water Efficiency category emphasizes the efficient use of potable water indoors and outdoors. An EarthCraft project aims to reduce water waste and stormwater run-off. Strategies include drought adapted landscaping, improved plumbing distributions systems and efficient plumbing fixtures.

Education and Operations (EO)

The best designed and constructed building can still be inefficient if the resident does not utilize its high-performance benefits properly. A study of EarthCraft certified multifamily housing in Virginia showed a 15% difference in energy usage when residents were educated on the operation of their apartment vs when they were not. The Education and Operations category provides strategies for informing residents of the benefits of an EarthCraft house as well as how to best use energy efficient features to maximize efficiency. Improved occupant education may lead to fewer comfort complaints and call backs in green projects.

Incorporating high performance measures and green construction technologies requires the review of all operations, not just construction practices, for evaluation of sustainability. The builders that integrate green business strategies into their entire company operations may have the greatest success in market transformation.

Although the EarthCraft program's main goal is to reduce the environmental impact of the buildings certified under the program, the program has an additional goal of encouraging EarthCraft Builders to minimize the negative environmental impacts of all of their projects. For example, EarthCraft Builders can earn points in the Operations and Management category by providing environmental checklists to all subcontractors.

Innovation (IN)

EarthCraft strives to advance market transformation towards green and high-performance building construction in the Southeast. While the program is comprehensive in scope, new products, technologies and strategies are continuing to be developed supporting the mission of EarthCraft and EarthCraft Builders. The Innovation category is intended to provide builders the opportunity to present new ideas for advancing green building and reward those implementing cutting-edge technologies. Builders are encouraged to present products, technologies, and strategies not covered elsewhere within the EarthCraft program.

Disclaimer and Notices

Viridiant provides the EarthCraft Multifamily V6.5 Technical Guidelines for your individual use and to copy as-is, or in part as needed. No content may be altered. In exchange for this authorization, you agree to retain all copyright and other proprietary notices contained in the Technical Guidelines. You also agree not to sell or modify the Technical Guidelines.

Also, please note that none of the parties involved in the funding or creation of the Technical Guidelines, including Southface, Viridiant, the Greater Atlanta Home Builders Association and all associated members, make any warranty (express or implied) or assume any liability or responsibility, to you or any third parties for the accuracy, completeness, or use of, or reliance on, any information contained in the Technical Guidelines, or for any injuries, losses or damages (including, without limitation, equitable relief) arising out of such use or reliance.

As a condition of use, you covenant not to sue, and agree to waive and release EarthCraft, Southface, Viridiant, the Greater Atlanta Home Builders Association and all associated members from any and all claims, demands and causes of action for any injuries, losses or damages (including, without limitation, equitable relief) that you may now or hereafter have a right to assert against such parties as a result of your use of, or reliance on, the Technical Guidelines.

Please note that the builder, architect, or primary project manager is solely responsible for choosing the EarthCraft Multifamily criteria that are appropriate for the project and for their proper installation. EarthCraft and its representatives are responsible only for verifying the completion of EarthCraft requirements as set forth in the Technical Guidelines; such verification in no way constitutes a warranty as to the appropriateness of the selected EarthCraft criteria or the quality of implementation.

Acknowledgements





EarthCraft would like to thank the support of our many government, industry and private sponsors and partners that help with the development and continued refinement of the EarthCraft Technical Guidelines:

- U.S. Department of Energy
- U.S. Environmental Protection Agency
- Georgia Environmental Facilities Authority
- EarthCraft Sponsors
- EarthCraft Technical Committee Members
- EarthCraft Technical Advisors
- EarthCraft Builders
- The countless other individuals that have provided feedback and shared information with EarthCraft.

For a current list of EarthCraft Sponsors, EarthCraft Technical Advisors, and EarthCraft Builders, please visit: www.viridiant.org.

If you would like to offer recommendations for refinement or improvement, please send comments to admin@viridiant.org.

EarthCraft Contact Information

	Website	www.viridiant.org
	Email	admin@viridiant.org
	General inquiries:	804.225.9843
	Fax	804.562.4159
	Mailing Address	1431 West Main Street Richmond, VA 23220

Site Planning (SP)

Site Selection (SP 1)

SP 1.0 Type of site

Criteria

1. *Brownfield site*

Build project on a brownfield site. A brownfield site is where expansion or re-development is complicated by the real or perceived presence of a hazardous substance, pollutant or contaminant. Brownfield sites are typically located at abandoned, idle or under-used industrial or commercial facilities.

2. *Previously developed site*

Build project on lot with preexisting paving or construction on $\geq 75\%$ of site.

3. *Infill development site*

Build project on lot that is served by existing public sewer infrastructure and ensure that 50% or 75% of lot boundary is adjacent to parcels of land previously developed for ≥ 5 years' time. Natural areas or corridors are not considered previously developed. If the property borders a road, the land use on the opposite side of the road from the property should be used.

Additional Resources

Technical assistance for building on brownfield sites may be obtained by contacting the Environmental Protection Agency's (EPA) Division of Waste Management: epa.gov/brownfields | epa.gov/brownfields (Permalink)

or

The Virginia Department of Environmental Quality: [Virginia DEQ Brownfields](http://VirginiaDEQ.org/Brownfields) | [Virginia Department of Environmental Quality](http://VirginiaDEQ.org) (Permalink)

Confirmation

- Brownfield site: the project team must show the property is listed on a state voluntary cleanup site and must provide the phase II site assessment (or greater) results if requested by the EarthCraft Technical Advisor.
- Previously developed and/or infill site: the project team must provide site plans showing compliance with the criteria listed above.
- The EarthCraft Technical Advisor will visually confirm criteria compliance at the EarthCraft Kickoff meeting.

SP 1.1 Dwelling units per acre

Criteria

Achieve dwelling unit per acre calculation of ≥ 15 dwelling units/acre, ≥ 20 dwelling units/acre, or ≥ 25 dwelling units/acre. This calculation will include all buildable land area within the project boundary, but may exclude permanently protected greenspace, floodplains, or tree-save areas. The acreage will be gross density of site including all parking lots, sidewalks, and other hardscape areas.

Example

One hundred dwelling units on a 5-acre lot with 1-acre preserved as a permanently protected tree save area. $100 \text{ units} / (5 \text{ acres} - 1 \text{ acre tree save}) = 25 \text{ dwelling units per acre}$.

Confirmation

- The project team must submit documentation demonstrating compliance to the EarthCraft Technical Advisor at the pre-drywall inspection.
- The EarthCraft Technical Advisor will review documentation provided by the builder at the pre-drywall inspection.

SP 2.0 Connectivity

Criteria

1. Walking distance to bus line ($\leq 1/2$ mile)

A. Existing: Demonstrate that the main entrance of at least one residential building is within 1/2 mile of an existing bus line. Measure distance by following a walkable route comprised of sidewalks, public trails and pedestrian crosswalks.

B. Planned: If there is no current bus access within 1/2 mile of the main entrance of at least one residential building, provide an adopted plan by a local or regional authority for bus line expansion and illustrate walkable routes consisting of sidewalks, public trails, and pedestrian crosswalks leading to the bus line should expansion occur.

2. Walking distance to rail/rapid transit ($\leq 1/2$ mile)

A. Existing: Demonstrate that the main entrance of at least one residential building is within 1/2 mile of an existing light rail/heavy rail rapid transit station. Measure distance by following a walkable route composed of sidewalks, public trails and pedestrian crosswalks.

B. Planned: If there is no current light rail/heavy rail rapid transit access within 1/2 mile of the main entrance of at least one residential building, provide an adopted plan by a local or regional authority for rail expansion and illustrate walkable routes comprised of sidewalks, public trails, and pedestrian crosswalks leading to the rail should expansion occur.

3. Biking distance to bike path ($\leq 1/2$ mile)

A. Existing: Demonstrate that the main entrance of at least one residential building is within 1/2 mile of an existing or new bike path. Measure distance by following bikeable route.

B. Planned: If there is no current bike path access within 1/2 mile of the main entrance of at least one residential building, provide an adopted plan by a local or regional authority for bike path expansion and illustrate walkable routes comprised of sidewalks, public trails, and pedestrian crosswalks leading to the bike path should expansion occur.

4. Walking distance to public open space or greenspace $\geq 3/4$ acre in size ($\leq 1/2$ mile)

A. Existing: Demonstrate that the main entrance of at least one residential building is within 1/2 mile of a park that is available for resident use and greater than 3/4 acre in size. Measure distance by following a walkable route comprised of sidewalks, public trails and pedestrian crosswalks. Two smaller parks equivalent in size to one large, 3/4 acre park, are accepted as meeting the intent.

B. Planned: If there is no current access to public open space or greenspace within 1/2 mile of the main entrance of at least one residential building, provide an adopted plan by a local or regional authority for increasing connectivity to these spaces and illustrate walkable routes comprised of sidewalks, public trails, and pedestrian crosswalks leading to open space or greenspace should expansion occur.

5. A & B: Walking distance to business district with 4/6 or more mixed uses ($\leq 1/2$ mile)

Demonstrate that the main entrance of at least one residential building is within 1/2 mile of an existing business district. Measure distance by following walkable route comprised of sidewalks and pedestrian crosswalks. Business district must have at least

4/6 or more distinct community resources (e.g., one library, one school, one grocery store and one restaurant). Businesses that primarily serve customers travelling by car (e.g., car wash or auto mechanic) will not count towards this.

Confirmation

- The builder must present documentation demonstrating compliance of criteria to the EarthCraft Technical Advisor at the pre-drywall inspection.
- The EarthCraft Technical Advisor will review documentation provided by the builder for compliance of criteria.

SP 2.1 Shade \geq 50% of hardscapes within 30' of building

Criteria

To reduce local heat island effects, shade at least 50% of hardscapes (paved area including walkways, parking lots, patios and tennis courts) within 30' of the building. Shaded area should be calculated based on tree canopy coverage when the sun is directly overhead based on 5 years growth. Public walkways and roads should not be included in the hardscape calculation.

Clarifications

Sites that provide 40% shade of hardscapes at completion (excludes 5 yr. growth period) also qualify.

Calculation must be based on 12 noon on the summer solstice.

It is required to install plants that maintain \geq 2' clearance from buildings at maturity.

Confirmation

- Project team will submit design and calculations indicating compliance with criteria above. Shade calculations will be required. The EarthCraft Technical Advisor will visually confirm compliance of criteria at final inspection.

SP 2.2 Reduce light pollution – all exterior lights full cutoff

Criteria

Full cutoff - Zero intensity at or above horizontal (90° above nadir) and limited to a value not exceeding 10% of lamp lumens at or above 80°"

Reduce light pollution by minimizing light trespass on site for the purpose of reducing sky-glow, increasing nighttime visibility and minimizing negative effects on nocturnal environments and human health and functioning.

Clarifications

100% of exterior lighting must comply.

Additional Resources

- [Illuminating Engineers Society](#)
- [What are the IESNA Cutoff Classifications?](#)

Confirmation

- Submittal information provided to Technical Advisor
- The EarthCraft Technical Advisor will visually confirm compliance of criteria at final inspection.

SP 2.3 Permanent stormwater control

Criteria

Control disturbed site area by integrating Low Impact Development Best Management Practices (LID BMP) into the project. All BMPs should be properly located to drain away from building foundation to protect building from moisture damage.

1. Direct impervious surface runoff to appropriately sized rain gardens, swales, drywells or bioretention areas. Receiving area soils should be amended to increase infiltration to the level required for maintaining stormwater. Keep the area protected from heavy machinery and parking during construction or mitigate soil compaction post construction.
2. Design and install rooftop gardens and green roofs.
3. Direct roof or site runoff into rain barrels and cisterns. Size barrels and cisterns appropriately and enable use of water for building reuse or landscape irrigation.

Use the LID manual for designing rain gardens, swales or bioretention areas (if applicable to the project). Provide the permanent stormwater management plan to scale clearly indicating: area of disturbed site, permeable and impermeable surfaces, and type and location of LID BMPs used. This plan can be integrated into the site plan, landscape plan or erosion control plan. The bioretention areas should be sized per the Virginia Runoff Reduction Method (VRRM) or another equivalent methodology approved by the State Water Control Board for water quality compliance with Part II B (9VAC25-870-65).

A. ≥25% of onsite impervious surface areas

Projects must disconnect at least 25% of onsite impervious surface areas from storm drains by implementing some or all of the LID BMPs from the list above.

B. ≥50% of onsite impervious surface areas

Projects must disconnect at least 50% of onsite impervious surface areas from storm drains by implementing some or all of the LID BMPs from the list above.

C. ≥75% of onsite impervious surface areas

Projects must disconnect at least 75% of onsite impervious surface areas from storm drains by implementing some or all of the LID BMPs from the list above.

Clarifications

Landscape installation plan must be consistent with the LID BMPs selected for the project. Alternative LID BMPs may be approved by EarthCraft prior to use.

Example

1,100 sq ft roof

150 sq ft pervious driveway

1,100 sq ft impervious surface total

530 sq ft of the roof drains to rain barrels sized appropriately

300 sq ft of the roof drains into a downspout and into a rain garden

In total, 880 sq ft (80%) of the 1,100 sq ft of impervious surface area drains to a LID BMP.

Additional Resources:

- [Virginia Runoff Reduction Method - Virginia Tech](#)
- [Virginia Stormwater Management Handbook - VA DEQ](#) | [Virginia Stormwater Management Handbook - VA DEQ](#) (Permalink)
- [Low Impact Development \(LID\) Urban Design Tools](#)
- [Water Smart Cities - NRDC](#)

Confirmation

- The project team must present documentation demonstrating compliance of criteria to the EarthCraft Technical Advisor at the pre-drywall inspection.
- The EarthCraft Project Manager will review documentation provided by the team for compliance of criteria
- The Technical Advisor will visually confirm compliance of criteria at pre-drywall inspection.

SP 2.4 Street trees are \leq 40' on center at minimum

Criteria

Plant or preserve shade trees at an average interval of \leq 40 feet along 75% of new or existing streets internal to and immediately adjacent to the project boundary. Trees should be planted on both sides of internal streets and on the project side of adjacent streets.

Confirmation

- The project team must present documentation demonstrating compliance with criteria above from the project's landscape designer clearly indicating tree wells or strip dimensions, tree specifications, and street lengths.
- The EarthCraft Technical Advisor will review documentation provided by the project team for compliance with criteria and visually confirm compliance with criteria at final inspections.

SP 2.5 Connectivity to adjacent sites:

Criteria

Promote multiple road connections off-site to improve vehicular ingress and egress and improve pedestrian connections to adjacent sites.

No street or pedestrian networks can be gated.

1. Improved vehicular access (2+ connections)

The project must provide \geq 2 connections to the off-site road network. The vehicular access points must include sidewalk accommodations.

2. Dedicated pedestrian and bike access

Provide a non-vehicular pathway along the edge of the project's boundary adjacent to developed parcels and undeveloped parcels. Pedestrian and bicycle access to future phases of the same development do not qualify. However, plans to provide access in future phases to adjacent parcels will qualify.

Connections are not required where existing buildings, bodies of water, critical slope areas or other natural areas designated for preservation prohibit through streets.

Confirmation

- The project team must present documentation showing the locations of connections in compliance with criteria.
- The EarthCraft Technical Advisor will review documentation provided by the project team for compliance with criteria and visually confirm compliance with criteria at final inspections.

SP 2.6 Community gardens

Criteria

Promote open space and the production of locally grown, community-maintained vegetation through community gardening areas. Community gardens provide a catalyst for community development while offering multiple benefits to the environment.

1. A fenced community garden will provide a minimum planting area equal to the mean size of all residential units.
2. The gardens must be a permanent fixture with storage areas provided for garden tools and products.
3. Post signs dictating rules and safety guidelines at garden entrance.
4. Provide a water source nearby for watering the garden. The water source should take into consideration best practices for water conservation. Rain barrels may be used, but not as the primary source of water.
5. The soil must be properly prepared for planting.
6. Gardens shall be surrounded on all sides with a minimum 4' high fence of weatherproof construction to discourage small children and animals from entering the garden. If pressurized wood is used for fencing or raised beds, ensure the manufacturer verifies that it is safe to grow edible plants in soil surrounded by their wood product.
7. The effects of any contaminants discovered in the Phase I Environmental Assessment must be considered before choosing to build the garden.

Clarification

If the development has 3 unit types (1 bed is 750 square feet, 2 bed is 900 square feet, and 3 bed is 1200 square feet), determine the mean of the floor plans to determine the required square footage of the garden plot.

$$\frac{750+900+1200}{3(\text{unique unit types})} = 950 \text{ square feet required}$$

Confirmation

- The project team must present documentation showing the location and size of the community garden in compliance with the criteria above. The garden must also incorporate all requirements listed above.
- The EarthCraft Technical Advisor will review documentation provided by the project team for compliance with criteria and visually confirm compliance with criteria at final inspections.

SP 2.7 Outdoor Community gathering space

Criteria

Provide outdoor gathering space large enough to accommodate at least 5 people, for the purpose of building community and improving social ties. Gathering space should have adequate seating, lighting, and shade provided by either nearby trees or structures such as a pavilion.

Confirmation

- The EarthCraft Technical Advisor will visually confirm compliance with criteria at install

SP 2.8 Install plant species that serve as pollinators on site for regional wildlife and or local endangered species for minimum of 20% of plantings

Criteria

Minimum 20% of plantings installed are native plant species that serve as pollinators for regional animal and plant communities listed within the Virginia Native Plants provided by Virginia Department of Environmental Quality.

Additional Resources

- [Native Plants for Conservation, Restoration and Landscaping - Native Plant Finder](#)
- [Pollinator Plants in Northeast](#)

Confirmation

- The EarthCraft Technical Advisor will visually confirm compliance with criteria at install

SP 2.9 Parking reduced below local ordinance (1:1 ratio)

Criteria

Reduce the amount of parking below a 1:1 ratio and below local zoning ordinance requirements and/or provide no new parking on site.

Confirmation

- The project team presents documentation showing the local parking ordinance and the number of parking spaces on site, clearly showing the criteria above is achieved.
- The EarthCraft Technical Advisor will review documentation provided by the project team for compliance with criteria and visually confirm compliance with criteria at final inspections

Site Preparation and Preservation Measures (SP 3)

SP 3.0 Workshop on erosion and sediment control

Criteria

Site supervisor must attend and pass examination for either the “Responsible Land Disturber” or equivalent certification offered by the local Soil and Water Conservation Commission.

Site supervisor must inform all subcontractors of the Erosion and Sedimentation Control Plan.

Additional Resources

- [Virginia Department of Environmental Quality Responsible Land Disturber Certificate | Virginia Department of Environmental Quality Responsible Land Disturber Certificate](#) (Permalink)
- [Virginia Department of Environmental Quality Certificate Search](#)
- [ESC Minimum Standards Table | ESC Minimum Standards Table](#) (Permalink)

Confirmation

- The builder must present documentation demonstrating compliance of criteria to the EarthCraft Technical Advisor at or before slab inspection.
- The EarthCraft Technical Advisor will review documentation provided by the builder for compliance of criteria.

SP 3.1 Site assessment identifying all greenspace and tree-save potential

Criteria

Develop a site assessment plan (site plan, aerial photo, or sketch) that identifies all greenspace features such as wetlands, stream banks/riparian buffers, steep slopes (15% or greater) and existing trees of 3" caliper or greater. Analyze which areas can be saved via reorientation of building and staging of construction materials and activities.

Confirmation

- The project team must present documentation demonstrating compliance with criteria to the EarthCraft Technical Advisor at the pre-drywall inspection.
- The EarthCraft Technical Advisor will review documentation provided by the project team for compliance with criteria.

SP 3.2 Erosion and sedimentation control plan

Criteria

Create an Erosion and Sedimentation Control Plan consistent with state or local best management practices. Include all required BMP and tree-save practices within the site plan and on site. These E&S measures must be maintained throughout the construction process as required by the most stringent code requirements.

Include, at a minimum, the following measures:

- Perimeter fencing installed and maintained properly to control runoff and siltation.
- Storm sewer inlets protected with straw bales, compost socks, silt stacks or comparable measure.
- Erosion control blanket used on steep slopes. Steep slopes are defined as areas with a slope $\geq 15\%$ change in elevation.
- Stabilize all disturbed areas with temporary seeding, straw or wood mulch or permanent vegetation immediately after rough grading is completed if a delay in finished grade is expected.

- Protected excavated topsoil areas. Excavated topsoil should have properly installed perimeter silt fencing or equivalent and be protected from erosion by wind and rain using tarps, seeding, mulch, compost, or other suitable measures.

The prepared plan must consist of a project map with the following elements:

- A location sketch of the project and nearby major roadways, streams and other identifiable landmarks within 200’ of the project boundary.
- A location sketch of major, onsite topographic features, streams, existing soil types and vegetation located on the project site. Existing and proposed topographic contours greater than 2’ should be shown on the sketch.
- Location and extent of temporary and permanent erosion and sediment control measures including both vegetative and structural practices.

Erosion control measures and plan should be maintained by the on-site contractor and adjusted as necessary throughout all construction phases.

Resources

- [Virginia DEQ Erosion and Sediment Control Law and Regulations](#) | [Virginia DEQ Erosion and Sediment Control Law and Regulations](#) (Permalink)

Confirmation

- The builder must submit documentation demonstrating compliance of criteria to the EarthCraft Project Manager prior to Design Review Meeting.
- The EarthCraft Technical Advisor will review documentation provided by the builder for compliance of criteria and visually verify measures on site.

SP 3.3 Do not install invasive plants on site

Criteria

EarthCraft will not permit the installation of any plant species listed in the High or Medium categories of the Virginia Invasive Plant Species List or Category 1 or 2 of the EPPC invasive plant list, with the exception of Bermuda Grass.

Additional Resources

- [Virginia Invasive Species List](#)
- For state-specific resources on invasive plants see <https://www.invasivespeciesinfo.gov/us/virginia>
- For resources specific to the Southeast see: [SEPPC](#)

Confirmation

- The EarthCraft Technical Advisor will verbally and visually confirm compliance of criteria with the builder at the pre-drywall and final inspections.

SP 3.4 Comply with all federal, state, and local government erosion control and protection measures

Criteria

Project must meet all federal, state and local government erosion control and protection measures.

Additional Resources

- [Virginia DEQ Erosion and Sediment Control Law and Regulations](#) | [Virginia DEC Erosion and Sediment Control Law and Regulations](#) (Permalink)

Confirmation

- The EarthCraft Technical Advisor will visually confirm compliance of criteria at pre-drywall and final inspections.

SP 3.5 Phase I environmental testing and remediation plan

Criteria

Comply with all federal guidelines regarding Phase I environmental site assessments. If the phase I shows the need for soil or building abatement the team must show compliance with clean-up requirements through the Phase II assessment (or greater).

Confirmation

- The project team will provide a copy of Phase I assessment results as requested by the EarthCraft Technical Advisor. If additional phase assessments are conducted these may also be requested.

SP 3.6 On-call personnel designated for erosion control during rain events

Criteria

The project team must designate on-call personnel for the purpose of maintenance/repair of erosion control measures during rainfall events. The on-call personnel must possess an active Certified Land Disturber (RLD) certification from the appropriate state soil and water conservation regulatory body.

Confirmation

- The project team will identify the point person and provide a copy of the Responsible Land Disturber certification as requested by the EarthCraft Technical Advisor.

SP 3.7 Downstream water quality testing (if applicable)

Criteria

The project must comply with stormwater discharge limitations required by the Federal Clean Water Act. If applicable, the general contractor will submit an updated Nephelometric Turbidity Units (NTU) report to the EarthCraft Technical Advisor before, during, and after construction is complete.

Clarifications

An EC Technical Advisor may request turbidity tests at any time. If test records indicate levels exceeding what is locally allowable, project personnel and contractor are responsible for adjusting best management practices to meet established performance targets.

If turbidity tests exceed allowable levels for two consecutive storm events, the project will be required to host a mandatory meeting between site contractor, turbidity testing agency and project manager to determine necessary changes for compliance. Documentation of the meeting must be submitted to ECMF.

If turbidity tests exceed allowable levels for a third consecutive storm event, the project will be unable to certify as ECMF.

For allowable limits based on site acreage and stream types please review the NTU limits from your appropriate state authority.

Additional Resources

- [Virginia Stormwater Management Handbook - VA DEQ](#) | [Virginia Stormwater Management Handbook - VA DEQ](#) (Permalink)
- [Tools for Water Monitors](#) | [Tools for Water Monitors](#) (Permalink)

Confirmation

- The project team must present documentation demonstrating compliance with criteria to the EarthCraft Technical Advisor during the inspection phase.
- The EarthCraft Technical Advisor will review documentation provided by the project team for compliance with criteria.

SP 3.8 Label all storm drain or storm inlets to discourage dumping of pollutants

Criteria

Label each storm drain within the development to discourage contractors and tenants from dumping pollutants in storm drains.

Clarification

Storm drain marking involves labeling storm drain inlets with plaques, tiles, painted or pre-cast messages warning citizens not to dump pollutants into the drain. The messages are generally a simple phrase or graphic to remind those passing by that the storm drains connect to local water bodies and that dumping will pollute those waters.

Additional Resources

- [Chesapeake Bay Foundation - Storm Drain Stenciling](#)
- [Fairfax County Government - Storm Drain Educational and Labeling Projects](#)

Confirmation

- The EarthCraft Technical Advisor will visually verify for compliance during mid-construction and final inspections.

SP 3.9 Road/vehicle cleaning protocols posted and enforced

Criteria

Designate a tire and vehicle washing area during the construction phase of the project. Create protocols to enforce both vehicle and road cleaning processes.

Clarifications

The vehicle cleaning area will have a clean path to and will be located within 100 feet of the construction entrance. The area should consist of a 32 ft. x 12 ft. gravel bed atop permeable ground and should have adequate water access for washing purposes.

This area should be properly documented in the Erosion and Sedimentation plan, Site plan, and marked on site. Washing must be enforced.

The project team should create protocols for off-site road cleaning to remove sediment and debris carried from the construction site.

Additional Resources

- [Temporary Construction Entrance - DEQ](#) | [Temporary Construction Entrance - DEQ](#) (Permalink)

Confirmation

- The project's civil engineer or other professional will identify the location and requirements for the above criteria within the project's site plans.
- The EarthCraft Technical Advisor will visually confirm location of the wash out station during the EarthCraft Kick-Off meeting.

SP 3.10 Tree preservation and protection measures employed on site

Criteria

Use mature vegetation to create a sense of place, aid in mitigation of heat island effect and preserve natural landscape.

Preserve at least 25% of existing trees that have a chest-height (4 feet above the ground) diameter of 8 inches or more. The tree root zones of the selected trees must be protected with a physical barrier during all site clearing, grading and construction activities.

Create a Tree Preservation Plan that includes the following:

Tree Survey

- Consult with a certified arborist to assess the existing tree stock prior to establishing the building footprint.
- Determine which trees are in good health and have cultural, native, aesthetic and/or monetary significance.

Tree Protection

- Clearly indicate tree-save areas and protection measures in construction documents.
- Tree(s) must be fenced around the drip line throughout the construction process with tall, bright, protective fencing.
- Avoid soil being placed on top of any root zone for trees that are designated for preservation. Ensure the protected tree species' needs for growth, sunlight and water integrate well with the new building design.

Resources

- [Tree Preservation and Protection - VA DEQ](#) | [Tree Preservation and Protection - VA DEQ](#) (Permalink)
- [Virginia Department of Forestry Laws and Regulations](#)
- [North Carolina State University, Construction and Tree Protection](#)

Confirmation

- The project team will identify tree preservation potential and identify the trees to be saved within the project's site plans.
- The EarthCraft Technical Advisor will visually verify the tree protection measures are appropriately employed and provided for the identified trees. Confirmation will begin at the EarthCraft Kick-Off meeting and continue until project completion.

SP 3.11 Leave site undisturbed and protect greenspace (min 25%) from future development

Criteria

The site will permanently protect a minimum of 25% of buildable land area as permanent greenspace.

Clarifications

Buildable land area will exclude any areas that are protected through federal, local, or state requirements. Areas already required to be protected such as floodplains or specific project boundaries can only count towards the tree save percentage if the project team can develop permeable pathways to utilize the area as a community amenity.

Confirmation

- The project team must present documentation clearly identifying the percentage of greenspace protection complying with the criteria above.
- The EarthCraft Technical Advisor will visually verify the greenspace protection measures. Confirmation will begin at the EarthCraft Kick-Off meeting and continue until project completion.

SP 3.12 Mill cleared logs

Criteria

Commercially process 100% of logs that meet sawmill standards into lumber, pulp or other use.

Clarifications

Logs cannot be buried in a landfill or chipped.

Confirmation

- The project team must present documentation demonstrating compliance with criteria to the EarthCraft Technical Advisor at the pre-drywall inspection.
- The EarthCraft Technical Advisor will review documentation provided by the project team for compliance with criteria.

SP 3.13 Grind stumps and limbs for mulch

Criteria

Grind 80% or greater of all tree stumps and limbs for mulch to be used on site or in a neighboring development. Mulched material cannot be buried in a landfill or burned.

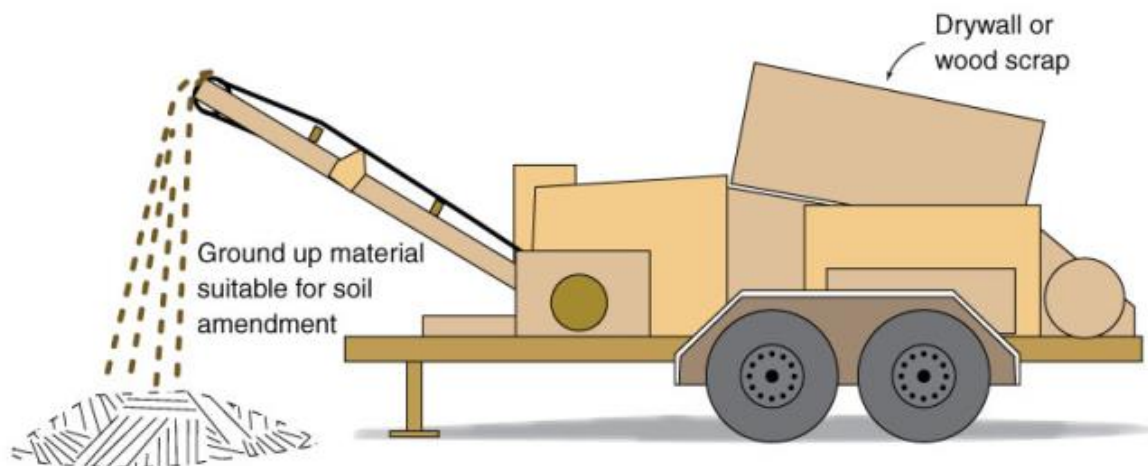

Figure 1: Waste grinder

Confirmation

- The EarthCraft Technical Advisor will visually confirm compliance with criteria at the EarthCraft Kick-Off Meeting.

SP 3.14 Tree planting (12 trees per acre; trees ≥ 2 " diameter)

Criteria

Plant a minimum of 12 trees per acre. All trees must be ≥ 2 " in diameter at breast height (DBH).

Confirmation

- The EarthCraft Technical Advisor will visually confirm compliance with criteria at final inspection.

Alternative Transportation Accommodations (SP 4)

SP 4.0 Bike Racks

Criteria

Provide bike racks for $\geq 10\%$ of dwelling units.

Confirmation

- The project team will identify bike rack location and capacity on site plan.
- The EarthCraft Technical Advisor will confirm at final inspection.

SP 4.1 Covered bike storage facility

Criteria

Provide Bike racks for $\geq 10\%$ of dwelling units in a covered and secure location.

Confirmation

- The project team will identify bike rack location and capacity on site plan.
- The EarthCraft Technical Advisor will confirm at final inspection.

SP 4.2 Tenant access to business center

Criteria

Provide community accessible meeting spaces for tenant use. Areas will have internet and phone capacity. Tenants will be allowed to sign up and use the meeting space in common areas for private business needs.

Confirmation

- The project team will include program in management guidelines and educate tenants upon move-in.
- The EarthCraft Technical Advisor will confirm at final inspection.

SP 4.3 Covered bus stop

Criteria

This development will provide a covered bus stop that meets the intent of the regularly scheduled bus service.

Confirmation

- The project team will identify bus stop on site plan.
- The EarthCraft Technical Advisor will confirm at final inspection.

SP 4.4 Electric Vehicle Charging Facility

Criteria

Provide priority parking and charging stations for electric vehicles. The number of charging stations must equal at least half the number of required ADA spaces and must be second in priority to those spaces.

Confirmation

- The project team will identify the charging facility locations and capacity on site plan.
- The EarthCraft Technical Advisor will confirm at final inspection.

Construction Waste Management (CW)

CW 1.0 No construction materials burned or buried on site

Criteria

No construction materials burned or buried on job site.

Confirmation

- The EarthCraft Technical Advisor will verbally and visually confirm compliance of criteria with the builder at the pre-drywall and final inspections.

CW 1.1 Only state-approved landfills may be utilized

Criteria

Only state-approved landfills may be utilized for waste disposal.

Confirmation

- The EarthCraft Technical Advisor will verbally confirm compliance of criteria with the builder at the pre-drywall and final inspections.

CW 1.2 Post waste management plan and divert $\geq 75\%$ from landfill

Criteria

Post a construction waste management plan on site, educate each subcontractor on the aspects of the plan that pertains to their work and enforce these measures. Waste management plan must either provide for onsite separation of materials to be recycled or provide for separation of recyclable materials by clean-up or waste hauling firms. Maintain documentation on diversion rate for each material. Diversion rate must be shown to span the entire length of construction on site.

1. Wood

Avoid disposal of 75% or greater (by weight or volume) of solid sawn wood by recycling through a state or county approved program or by on-site grinding and application of wood chips as mulch. Pressure treated wood is exempt from this requirement and may not be milled or applied as mulch.

2. Cardboard

Avoid disposal of a minimum of 75% (by weight or volume) of cardboard generated from construction, including all material packaging.

3. Metal (including beverage containers)

Avoid disposal of a minimum of 75% (by weight or volume) of metal generated from construction, including contractor beverage cans.

4. Drywall (recycle or grind and spread on site)

Avoid disposal of a minimum of 75% (by weight or volume) of drywall generated from construction through an approved recycling program, or by onsite grinding and application of drywall as a soil amendment.

5. Plastics (including beverage containers)

Avoid disposal of a minimum of 75% (by weight or volume) of plastic generated from construction, including contractor beverage containers.

6. Shingles

Avoid disposal of a minimum of 75% (by weight or volume) of shingles generated from construction. Recycled shingle scraps offer a variety of uses including gravel substitutes

for the wearing surface for rural roads, asphalt cement modifier and aggregate substitute and mineral filler for asphalt paving mixes.

Additional Resources

- [NAHB Research Center's "Builder's Field Guide to Residential Construction Waste Management"](#)

Confirmation

- The builder must present documentation demonstrating compliance of criteria to the EarthCraft Technical Advisor at the pre-drywall inspection and at project completion.
- The EarthCraft Technical Advisor will review documentation provided by the builder for compliance of criteria and will visually confirm compliance throughout construction.

CW 1.3 Central Cut Area

Criteria

Use a central cutting area and store wood end-cuts for reuse.

Clarifications

The central cut area may move around the job site as construction progresses to be easily accessible for the majority of framing contractors; however, only one cut area per section or floor of the building is permitted at any given time.

Definitions

A central cut area is defined as a central location where all lumber products are to be cut.

Confirmation

- Project team will provide documentation showing this is part of the framing scope.
- The EarthCraft Technical Advisor will visually confirm compliance with criteria.

CW 1.4 Previously developed site: divert \geq 25% of demolition waste from landfill

Criteria

At least 25% of the material from a development that has been deconstructed will be diverted from landfills either by reuse in the new project or by other diversion strategies.

Clarification

The calculation of material percentage should be based on the weight of the materials. If it is not practical to weigh the materials, approximate weights may be used. For example, if foundation waste will be diverted, an approximate weight per cubic foot may be determined to calculate the total weight of the foundation assembly.

Confirmation

- The project team must present documentation demonstrating compliance with criteria to the EarthCraft Technical Advisor at the EarthCraft Kick-Off Meeting.
- The EarthCraft Technical Advisor will review documentation provided by the project team for compliance with criteria.

Resource Efficiency (RE)

Resource Efficient Design (RE 1)

RE 1.0 Limit framing at all windows and doors

Criteria

Limit framing at windows to a maximum of one pair of king studs and one pair of jack studs per window opening to support the header and windowsill. Additional jack studs shall be used only as needed for structural support and cripple studs only as needed to maintain on-center spacing of studs.

Clarifications

The builder must present construction documents demonstrating structural requirements for excess framing, such as additional jack studs or excess cripple studs.

Confirmation

- The EarthCraft Technical Advisor will visually confirm compliance of criteria at pre-drywall inspection.

RE 1.1 Engineered roof framing ($\geq 90\%$)

Criteria

Construct 90% of roof framing using non-dimensional (engineered) structural wood, such as engineered trusses, prefabricated I-beams or non-wood material, such as steel. All engineered wood products must have no added urea-formaldehyde.

Per Required Item BE 3.7 - If constructing a steel truss ceiling or steel joist ceiling, the entire exterior surface of the studs must be covered with a minimum of R-7.5 insulated sheathing.

Confirmation

- The EarthCraft Technical Advisor will visually confirm compliance with criteria at pre-drywall inspection.

RE 1.2 Advanced Framing

Criteria

1. *2-stud corners at all locations where structurally feasible*

Use advanced framing techniques to frame the intersecting corner of two walls to reduce framing and provide continuous insulation (corners with more than two studs are not permitted) where structurally feasible.

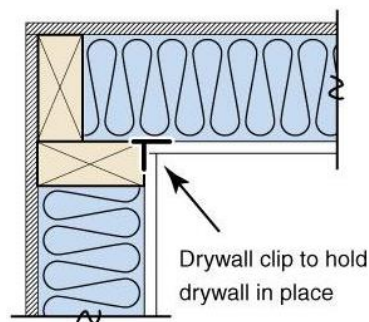

Figure 2: 2-stud corner

2. Ladder T-walls at all locations where structurally feasible

Construct exterior/interior wall intersections to reduce framing members and provide continuous insulation where structurally feasible.

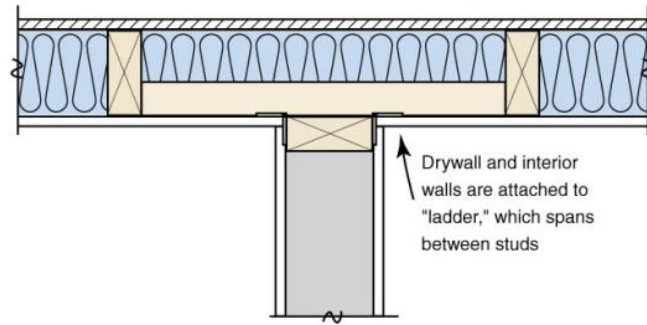

Figure 3: Ladder T-wall

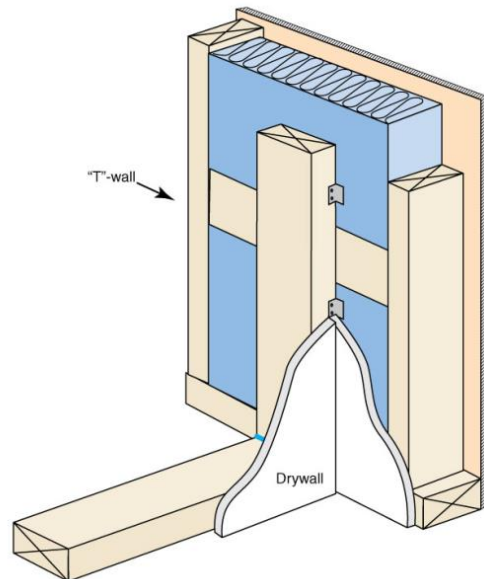

Figure 4: Ladder T-wall

3. Size headers for loads (non-structural headers in non-load bearing walls)

Design and install appropriately sized headers in all walls where structurally feasible. Eliminate load bearing headers in all non-load bearing walls and do not size all headers in load bearing walls to accommodate the greatest load case.

Clarifications

Consult local building codes in areas susceptible to high wind or seismic regions.

If installing a ladder T-wall, begin first ladder 2' above the subfloor to aid in the installation of drywall.

Confirmation

- The EarthCraft Technical Advisor will visually confirm compliance of criteria at pre-drywall inspection.

RE 1.3 Average floor area of unit

Criteria

A. < 800 sq ft

The average conditioned floor area of all units is less than 800 sq ft.

B. 800-1,100 sq ft

The average conditioned floor area of all units is between 800 and 1,100 sq ft.

Clarifications

The average floor area must be derived from the areas specified by the conditioned floor areas in the unit schedule.

Confirmation

- The project team must present documentation demonstrating compliance with criteria to the EarthCraft Technical Advisor.
- The EarthCraft Technical Advisor will review documentation provided by the project team for compliance with criteria and will visually confirm compliance with criteria at pre-drywall and final inspections.

RE 1.4 Floor joists are 24” on center (≥80%)

Criteria

Space at least 80% of all floor joists at 24” on center to minimize material waste.

Confirmation

- The EarthCraft Technical Advisor will visually confirm at pre-drywall inspection.

RE 1.5 Non-load bearing wall studs are 24” on center

Criteria

Space all non-load bearing wall studs at 24” on center.

Clarifications

The project team must present construction documents demonstrating structural requirements for excess framing greater than 5%.

Example

Assuming 24” stud spacing, no more than one vertical stud (lacking a structural purpose) for every 30 linear feet of wall would be permitted.

Confirmation

- The EarthCraft Technical Advisor will visually confirm compliance with criteria at pre-drywall inspection.

Advanced Framing Products (RE 2)

RE 2.0 Precast insulated foundation walls (≥90%)

Criteria

Construct a minimum of 90% of foundation walls using insulated precast concrete foundation walls. Foundation wall insulation must meet the prescriptive requirements for basement or mass walls as applicable in the 2018 IECC. Install walls according to manufacturer specifications.

Confirmation

- The EarthCraft Technical Advisor will visually confirm compliance of criteria at pre-drywall inspection.

RE 2.1 Insulated concrete forms or precast autoclaved aerated concrete (≥90%)

Criteria

1. Foundation walls

Construct a minimum of 90% of foundation walls using either insulated concrete forms (ICF) or precast autoclaved aerated concrete (AAC). Install ICF walls according to manufacturer's specification, to a minimum of R-17 insulation, and meet state termite protection guidelines for ground contact insulation. Install AAC walls according to manufacturer's specifications and meet the prescriptive requirements for basement or mass walls as applicable in the 2018 IECC.

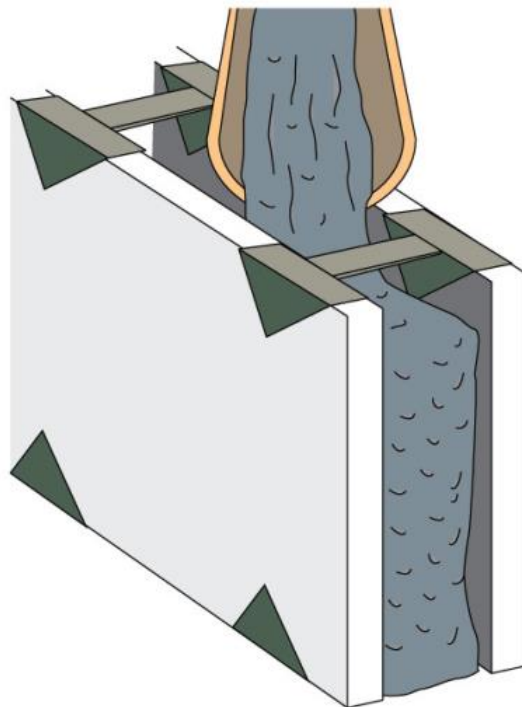

Figure 5: Insulated concrete form (ICF)

2. Exterior Walls

Construct a minimum of 90% of exterior walls using either insulated concrete forms (ICF) or precast autoclaved aerated concrete (AAC). Install ICF walls according to manufacturer's specification, to a minimum of R-17 insulation, and meet state termite protection guidelines for ground contact insulation. Install AAC walls according to manufacturer's specifications and meet the prescriptive requirements for mass walls as applicable in the 2009 IECC.

Confirmation

- The EarthCraft Technical Advisor will visually confirm compliance of criteria at pre-drywall inspection.

RE 2.2 Engineered wall framing (≥90%)

Criteria

Construct a minimum of 90% of total wall framing using non-solid sawn wood, such as laminated wood (e.g., laminated strand lumber) or finger-jointed studs.

Clarifications

Steel studs are not eligible for meeting this criterion. All non-solid sawn wood products must have no added urea-formaldehyde.

Confirmation

- The EarthCraft Technical Advisor will visually confirm compliance of criteria at pre-drywall inspection.

RE 2.3 Deliver panelized construction or SIPs to the site pre-framed (≥90%)

Criteria

1. Floors

Construct a minimum of 90% of the floor area using a panelized floor system (e.g., structurally insulated panels) delivered to the jobsite pre-framed and pre-cut. If installing structurally insulated panels (SIPs), a minimum of R-19 insulation must be used in Climate Zone 4, demonstrating code compliance for trade-offs where appropriate. In all cases, install panelized floor according to manufacturer specifications.

2. Exterior walls

Construct a minimum of 90% of all exterior walls using panelized wall systems (e.g., structurally insulated panels) delivered to the jobsite pre-framed and pre-cut. If installing structurally insulated panels (SIPs), a minimum of R-13 insulation must be used. In all cases, install panelized walls according to manufacturer specifications.

3. Roof

Construct a minimum of 90% of the roof area using a panelized roof system (e.g., structurally insulated panels) delivered to the jobsite pre-framed and pre-cut. If installing structurally insulated panels (SIPs), a minimum of R-19 insulation must be used in Climate Zone 4, demonstrating code compliance for trade-offs where appropriate. In all cases, install panelized roof according to manufacturer specifications.

4. Modular construction

Construct above grade sections off site and deliver in modules to the site.

Clarifications

Thermal mass and infiltration effects may not be included in R-value.

Floor area must equal conditioned floor area used for the confirmed HERS energy model.

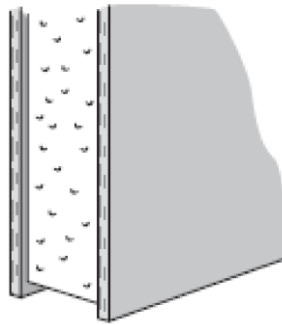

Figure 6: Structural insulated panel (SIP)

Confirmation

- The EarthCraft Technical Advisor will visually confirm compliance of criteria at pre-drywall inspection.

RE 2.4 Structural headers are steel or engineered wood ($\geq 90\%$)

Criteria

A minimum of 90% of the total headers must be manufactured from non-solid sawn wood, such as laminated wood (e.g., laminated veneer lumber (LVL), laminated strand lumber (LSL)), prefabricated insulated I-joist or steel beams. All non-solid sawn wood products must have no added urea-formaldehyde.

Confirmation

- The EarthCraft Technical Advisor will visually confirm compliance of criteria at pre-drywall inspection.

Local, Recycled and/or Natural Content Materials (RE 3)

RE 3.0 Use recycled concrete or alternate material as aggregate in foundation

Criteria

At least 30% of coarse aggregate or 10% of fine aggregate in poured concrete structures must be from demolished concrete or alternative material (e.g., crushed porcelain).

Confirmation

- The builder must present documentation demonstrating compliance of criteria to the EarthCraft Technical Advisor at the pre-drywall inspection.
- The EarthCraft Technical Advisor will review documentation provided by the builder for compliance of criteria.

RE 3.1 Replace $\geq 25\%$ of cement in concrete with fly ash or slag

Criteria

1. Slab and/or foundation walls

Replace $\geq 25\%$ of the cement with fly ash or slag in all concrete used for footings, foundation and basement walls and slabs.

2. Exterior cladding and trim

Replace $\geq 25\%$ of the cement with fly ash or slag in all concrete used for $\geq 75\%$ exterior cladding and trim.

Confirmation

- The builder must present documentation demonstrating compliance of criteria to the EarthCraft Technical Advisor at the pre-drywall inspection.
- The EarthCraft Technical Advisor will review documentation provided by the builder for compliance of criteria.

RE 3.2 Lumber/millwork/flooring: FSC tropical wood (100%) or use no tropical wood

Criteria

Use no tropical wood in project, including all lumber, millwork, and flooring, if tropical wood is used, 100% must be FSC certified to maintain points.

Confirmation

- The builder must present documentation demonstrating compliance of criteria to the EarthCraft Technical Advisor at the pre-drywall inspection.
- The EarthCraft Technical Advisor will review documentation provided by the builder for compliance of criteria.

RE 3.3 Use building materials extracted, processed, and manufactured ≤ 500 miles from site

Criteria

Use building materials that 90% by weight or volume have been extracted, processed, and manufactured within 500 miles of the site.

Each product meeting the criteria earns 1 point; no more than five products may receive credit for these points.

Confirmation

- The project team must submit documentation demonstrating compliance with the criteria above. This can come in the form of product literature or official correspondence with a representative of the material manufacturer.

RE 3.4 Reused, recycled, MDF with no added urea-formaldehyde, local species or FSC certified wood

Criteria

1. *Cabinet faces*

Install cabinet faces either made from reclaimed wood, Medium Density Fiberboard (MDF) with no added urea-formaldehyde, FSC certified wood or other durable natural material from a local source (≤500 miles from site) such as wood. Reused cabinet faces and cabinet faces made of ≥25% recycled content also qualify.

2. *Countertops*

Install countertops made from reclaimed wood, FSC certified wood or other durable natural material from a local source (≤500 miles from site) such as stone. Reused countertops and countertops made of ≥25% recycled content also qualify.

Clarifications

Install only structural plywood and OSB certified compliant with PS1 or PS2 and made with moisture-resistant adhesives as indicated by “Exposure 1” or “Exterior” on the [American Plywood Association \(APA\) trademark](#).

Install only hardwood plywood certified compliant with the formaldehyde emissions requirements of ANSI/HPVA HP-1-2016 and U.S. HUD Title 24, Part 3280, or certified compliant with CA Title 17.

Install only particleboard and MDF certified compliant with the formaldehyde emissions requirements of ANSI A208.1 and A208.2, respectively, and U.S. HUD Title 24, Part 3280, or certified compliant with EPPS CPA 3-08 by the CPA Grademark certification program, or certified compliant with CA Title 17.

Install only cabinetry made with component materials certified with the above requirements or registered brands or produced in registered plants certified under KCMA’s Environmental Stewardship Certification Program (ESP 01-06).

Confirmation

- The builder must present documentation demonstrating compliance of criteria to the EarthCraft Technical Advisor at the final inspection.
- The EarthCraft Technical Advisor will review documentation provided by the builder for compliance of criteria.

RE 3.5 Exterior cladding and trim (≥25% recycled content material on ≥75% area)

Criteria

Install ≥75% of exterior cladding and trim with ≥25% recycled content material (pre or post-consumer, excluding fly ash) content by weight or volume. Recycled content must be certified by Scientific Certification Systems (SCS).

Clarifications

Recycled fly ash may not be counted under this criterion, but rather under Point Item RE 3.1.

Additional Resources

- For more information about SCS-certified insulation see www.scscertified.com

- [Recycled Content Construction Products](#)

Confirmation

- The builder must present documentation demonstrating compliance of criteria to the EarthCraft Technical Advisor at the pre-drywall inspection.
- The EarthCraft Technical Advisor will review documentation provided by the builder for compliance of criteria.

RE 3.6 Insulation (≥25% recycled content material)

Criteria

Install 100% of insulation with ≥25% recycled material (pre or post-consumer) content by weight or volume in all walls, floors and ceilings.

Additional Resources

- For more information about SCS-certified insulation see www.scscertified.com
- [Recycled Content Construction Products](#)

Confirmation

- The builder must present documentation demonstrating compliance of criteria to the EarthCraft Technical Advisor at the pre-drywall inspection.
- The EarthCraft Technical Advisor will review documentation provided by the builder for compliance of criteria.

RE 3.7 Flooring

Criteria

1. *Cork, natural linoleum, sealed concrete, or bamboo flooring (≥20% of total floor area)*

Install cork, natural linoleum, sealed concrete or bamboo flooring on ≥20% of total floor area. Bamboo flooring must be sustainably harvested.

2. *Recycled content tiles (≥30% recycled content material on 100% of tile floor area)*

Install tile with ≥30% recycled content on 100% of tile floor area. Recycled content must be Scientific Certification Systems (SCS) certified.

3. *Carpet (≥50% recycled content material on ≥ 50% of all carpeted floor area)*

Install carpet with ≥50% recycled content (pre or post-consumer) on 50% of carpet floor area. Recycled content must be Scientific Certification Systems (SCS) certified.

4. *Biodegradable carpet and backing (≥50% of all carpeted floor area)*

Install carpet and backing that is constructed of organic materials (e.g., wool, hemp, etc.) that is readily biodegrade when exposed to moisture and sunlight on 50% of all carpeted floor area.

Clarifications

Floor area must equal conditioned floor area used for the confirmed HERS energy model.

Additional Resources

- For more information about SCS-certified products see www.scscertified.com.
- [Recycled Content Construction Products](#)

Confirmation

- The builder must present documentation demonstrating compliance of criteria to the EarthCraft Technical Advisor at the final inspection.
- The EarthCraft Technical Advisor will review documentation provided by the builder for compliance of criteria and will visually confirm compliance of criteria at final inspection.

RE 3.8 Engineered trim

Criteria

1. Interior (≥80%)

Construct a minimum of 80% of interior trim from non-solid sawn wood (e.g., finger-jointed wood, medium or high-density fiber board (MDF or HDF), etc.) or non-wood material, such as PVC. All non-solid sawn wood products must have no added urea-formaldehyde.

2. Exterior, including soffit, fascia, and trim (≥75%)

Construct a minimum of 75% of exterior trim (e.g., soffit, fascia and trim) from non-solid sawn wood (e.g., finger-jointed wood, cementitious fiberboard (MDF or HDF), etc.) or non-wood material, such as PVC. All non-solid sawn wood products must have no added urea-formaldehyde.

Confirmation

- The EarthCraft Technical Advisor will visually confirm compliance of criteria at final inspection.

RE 3.9 Roofing material (≥50% recycled content material on ≥90% area)

Criteria

Install roofing material with ≥50% recycled content materials on ≥90% of the entire roof area.

Confirmation

- The builder must present documentation demonstrating compliance of criteria to the EarthCraft Technical Advisor at the pre-drywall inspection.
- The EarthCraft Technical Advisor will review documentation provided by the builder for compliance of criteria.

Building Reuse (RE 4)

RE 4.0 Gut Rehab or Adaptive Reuse

Criteria

The project will qualify as gut rehabilitation if a substantial renovation occurs and includes exposure of the wall cavities (through removing interior walls or exterior cladding) to allow for confirmation of air sealing and insulation requirements.

The project will qualify as an adaptive reuse project if the building shell is repurposed from a non-residential use to a residential dwelling structure.

For any adaptive reuse project, the project design must follow the adaptive reuse priority list found in the EarthCraft Multifamily worksheet.

Confirmation

- The EarthCraft Technical Advisor and EarthCraft Project Manager can help clarify whether a building will qualify as Gut Rehab or Adaptive Reuse.

Durability and Moisture Management (DU)

Products and Applications (DU 1)

DU 1.0 All roof valleys direct water away from walls, dormers, chimneys, etc.

Criteria

Roof must be designed and built so that all roof valleys direct water flow away from walls, dormers, chimneys, or vertical surfaces of any kind.

Confirmation

- The EarthCraft Technical Advisor will visually confirm compliance of criteria at pre-drywall inspection.

DU 1.1 Install drainage plane per manufacturer's specifications

Criteria

A drainage plane must be installed and sealed as instructed by the manufacturer on the entire building assembly exposed to the exterior.

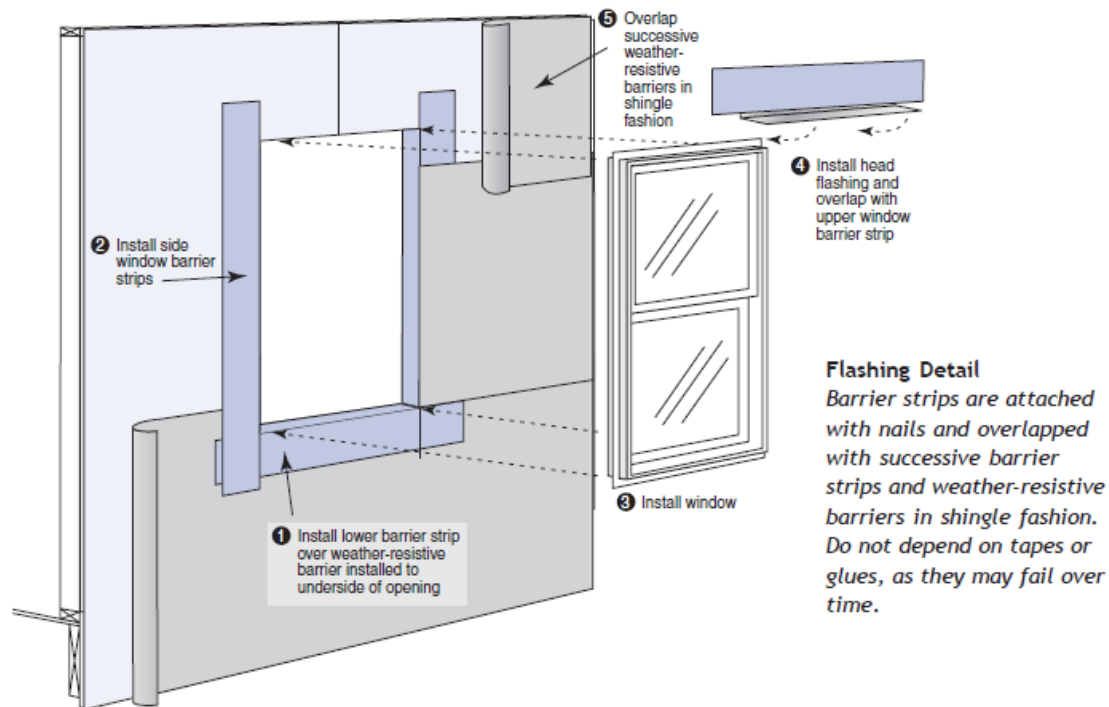

Figure 7: Example of manufacturer's specifications for drainage plane installation

Additional Resources

- [Moisture Control Guidance for Building Design, Construction, and Maintenance - EPA](#)

Confirmation

- The builder will illustrate compliance of criteria through photo documentation submitted to the EarthCraft Technical Advisor at pre-drywall.
- The EarthCraft Technical Advisor will review photo documentation provided by the builder for compliance of criteria.

DU 1.2 Integrate drainage plane

Criteria

1. Window and door pan flashing at sills and side flashing

Install water resistant flashing at the base and sides of all window and exterior door rough openings to direct water leaks out of the wall assembly. Side flashing must extend over sill flashing. All flashing must be integrated with drainage plane.

2. Window and door head/top flashing

Install water resistant flashing at the head of all windows and exterior doors. Flashing must extend a minimum of 6" above the top of the window or door, or per manufacturer's specifications. This head/top flashing must extend over side flashing and be integrated with drainage plane.

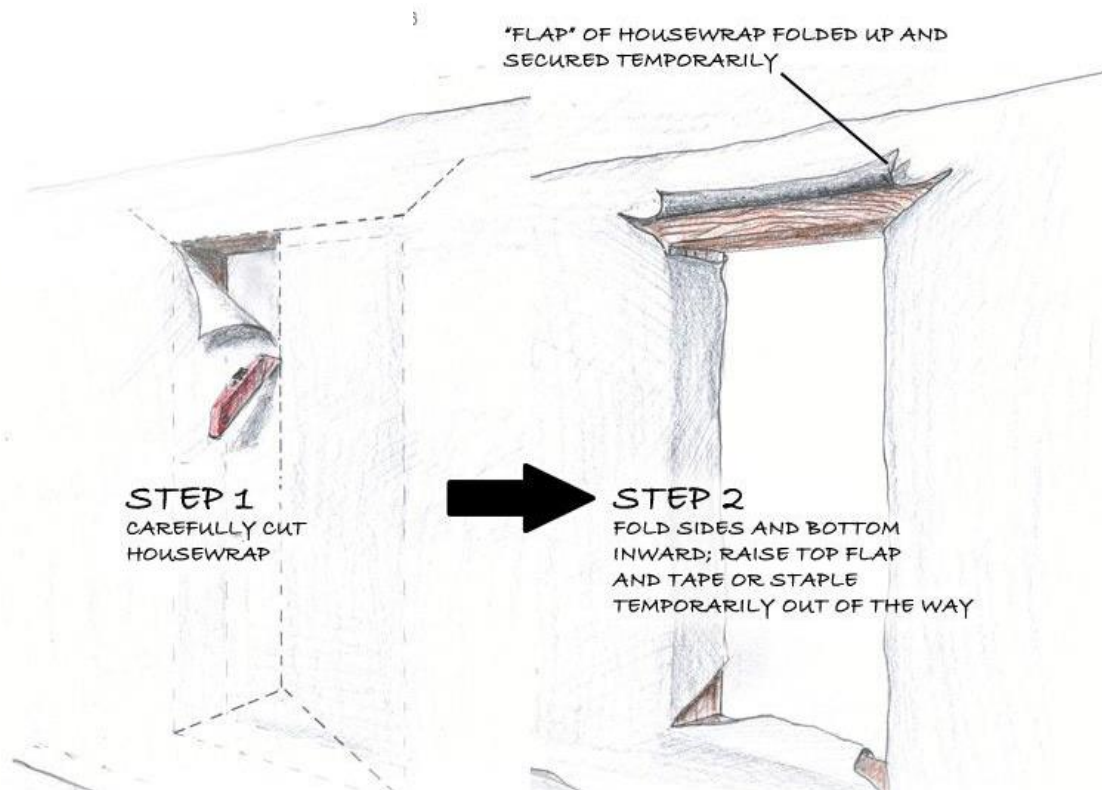

SOURCE: US EPA Indoor airPLUS

Figure 8: Steps 1 & 2: Preparing house wrap or builder paper

CREATE BACK-DAM OR SLOPE TO DIRECT ANY WATER THAT DRAINS TO THE SILL AREA OUTWARD AND ONTO THE DRAINAGE PLANE (HOUSEWRAP)

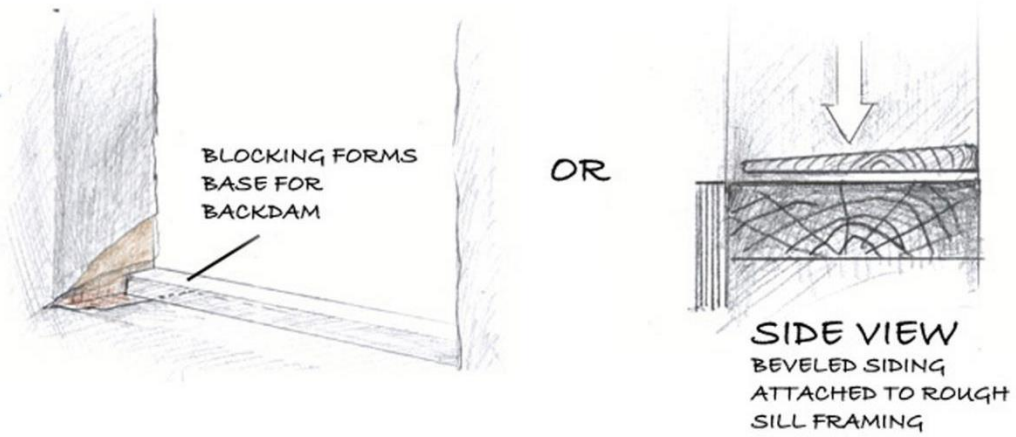

SOURCE: US EPA Indoor airPLUS

Figure 9: Step 3: Create back dam or slope away from interior

SELF-ADHESIVE MEMBRANE APPLIED TO SILL AREA, CREATING "PAN FLASHING" WHICH LAPS OVER AND ADHERES TO DRAINAGE PLANE

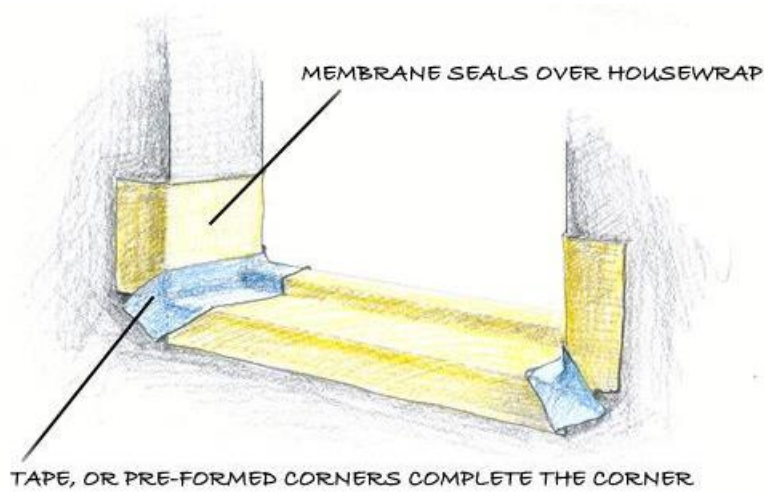

SOURCE: US EPA Indoor airPLUS

Figure 10: Step 4: Pan flashing - Option 1

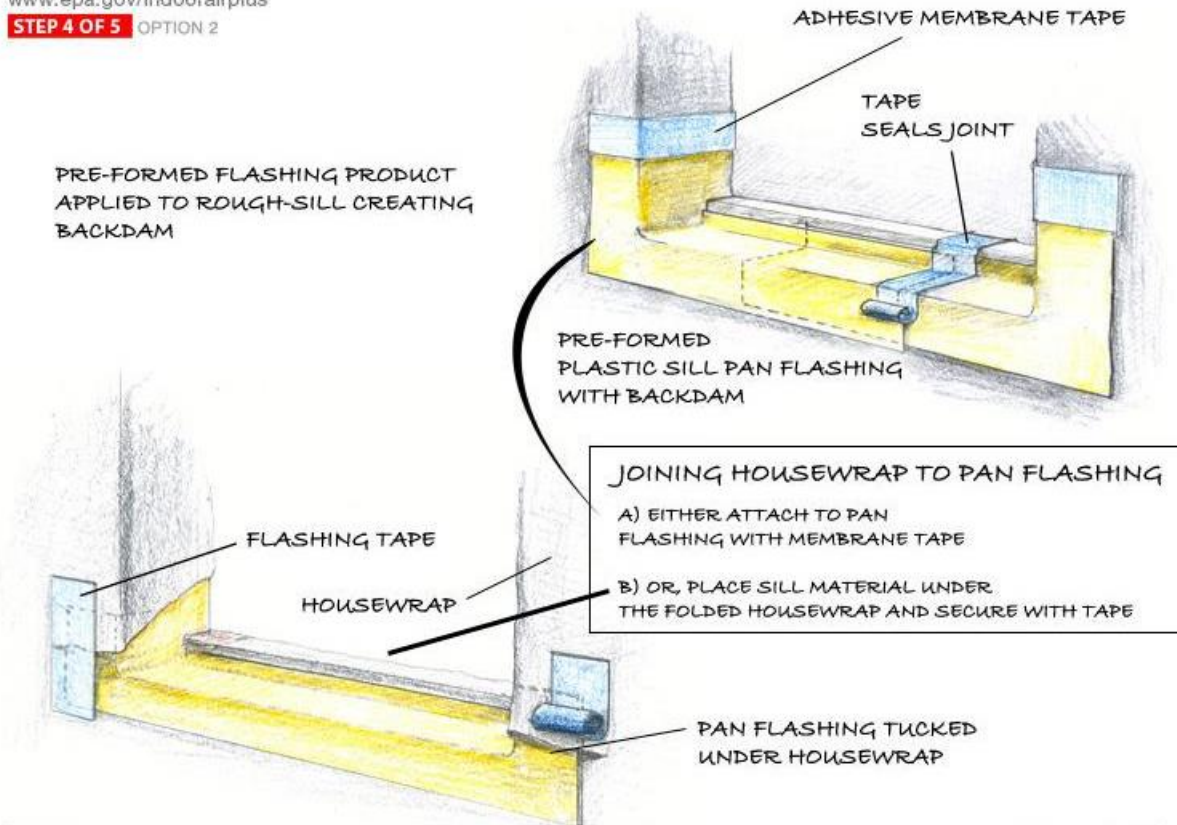

SOURCE: US EPA Indoor airPLUS

Figure 11: Step 4: Install plan flashing - Option 2

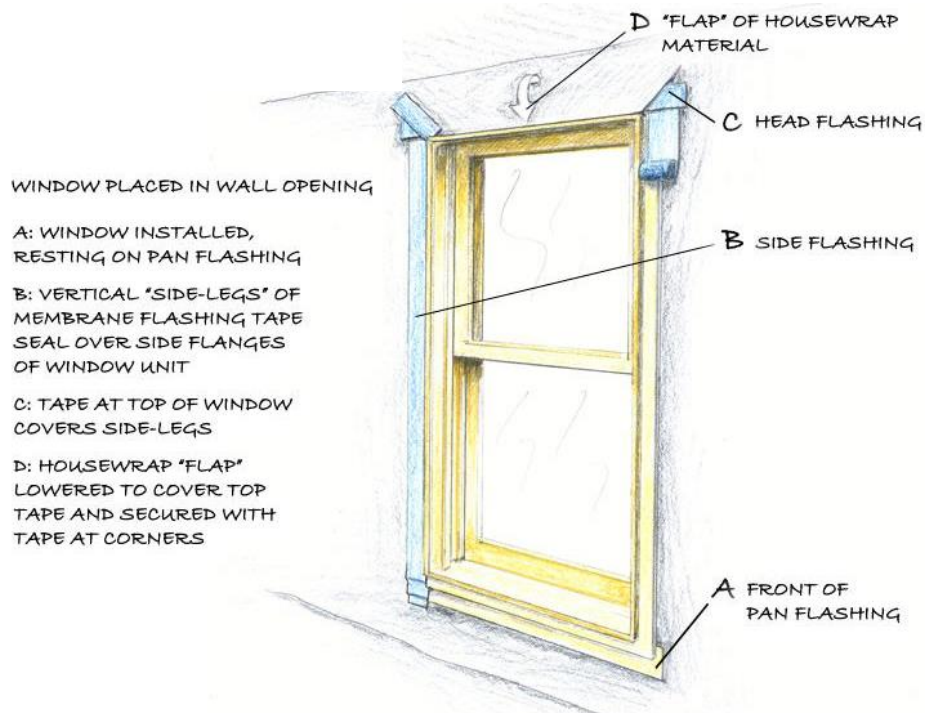

SOURCE: US EPA Indoor airPLUS

Figure 12: Step 5: Finishing window installation

Clarifications

Provide lapping as needed over lintels above window headers for brick cladding, or additional bond-break drainage plane layer provided behind all stucco and non-structural masonry cladding wall assemblies. Include weep holes for masonry veneer and weep screed for stucco cladding systems, according to the manufacturer's specifications.

Exemptions

Sheathing products with integrated drainage planes, such as OSB with built-in protective overlays and extruded polystyrene foam boards, are not required to have an additional drainage plane installed provided the product is installed per manufacturer's specifications.

Additional Resources

- [Moisture Control Guidance for Building Design, Construction, and Maintenance - EPA](#)

Confirmation

- The builder will illustrate compliance of criteria through photo documentation submitted to the EarthCraft Technical Advisor at pre-drywall.
- The EarthCraft Technical Advisor will review photo documentation provided by the builder for compliance of criteria.

DU 1.3 Double layer of either building paper or house wrap behind cementitious stucco, stone veneer or synthetic stone veneer on framed walls

Criteria

Install a double layer of either building paper or house-wrap behind stucco, stone veneer or synthetic stone veneer on framed walls in order to provide a drainage plane behind materials that absorb and retain moisture.

Clarifications

All unvented, exterior cladding in contact with the substrate must meet the criteria.

A single layer of building paper coupled with a single layer of house wrap meets the intent of the criteria.

For stucco cladding systems, include weep screed per manufacturer's specifications.

Additional Resources

- [Stucco Manufacturers Association](#)
- [Moisture Control Guidance for Building Design, Construction, and Maintenance - EPA](#)

Confirmation

- The builder will illustrate compliance of criteria through photo documentation submitted to the EarthCraft Technical Advisor at pre-drywall.
- The EarthCraft Technical Advisor will review photo documentation provided by the builder for compliance of criteria.

DU 1.4 Roof gutters discharge water ≥5' from foundation

Criteria

All rain from the roof must be collected in a roof gutter system and directed via downspouts such that water is discharged on a sloping finished grade ≥5' away from the foundation.

Clarifications

When grading is not possible, water must be directed to an underground catchment system (not connected to the foundation drain system) that deposits water a minimum of 10' from the foundation.

Roofs without gutters may be acceptable if rainwater is appropriately deposited to a grade-level rock bed with waterproof liner and drainpipe that discharges water according to the requirements above.

Rainwater-harvesting systems may be used to meet this requirement if they are able to drain overflow to meet requirements above.

For multifamily projects, non-permanent extensions do not qualify.

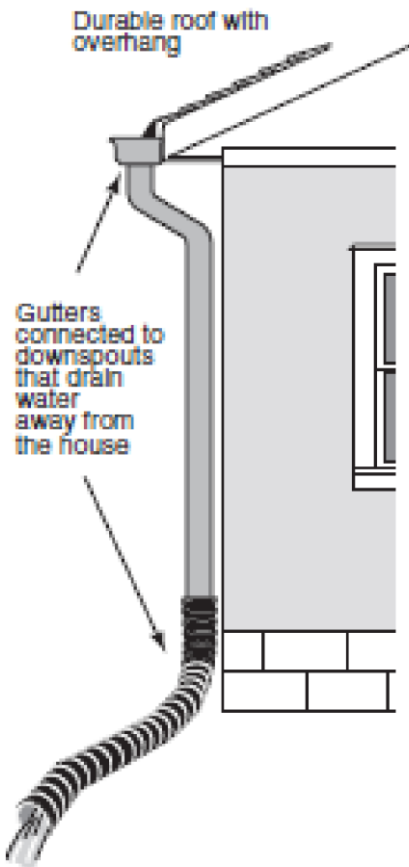

Figure 13: Roof gutters connected to downspout for proper drainage

Additional Resources

- [Moisture Control Guidance for Building Design, Construction, and Maintenance - EPA](#)

Confirmation

- The EarthCraft Technical Advisor will visually confirm compliance of criteria at final inspection.

DU 1.5 Flashing

Criteria

1. *Self-sealing bituminous membrane or equivalent at valleys and roof deck penetrations*

Install a self-sealing bituminous membrane or equivalent at all valleys and roof decking penetrations for added durability.

Install flashing on all roof penetrations and integrate with roof drainage plan.

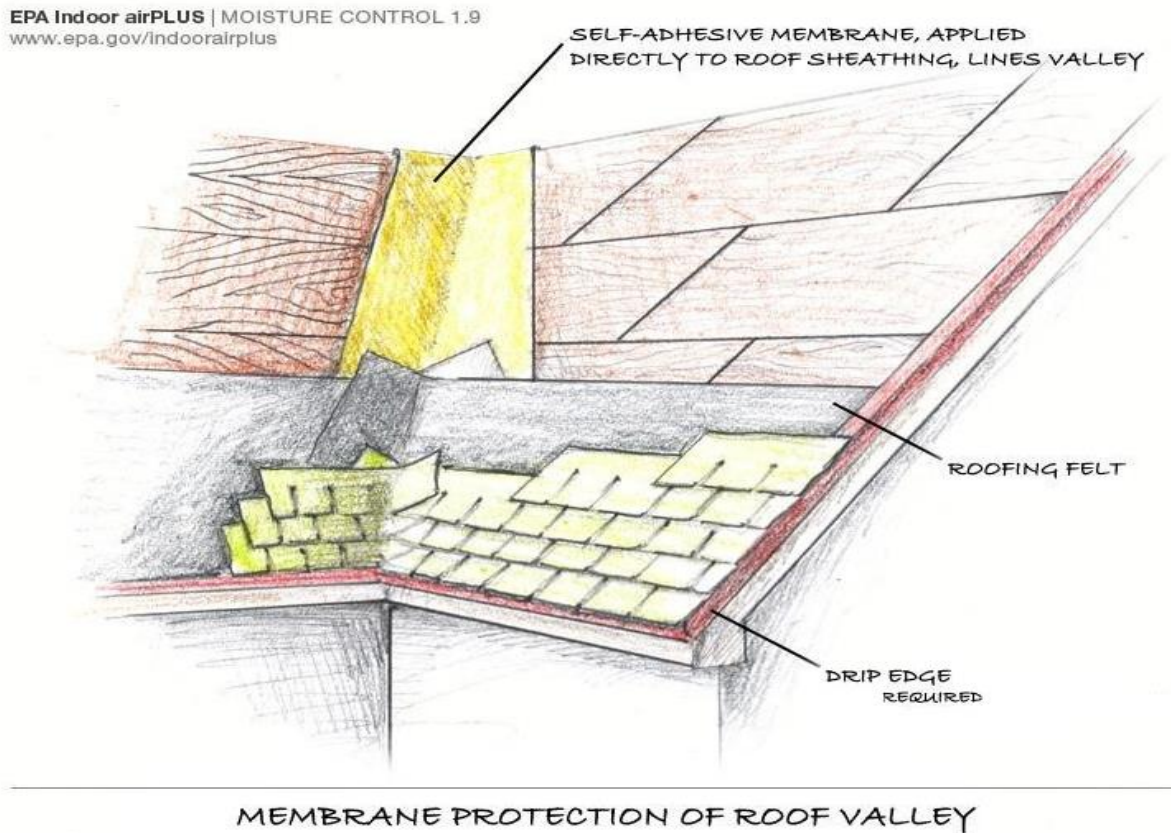

SOURCE: US EPA Indoor airPLUS

Figure 14: Membrane protection of roof valley

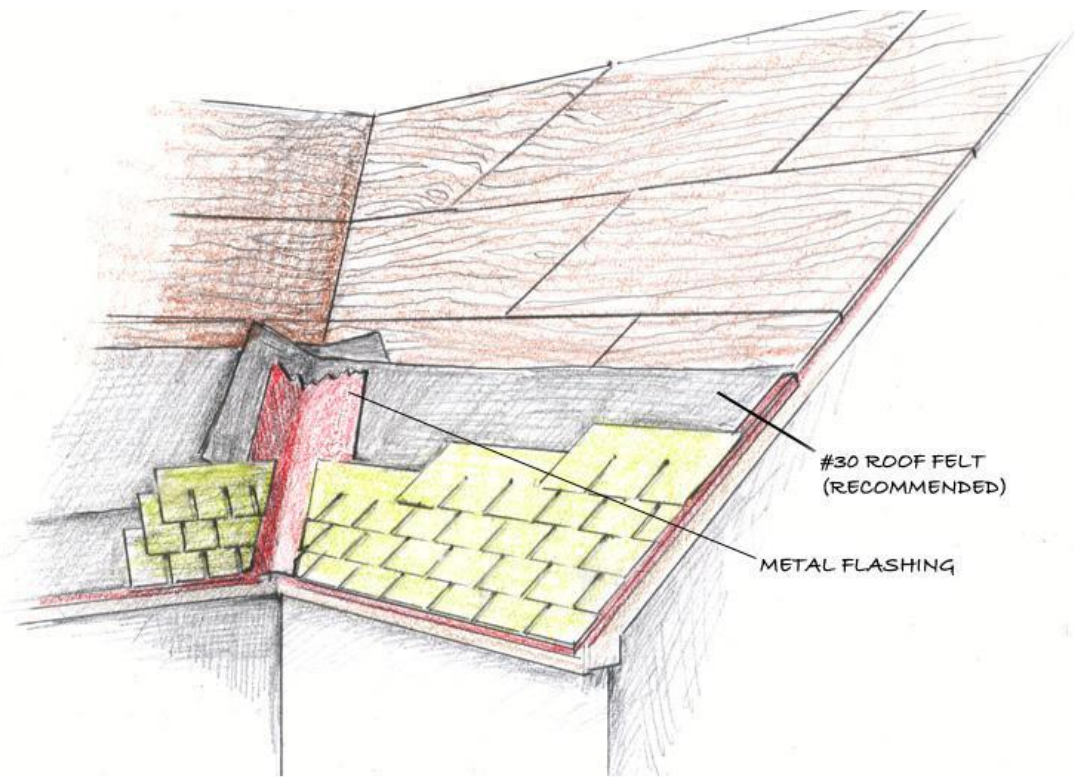

SOURCE: US EPA Indoor airPLUS

Figure 15: Metal coil stock flashing formed to valley

2. *Step and kick-out flashing at wall/roof and wall/porch intersections, flashing $\geq 4"$ on wall surface and integrated with wall and roof/deck/porch drainage planes*

Install step and kick-out flashing at all wall/roof and wall/porch intersections. Extend flashing $\geq 4"$ on the wall surface above the roof deck and integrate flashing with wall and roof drainage plans.

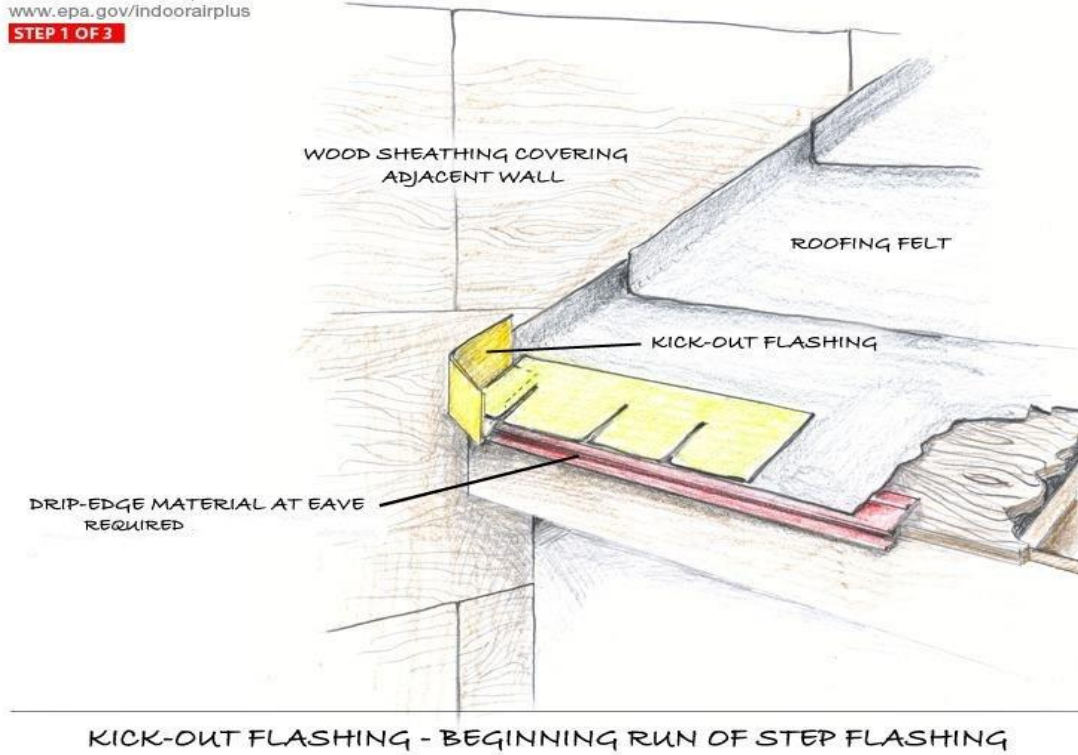

SOURCE: US EPA Indoor airPLUS

Figure 16: Step 1: Kick-out flashing beginning run of step flashing

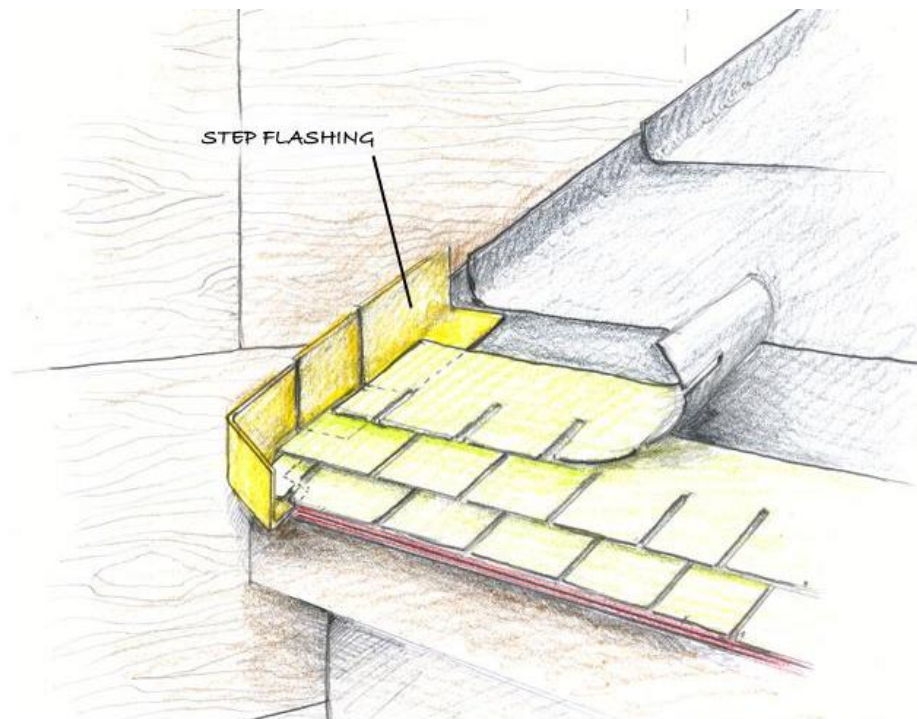

SOURCE: US EPA Indoor airPLUS

Figure 17: Step 2: Successive sections of step flashing integrated with courses of shingles

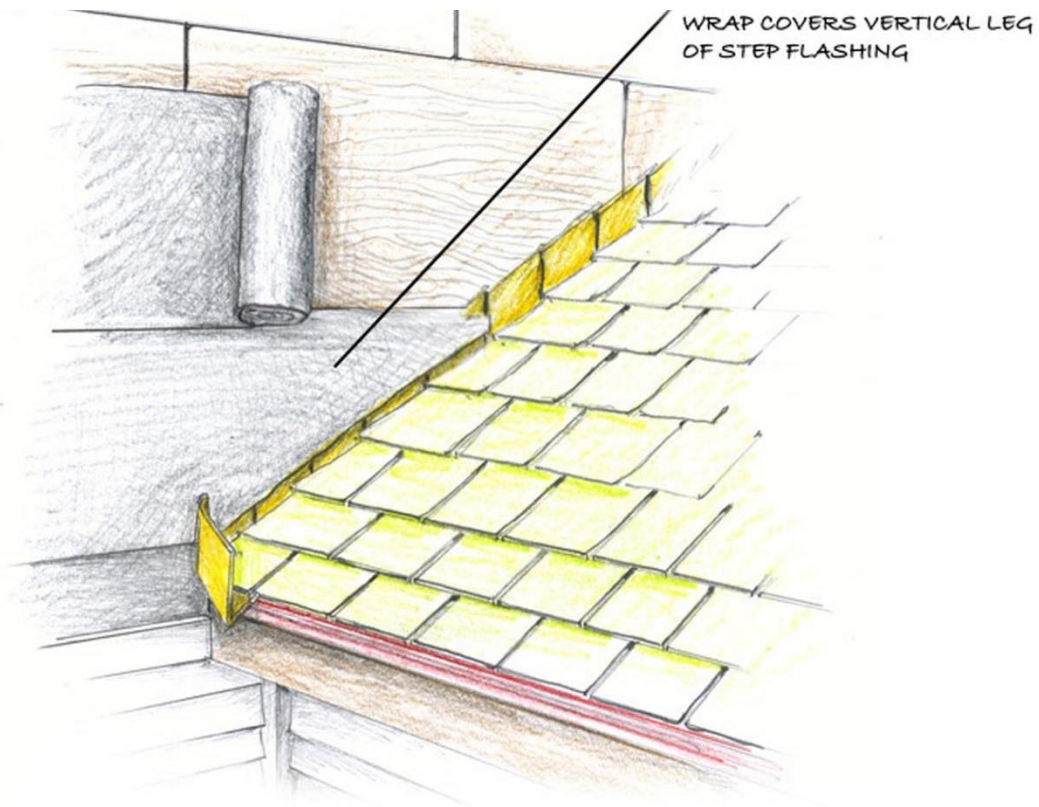

SOURCE: US EPA Indoor airPLUS

Figure 18: Step 3: Drainage plane material covers step flashing

Clarifications

For metal and rubber membrane roofs, install continuous flashing in place of step flashing.

For porches, install L-shaped flashing to the top of the ledger board and integrate with drainage plane (vertical leg of the flashing must extend along the wall above the ledger and the horizontal leg extends over the top of the ledger).

Additional Resources

- [Moisture Control Guidance for Building Design, Construction, and Maintenance - EPA](#)

Confirmation

- The builder will illustrate compliance of criteria through photo documentation submitted to the EarthCraft Technical Advisor at pre-drywall.
- The EarthCraft Technical Advisor will review photo documentation provided by the builder for compliance of criteria.

DU 1.6 Continuous foundation termite flashing (required if slab edge is insulated)

Criteria

Install a continuous termite shield that covers 100% of the foundation stem wall, piers, and other potential entry points. The termite shield can be fabricated from metal or similar material that forms a physical barrier to termites. All seams and penetrations in the termite shield must be effectively sealed to prevent termite entry

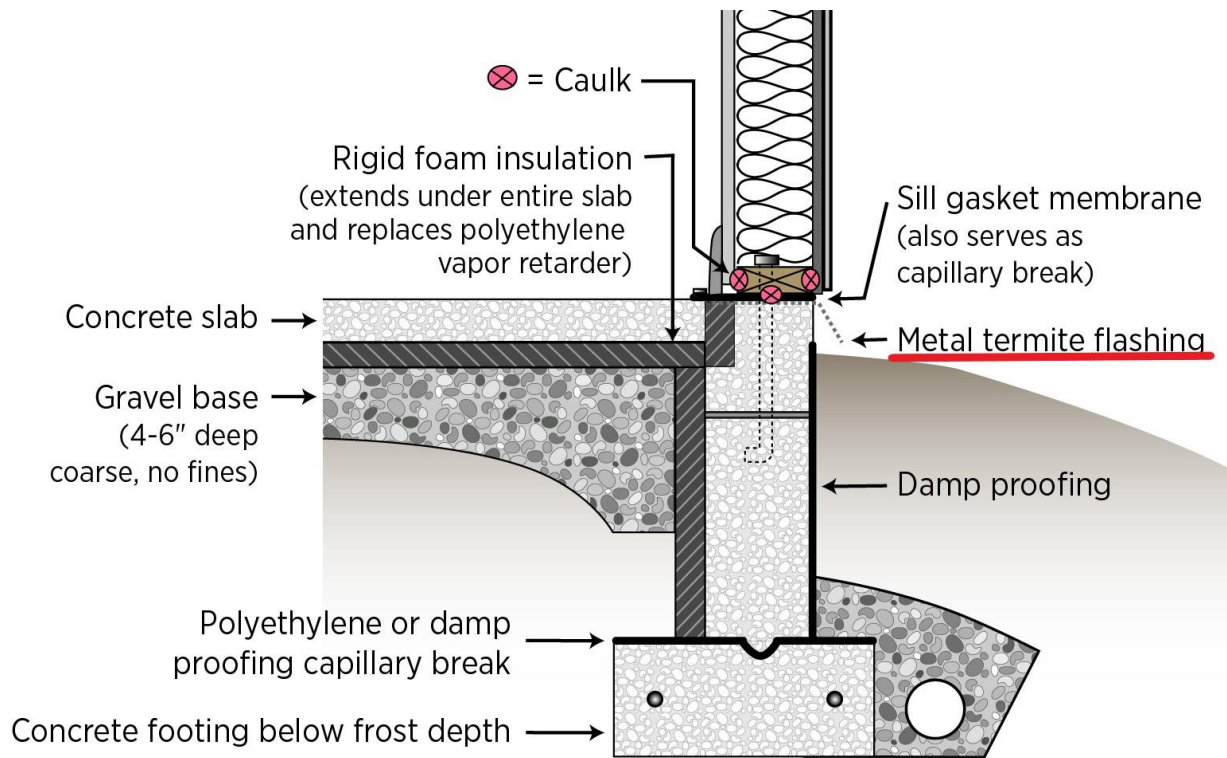

Source: U.S. Department of Energy

Figure 19: Continuous Termite Shield

Additional Resources

- [TERMITE AND WOOD DECAY CONTROL TECHNIQUES - ORNL Foundation Handbook](#)
- [Subterranean Termites - Their Control and Prevention in Buildings](#)

Confirmation

- The project team will illustrate compliance through details and specifications
- Project team must provide section details prior to the construction

DU 1.7 Maintain 2" clearance between wall siding and roof surface

Criteria

Terminate wall siding a minimum of a 2" above roof surface unless otherwise directed by product manufacturer installation specifications.

Additional Resources

- [Moisture Control Guidance for Building Design, Construction, and Maintenance - EPA](#)

Confirmation

- The EarthCraft Technical Advisor will visually confirm compliance of criteria at pre-drywall inspection.

DU 1.8 Install air conditioner condensing unit pad

Criteria

Install condenser unit pad for all outdoor air-conditioner and heat pump condensing units.

Confirmation

- The EarthCraft Technical Advisor will visually confirm compliance of criteria at final inspection.

DU 1.9 Roof drip edge with $\geq 1/4$ " overhang

Criteria

Protect the outer edge of all roof decking with a metal or plastic drip edge that has a minimum $1/4$ " overhang beyond the exterior roofing material.

Additional Resources

- [Moisture Control Guidance for Building Design, Construction, and Maintenance - EPA](#)

Confirmation

- The EarthCraft Technical Advisor will visually confirm compliance with criteria at pre-drywall inspection.

DU 1.10 Drain pan for water heaters and washing machines

Criteria

Install an appropriately sized drain pan underneath all hot water heaters and washing machines. Drain pan must discharge into a drain or system terminating at least 10' away from foundation to daylight, into sewer system or another site-approved drainage system such as drywell.

Confirmation

- The EarthCraft Technical Advisor will visually confirm compliance with criteria at final inspection.

DU 1.11 Enclosed crawl space if applicable to design

Criteria

If installed, crawl space must be closed. No vents are allowed. Crawl space must be conditioned.

Additional strategies required to meet this credit intent include but are not limited to:

- DU 2.1 100% coverage of ≥ 6 mil vapor barrier in crawl space or beneath slab
- DU 2.6 Capillary break
- IAQ 1.1 Sealed-combustion furnace or isolate furnace from conditioned space
- IAQ 1.2 Sealed-combustion, power vent or electric water heater, or isolate water heater from conditioned space
- BE 1.5 Seal penetrations through: foundation walls
- BE 1.9 Install weather stripping at all exterior doors
- BE 3.16 Seal and insulate crawl space walls

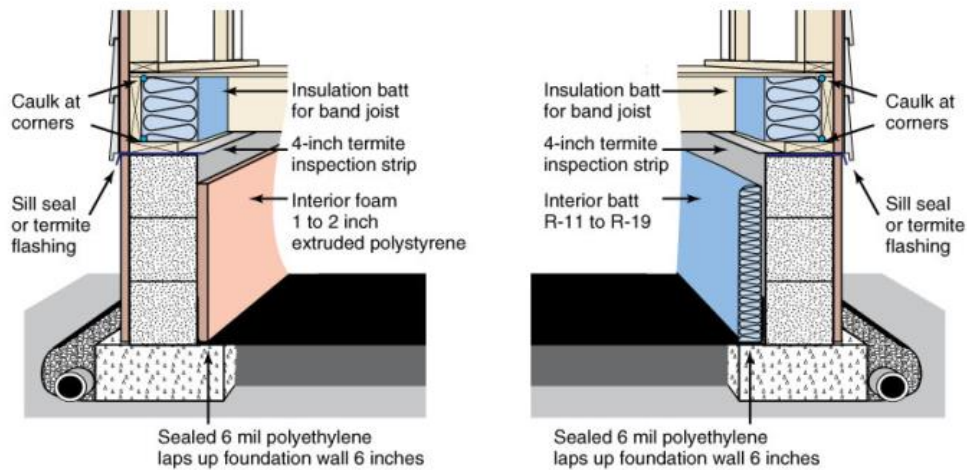

Figure 20: Enclosed crawl space with insulation along walls

Clarifications

Projects built on 100-year flood plains are not eligible to earn this credit.

Drainage, pests and combustion safety issues are important considerations when sealing a crawl space.

Example

Conditioning may involve one of the following methods:

- Continuously operated mechanical exhaust ventilation at a rate of 1 cfm for each 50 sq ft of crawl space floor area including a make-up air pathway to the main living area such as a transfer grill.
- Conditioned air supply (e.g. via supply duct) sized to deliver a rate of 1 cfm for each 50 sq ft of crawl space area.
- DU 2.17-B Additional dehumidification system: Basement or sealed crawl space system.

Additional Resources

- [Oak Ridge National Laboratory Foundation Handbook](#)
- [Advanced Energy Quick Reference on Enclosed Crawl Spaces](#)
- [Advanced Energy Intro to Closed Crawl Spaces](#)

Confirmation

- The EarthCraft Technical Advisor will visually confirm compliance of criteria at pre-drywall and final inspections.

DU 1.12 Moisture-resistant wallboard in bathrooms

Criteria

Install cement board, fiberglass enhanced sheathing or equivalent moisture-resistant backing material on walls behind bathroom sinks, and tubs and showers with tile or panel assemblies with caulked joints. Install moisture-resistant backing material in accordance with manufacturer specifications.

Moisture-resistant gypsum board must be installed on exposed walls and ceilings above tubs and showers where the wall is not covered by tile or a panel assembly.

Moisture-resistant gypsum board must be installed on exposed walls behind bathroom sinks and kitchen sinks when the wall is not covered by tile or other water-resistant splash back assemblies.

Clarifications

Do not use paper-faced backer-board or gypsum-based backer-board (i.e., green board) behind sink, tub, and shower assemblies.

Confirmation

- The EarthCraft Technical Advisor will visually confirm compliance with criteria at pre-drywall inspection.

DU 1.13 Flashing at bottom of exterior walls integrated with drainage system

Criteria

Install flashing at bottom of all exterior walls and properly integrate flashing with wall water management details to direct water out of and away from wall. Flashing at the bottom of exterior walls must be integrated into a continuous drainage plane.

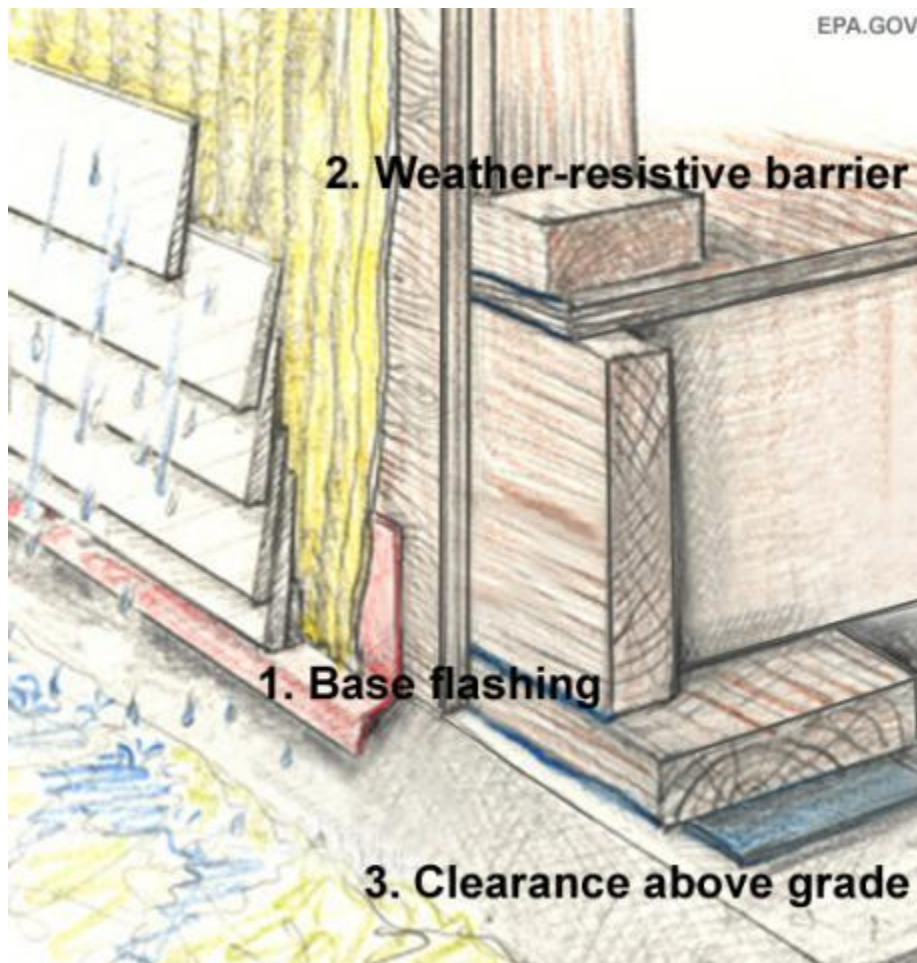

Figure 21: Base flashing at the bottom of exterior walls

Source: U.S. Department of Energy

Additional Resources

- [Flashing at Bottom of Exterior Walls - BASC](#)

Confirmation

- Wall Section details indicate compliance at Design Review
- The EarthCraft Technical Advisor will visually confirm compliance of criteria at pre-drywall and final inspections.

DU 1.14 Alternative Termite Treatment with no soil pretreatment

Criteria

Install an alternative termite treatment system with no soil pretreatment.

Provide information on type of system, maintenance, and monitoring requirements in project-specific owner's manual.

Confirmation

- The project team will illustrate compliance with criteria through photo documentation submitted to the EarthCraft Technical Advisor at pre-drywall.
- The EarthCraft Technical Advisor will review photo documentation provided by the project team for compliance with criteria.

DU 1.15 Non-toxic pest treatment

Criteria

1. *All lumber in contact with foundation (≥36" above foundation)*

Pre-treat all lumber in contact with the foundation with a non-toxic pest treatment such as borate. Lumber must be treated to a minimum height of 3' above the foundation.

2. *All lumber*

Pre-treat all lumber with a non-toxic pest treatment such as borate.

3. *Mold inhibitor with warranty applied to lumber*

Apply a non-toxic mold inhibitor with warranty to all lumber.

Confirmation

- The project team must present documentation demonstrating compliance with criteria to the EarthCraft Technical Advisor at the pre-drywall inspection.
- The EarthCraft Technical Advisor will review documentation provided by the project team for compliance with criteria.

DU 1.16 Vented rain screen behind exterior cladding

Criteria

All exterior wall area must have a weather resistive barrier such as building paper, house-wrap or similar material designed to protect the wall from water moving past the exterior cladding, and have an air space of at least 3/8" between the exterior cladding and weather resistive barrier.

The system must be integrated with flashing and be designed and installed to minimize moisture migration between the exterior cladding and the wall sheathing.

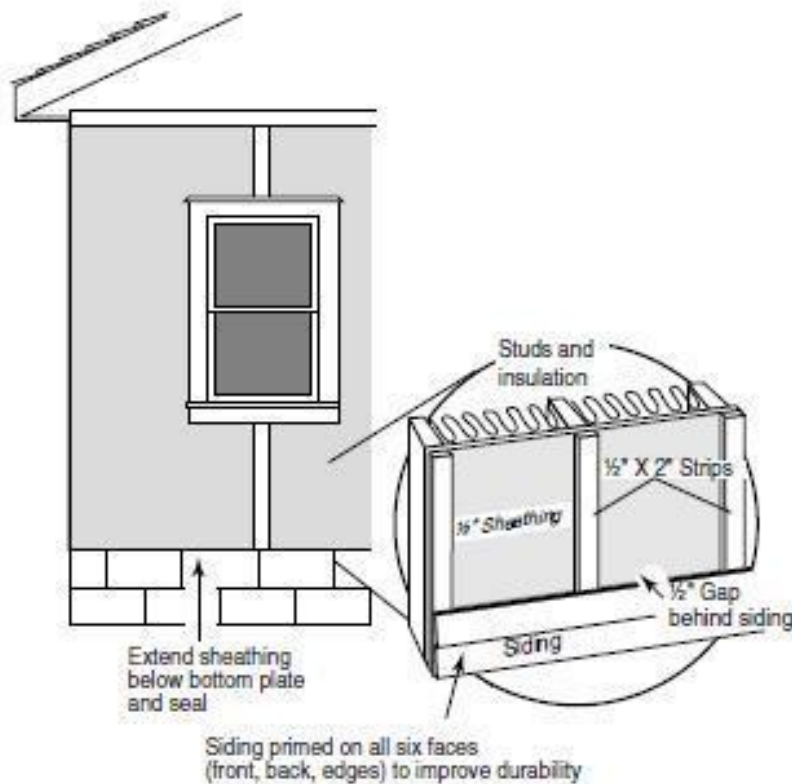

Figure 22: Site-built vented rain screen

Clarifications

If installing masonry veneer, install full-head weep holes with a minimum 24" on center spacing.

Additional Resources

- [Wood/Fiber Cement Rain-Screen Assembly - BASC](#)
- [Brick Veneer Assembly - BASC](#)

Confirmation

- The builder will illustrate compliance of criteria through photo documentation submitted to the EarthCraft Technical Advisor at pre-drywall.
- The EarthCraft Technical Advisor will review photo documentation provided by the builder for compliance of criteria.

DU 1.17 Install termite mesh system

Criteria

Install a termite mesh system that conforms to ASTM A 478 and ASTM A 580/A 580M, Type A1AA marine grade 316 stainless steel mesh of 0.18 mm (0.007") diameter wire with mesh openings of 0.66 x 0.45 mm. (0.026" x 0.018"). Follow manufacturer's installation specifications for proper termite prevention.

Confirmation

- The project team must present documentation demonstrating compliance with criteria to the EarthCraft Technical Advisor at the pre-drywall inspection.
- The EarthCraft Technical Advisor will review documentation provided by the project team for compliance with criteria and will visually confirm at pre-drywall inspection.

DU 1.18 Exterior cladding (≥75% facade) with 30-year warranty

Criteria

1. *Exterior cladding (≥75% facade) with 30-year warranty*

Install exterior wall cladding with a 30-year manufacturer's warranty or constructed from durable natural material, such as masonry, stucco, stone or brick on a minimum of three sides of the building.

Confirmation

Exterior cladding with 30-year warranty

- The project team must present documentation demonstrating compliance with criteria to the EarthCraft Technical Advisor at the pre-drywall inspection.
- The EarthCraft Technical Advisor will review documentation provided by the project team for compliance with criteria and will visually confirm at pre-drywall inspection.

DU 1.19 Windows, doors and skylights with ≥25-year warranty

Criteria

All installed exterior windows, doors and skylight assemblies must have ≥25-year manufacturer's warranty.

Confirmation

- The project team must present documentation demonstrating compliance with criteria to the EarthCraft Technical Advisor at the pre-drywall inspection.
- The EarthCraft Technical Advisor will review documentation provided by the project team for compliance with criteria.

DU 1.20 Insulate cold water pipes ≥R-2

Criteria

Insulate all cold-water pipes located inside conditioned spaces and in inaccessible interstitial locations (e.g., in walls, floor cavities, etc.) to ≥R-2 for condensation prevention.

Confirmation

- The EarthCraft Technical Advisor will visually confirm compliance with criteria at pre-drywall inspection.

DU 1.21 All entrance doors have overhang ≥3' depth

Criteria

On all exterior doors, including building entrances and exits, install a covered entry way that extends 3' out from door.

Confirmation

- The EarthCraft Technical Advisor will visually confirm compliance with criteria at final inspection.

DU 1.22 Roofing warranty

Criteria

A. 40-year warranty

Install shingles or other exterior roofing material that have \geq 40 year manufacturer's warranty.

B. 50-year warranty

Install shingles or other exterior roofing material that have \geq 50 year manufacturer's warranty.

Confirmation

- The project team must provide submittal documentation to EarthCraft Project Manager
- The EarthCraft Technical Advisor will review documentation and visually verify install.

Moisture Management (DU 2)

DU 2.0 Gravel bed beneath sub-grad slabs, on grade slabs, or raised slabs

Criteria

Install a ≥ 4 " deep gravel bed (consisting of ≥ 0.5 " clean aggregate) beneath all sub-grade concrete floor slabs.

OR

Install a ≥ 4 " of uniform layer of sand with geotextile drainage matting.

EPA Indoor airPLUS | MOISTURE CONTROL 1.2
www.epa.gov/indoorairplus

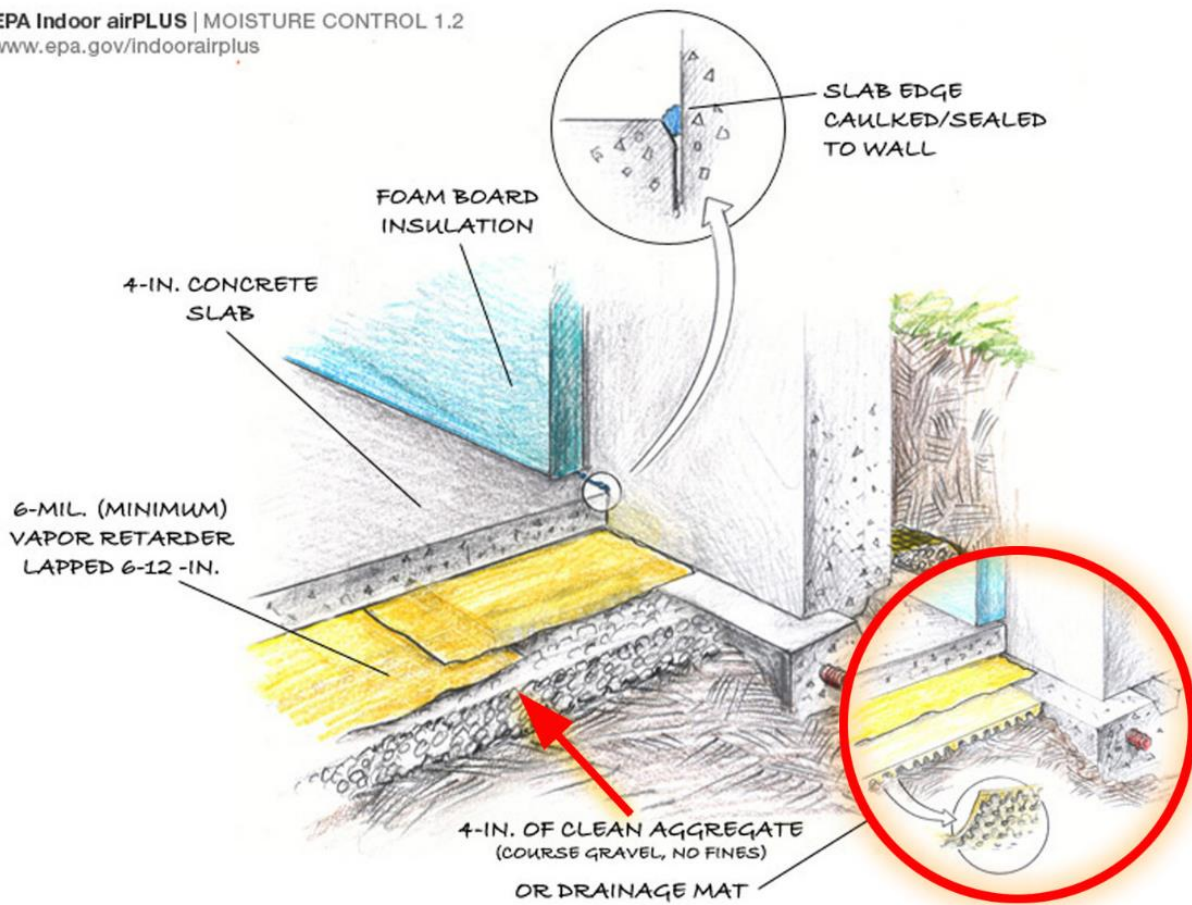

BASEMENT SLAB W/ CAPILLARY BREAK - GRAVEL AND GEOTEXTILE MAT (INSET)

Source: U.S. Department of Energy

Figure 23: Slab installed over 4" of clean aggregate with a vapor barrier with overlapping seams. (Inset) A geotextile drainage mat may be used in place of the gravel when installed on a 4" bed of sand.

Clarifications

Gravel bed must be installed beneath vapor barrier. Alternative sub-slab drainage systems will be considered on a case-by-case basis.

Additional Resources

- [Resource Guides for Capillary Break Beneath Slab Polyethylene Sheeting or Rigid Insulation Over O](#) | [Resource Guides for Capillary Break Beneath Slab Polyethylene Sheeting or Rigid Insulation Over O](#) (Permalink)

Confirmation

- The builder will illustrate compliance of criteria through photo documentation submitted to the EarthCraft Technical Advisor at pre-drywall.
- The EarthCraft Technical Advisor will review photo documentation provided by the builder for compliance of criteria.

DU 2.1 100% coverage of ≥ 6 mil vapor barrier beneath all slabs

Criteria

Install a vapor barrier ≥ 6 mil beneath all slabs to prevent soil moisture and gases from entering the building. Provide 100% coverage. Overlap all vapor barrier joints a minimum of 6”.

Confirmation

- The EarthCraft Technical Advisor will visually confirm compliance of criteria at pre-drywall inspection.

DU 2.2 Foundation drain on top of sub-grade footing

Criteria

Install a protected foundation drain tile on top of the footing. Use appropriate drain elbows for bends to prevent drainage constriction around corners. Surround each pipe with ≥ 6 ” of 1/2”- 3/4” gravel and wrap gravel layer fully with fabric cloth. Discharge all drain lines either away and downhill from the foundation to outside grade/daylight, drywell or to a sump pump.

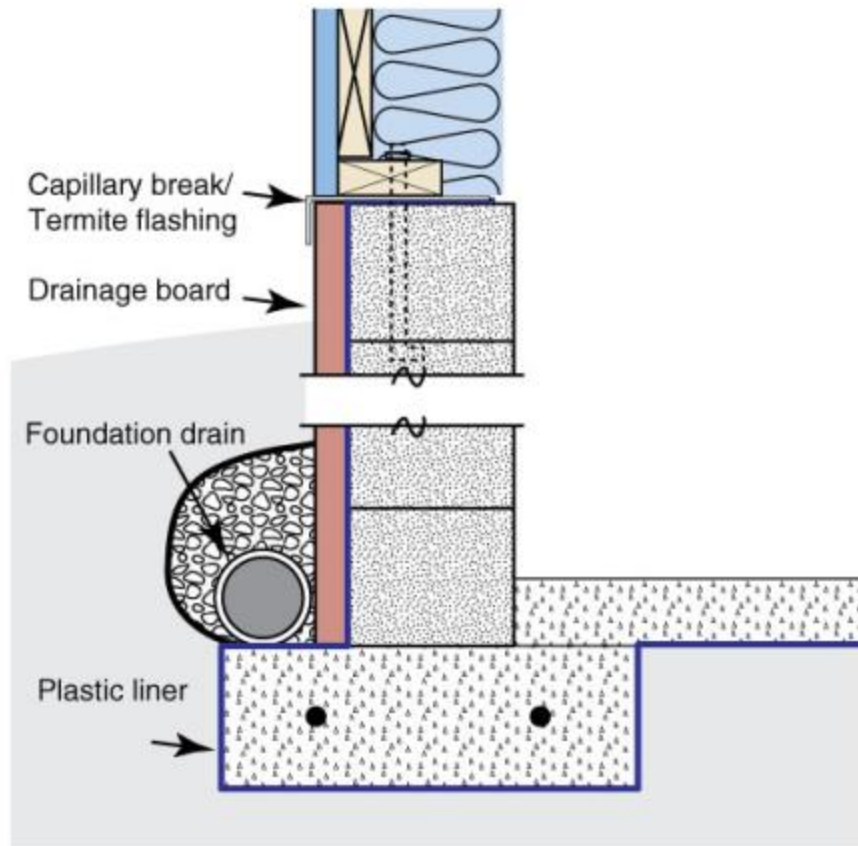

Figure 24: Foundation drain on top of footing

Clarifications

Installing the foundation drain at the outside perimeter edge of sub-grade footing and meeting the criteria of DU 2.10 meets this requirement.

Confirmation

- The builder will illustrate compliance of criteria through photo documentation submitted to the EarthCraft Technical Advisor at pre-drywall.
- The EarthCraft Technical Advisor will review photo documentation provided by the builder for compliance of criteria.

DU 2.3 Patio slabs, walks and driveways sloped $\geq 1/4"$ per 1' away from building for $\geq 10'$ or to the edge of the surface, whichever is less

Criteria

Slope patio slabs, porch slabs, walks and driveways a minimum of $1/4"$ per 1' away from house over a minimum distance of 10', or to the end of the slabs, walks and driveways. Tamp back-fill to prevent settling under patio slabs, walks and driveways unless proper drainage can be achieved using non-settling compact soils, as determined by a certified hydrologist, soil scientist or engineer.

Clarifications

Where setbacks limit space to less than 10', install swales or drains designed to carry water away from the foundation.

Confirmation

- The EarthCraft Technical Advisor will visually confirm compliance of criteria at final inspection.

DU 2.4 Final site grade sloped $\geq 1/2"$ per 1' away from building for $\geq 10'$ or to the edge of the site, whichever is less

Criteria

Slope final site grade away from the foundation at a rate of $1/2"$ per 1' over a minimum distance of 10 feet. Tamp back-fill to prevent settling unless proper drainage can be achieved using non-settling compact soils, as determined by a certified hydrologist, soil scientist, or engineer.

Clarifications

Where setbacks limit space to less than 10 feet, install swales or drains designed to carry water away from the foundation.

Confirmation

- The EarthCraft Technical Advisor will visually confirm compliance of criteria at final inspection.

DU 2.5 Do not install wet or water-damaged building materials

Criteria

Do not install building materials that have visible signs of water damage or mold.

Clarifications

If the framing members or insulation has high moisture content (framing members should be dried to at least 16% moisture content), do not enclose interior walls. Follow the manufacturer's drying recommendations for wet-applied insulation and test framing members for moisture prior to enclosing wall cavities.

Confirmation

- The EarthCraft Technical Advisor will visually confirm compliance of criteria at pre-drywall inspection.

If high moisture was present

- The builder must present documentation demonstrating compliance of criteria to the EarthCraft Technical Advisor at the pre-drywall inspection.
- The EarthCraft Technical Advisor will review documentation provided by the builder for compliance of criteria.

DU 2.6 Capillary break between foundation and framing at exterior walls

Criteria

Install a capillary break between a concrete foundation wall/slab floor and sill plate. Install either a complete framed wall width sill gasket, EPDM-type rubber, sheet metal or other suitable membrane to prevent moisture from wicking through the foundation into the framing. Capillary break should be installed at all exterior wall locations.

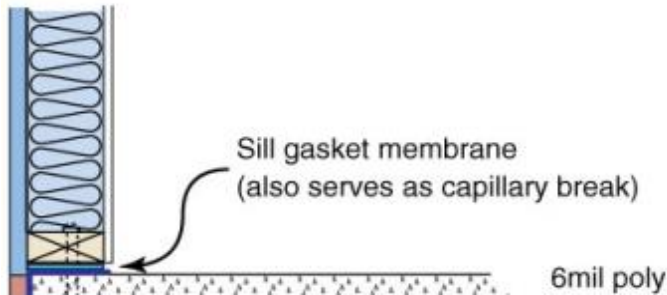

Figure 25: Capillary break Installation

Confirmation

- The EarthCraft Technical Advisor will visually confirm compliance with criteria at pre-drywall inspection.

DU 2.7 Drainage board and damp proofing for below-grade walls

Criteria

Apply damp proofing and install a drainage plane material that channels water down to the footing drain tile for all below-grade walls.

Clarifications

Wood-framed below-grade walls are not allowed along the exterior of the building.

Do not install Class 1 vapor retarders on the interior side of air permeable insulation in exterior below-grade walls, except for tile at showers and tub walls. Mirrors may be used if they are mounted with clips or other spacers that allow air to circulate behind them.

Additional strategies required to meet the intent of this credit include but are not limited to:

- BE 1.0 Install vapor barriers only under slabs and on crawl space floors

Confirmation

- The project team will illustrate compliance with criteria through photo documentation submitted to the EarthCraft Technical Advisor at pre-drywall.
- The EarthCraft Technical Advisor will review photo documentation provided by the project team for compliance with criteria.

DU 2.8 Design for or install additional dehumidification: rough-in electrical and plumbing for dehumidifier

Criteria

Rough in electrical and plumbing capacity for dehumidification system to deal with elevated levels of humidity within dwelling units if necessitated. Dehumidifier must discharge into a drain or at least 10' away from foundation to daylight, into sewer system

or another site-approved drainage system such as drywell. System must be able to drain without tenant interaction.

Clarification

For comfort, durability, and indoor air quality, recommended levels of relative humidity range from 40-50%. Continuous Ventilation and Dedicated Outdoor Air Systems with ability to deliver tempered outdoor air at a set Relative Humidity of 55% or below also comply with requirement.

Confirmation

- Mechanical Design will clearly specify location and intended product used as basis of design at Design Review.
- The EarthCraft Technical Advisor will review photo documentation provided by the builder for compliance of criteria.

DU 2.9 Additional dehumidification system: basement or sealed crawl space system

Criteria

Install either a basement or crawl space (if the crawl space is sealed) dehumidification system to maintain basement/crawl space at $\leq 60\%$ relative humidity. Dehumidifier must discharge into a sump pump or at least 10' away from foundation to daylight, into sewer system or another site-approved drainage system such as drywell.

Clarifications

Equipment must be installed to maintain indoor relative humidity levels $\leq 60\%$ relative humidity.

Confirmation

- Mechanical Design will clearly specify location and intended product used as basis of design at Design Review.
- The EarthCraft Technical Advisor will review photo documentation provided by the builder for compliance of criteria.

DU 2.10 Foundation drain at **outside perimeter edge of footing surrounded with 6"** clean gravel and fabric filter

Criteria

Install a protected foundation drain tile along the outside perimeter edge of the footing. Use appropriate drain elbows for bends to prevent drainage constriction around corners, or use an EarthCraft approved product that meets the same intent. Surround each pipe with at least 6" of 1/2" to 3/4" gravel. Wrap gravel layer fully with fabric cloth. Discharge all drain lines either away and downhill from the foundation to outside grade/daylight or to a sump pump.

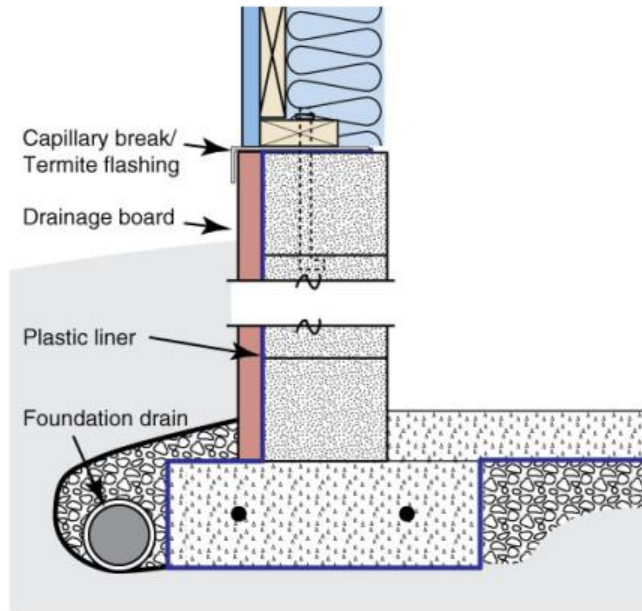

Figure 26: Foundation drain next to footing

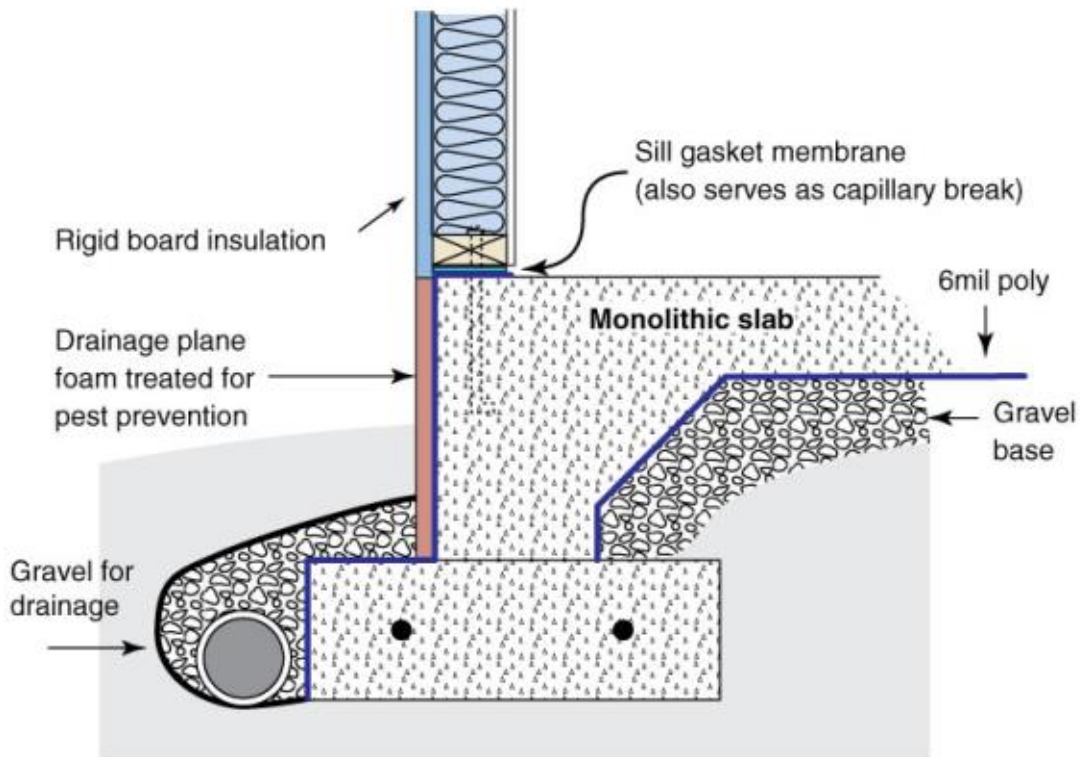

Figure 27: Foundation drain next to footing

Clarifications

If radon-resistant features are installed and drain tile discharges to daylight, install a check valve at the drain tile outfall.

Confirmation

- The builder will illustrate compliance of criteria through photo documentation submitted to the EarthCraft Technical Advisor at pre-drywall.
- The EarthCraft Technical Advisor will review photo documentation provided by the builder for compliance of criteria.

DU 2.11 Install whole-house ENERGY STAR dehumidifier

Criteria

Install ENERGY STAR Rated whole-house dehumidification system to control humidity within dwelling units. Dehumidifier must discharge into a drain or at least 10' away from foundation to daylight, into sewer system or another site-approved drainage system such as drywell. System must be able to drain without tenant interaction.

Clarifications

Equipment must be installed to maintain indoor relative humidity levels $\leq 60\%$ relative humidity.

Additional Resources

- <https://www.energystar.gov/products>

Confirmation

- Mechanical Design will clearly specify location and intended product used as basis of design at Design Review.
- Technical Advisor will visually confirm at Final Inspection.

DU 2.12 Slab or crawl space vapor barrier ≥ 10 mil or reinforced

Criteria

Install either a ≥ 10 mil polyethylene vapor barrier or a ≥ 6 mil reinforced polyethylene vapor barrier over all exposed earth (above grade) in crawl spaces and below slabs. Overlap sheeting 6"-12" at the seams and seal at seams and to walls with mastic or other appropriate sealant. Provide 100% coverage. Wrap plastic up the walls to be above grade of exterior soil or 2', whichever is greater.

Confirmation

- The EarthCraft Technical Advisor will visually confirm compliance of criteria at pre-drywall inspection.

DU 2.13 Humidistat or thermidistat used with whole-house variable speed cooling system

Criteria

Install a humidistat or thermidistat used with an air handler equipped with a central variable speed blower on all heating and cooling equipment for additional moisture removal.

Clarifications

Equipment must be installed to maintain indoor relative humidity levels $\leq 60\%$ relative humidity.

Confirmation

- The EarthCraft Technical Advisor will visually confirm compliance of criteria at final inspection.

DU 2.14 Capillary break

Criteria

1. *Between ground and footing or between footing and foundation*

Install plastic to form a capillary break between the ground and the footing or between the footing and foundation. The capillary break must be continuous from the edge of the footing to the slab with an overlapping seam of at least 6" and integrated in with the foundation wall drainage system.

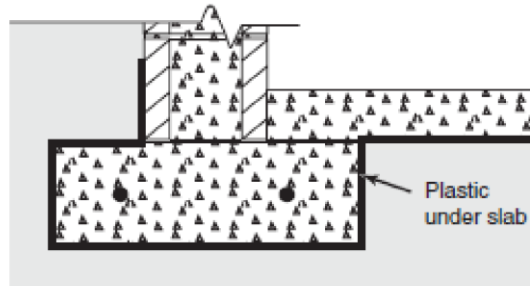

Figure 28: Capillary break between ground and footing

2. *Between foundation and framing for all walls*

Install a capillary break between a concrete foundation wall/slab floor and sill plate. Install either a complete framed wall width sill gasket, EPDM-type rubber, sheet metal or other suitable membrane to prevent moisture from wicking through the foundation into the framing. Capillary break should be installed between all foundations and sill plates, not just exterior walls.

Confirmation

Item 1

- The builder will illustrate compliance of criteria through photo documentation submitted to the EarthCraft Technical Advisor at pre-drywall.
- The EarthCraft Technical Advisor will review photo documentation provided by the builder for compliance of criteria.

Item 2

- The EarthCraft Technical Advisor will visually confirm compliance of criteria at pre-drywall inspection.

Indoor Air Quality (IAQ)

Combustion Safety (IAQ 1)

IAQ 1.0 No unvented combustion fireplaces, appliances, or space heaters

Criteria

Do not install unvented combustion space-heating appliances.

Clarifications

Vent all combustion fireplaces and appliances to remove combustion products as well as process fumes to the outside air.

Confirmation

- The EarthCraft Technical Advisor will visually confirm compliance of criteria at pre-drywall and final inspections.

IAQ 1.1 All fireplaces have outdoor combustion supply, masonry built have gasketed doors

Criteria

All fireplaces must use a supply duct supplying outside air for combustion that complies with the fire code. Masonry-built fireplaces must have gasketed glass doors.

Confirmation

- Provide product submittal to EarthCraft Project Manager and Technical Advisor
- The EarthCraft Technical Advisor will visually confirm compliance at install

IAQ 1.2 No atmospherically vented water heaters or furnaces

Criteria

Do not install atmospherically vented water heaters or furnaces.

Clarifications

All combustion water heaters and furnaces shall be power or direct vented.

Confirmation

- The EarthCraft Technical Advisor will visually confirm compliance of criteria at pre-drywall and final inspections.

IAQ 1.3 Sealed-combustion or electric water heater must be installed in conditioned space

Criteria

Install gas water heater that has direct venting or power venting located within conditioned space.

OR

Install electric water heater.

Clarifications

If installing sealed combustion water heater, provide combustion air from exterior of building in compliance with the mechanical code and manufacturer specifications.

Do not install atmospherically vented water heaters.

Confirmation

- The EarthCraft Technical Advisor will visually confirm compliance of criteria at pre-drywall and final inspections.

IAQ 1.4 Carbon monoxide detector (one per floor)

Criteria

Install one carbon monoxide (CO) detector per floor of dwelling unit, if combustion appliances exist. If all bedrooms are on the same floor, install the CO detector in a central location near all bedrooms. If central gas appliances in the building, one per floor applies to building. CO detectors must be certified by CSA 6.19-2017 or UL 2034.

Clarification

Combination smoke/CO detectors meet the intent provided they are certified by CSA 6.19-2017 or UL 2034.

Confirmation

- The EarthCraft Technical Advisor will visually confirm compliance of criteria at final inspection.

IAQ 1.5 All fireplaces meet indoor air quality guidelines and have gasketed doors

Criteria

All installed fireplaces must meet indoor air quality guidelines below and have gasketed doors.

Clarifications

Fireplaces that meet these guidelines include:

- Gas or propane powered, sealed combustion and direct or power vented as rated by the American Gas Association (AGA) with a permanently affixed glass front or gasketed door. Decorative gas log fireplaces that consist of an open flame-type appliance with a metal frame or base supporting simulated logs are not permitted.
- Masonry heaters as defined by ASTM E1602 and section 2112.1 of the International Building Code (i.e., fireplaces engineered to store and release substantial portions of heat generated from a rapid burn).
- Factory-built, wood-burning fireplaces that meet the certification requirements of UL 127 and emission limits found in the EPA Standard for New Residential Wood Heaters.
- Wood stove and fireplace inserts as defined in section 3.8 of UL 1482 that meet the certification requirements of that standard and meet the emission requirements of the EPA Standards for New Residential Wood Heaters and WAC 173-433-100 (3).
- Pellet stoves that meet the requirements of ASTM E1509.

Confirmation

- The project team must present documentation demonstrating compliance.
- The EarthCraft Technical Advisor will visually confirm compliance with criteria at final inspection.

Indoor Pollutant Control (IAQ 2)

IAQ 2.0 Protect all ducts until floor/wall finishing is complete

Criteria

All ducts in floors, ceilings, and side walls (return or supply) and all open returns must be protected to prevent construction debris from entering ductwork. Pleated filters are required upon early startup with a filter change halfway between startup and CO or do not run system prior to finish floor being installed.

Confirmation

- The EarthCraft Technical Advisor will visually confirm compliance of criteria at pre-drywall inspection.

IAQ 2.1 Filter(s) easily accessible for maintenance

Criteria

Install all filters in an easily accessible location. Easily accessible is defined as any location which facilitates access and regular filter changes by future occupant.

Clarifications

Filters located in attics are considered easily accessible if drop-down stairs provide access to attic and a permanently installed walkway has been provided between the attic access location and the filter. Filters located within the units (e.g., at the return grill) are also considered easily accessible. Filters located within crawl spaces are considered easily accessible if within 5' of the entrance or in crawls with a height of 4' or greater at walk area between entrance and filter.

Filters perform best when the filter rack design includes flexible, air tight (e.g., closed-cell foam) gasket material on the downstream side of the filter and friction fit or spring clips installed on the upstream side of the filter. Non-standard efficiency ratings for filters (e.g., 3M's Microparticle Performance Rating [MPR]) and filters that do not have a MERV rating (e.g., electrostatic filters) need prior approval by EarthCraft.

Filter doors should not be obstructed by any permanent fixtures including water heaters, washer and dryers, vents, condensate line or refrigerant line sets.

HVAC system design and installation must ensure accessible criteria are met.

Confirmation

- The EarthCraft Technical Advisor will visually confirm compliance with criteria at pre-drywall and final inspections.

IAQ 2.2 Provide rodent and corrosion proof screens with mesh \leq 0.5" for all openings not fully sealed or caulked

Criteria

Install corrosion-proof rodent/bird screens (e.g., copper or stainless steel) with a mesh 0.5" or greater on all building openings, such as ventilation system intake/exhaust outlets and attic/crawl space vent openings that cannot be fully sealed or caulked.

Clarifications

Clothes dryer vents should use a flap damper to prevent rodent entry.

Confirmation

- The EarthCraft Technical Advisor will visually confirm compliance of criteria at final inspection.

IAQ 2.3 All outdoor supply air crosses filter prior to distribution

Criteria

Design and install outdoor air supply ventilation so that all outdoor air crosses a filter prior to distribution.

Confirmation

- The EarthCraft Technical Advisor will visually confirm compliance with criteria at pre-drywall and final inspections.

IAQ 2.4 All interior paints have <100g/L VOC content

Criteria

Use only interior paints with a VOC content of <100g/L for common areas and for all units.

Confirmation

- The EarthCraft Technical Advisor will verify compliance with criteria at final inspection.
- The project team can submit product literature and order forms indicating compliance with the VOC content of interior paints.

IAQ 2.5 No carpet in below grade units

Criteria

Do not install carpet in any below grade units.

Confirmation

- The EarthCraft Technical Advisor will visually confirm compliance with criteria at final inspection.

IAQ 2.6 Filters are \geq MERV 8

Criteria

Install an HVAC filter with a MERV 8 or higher filtration (according to ASHRAE 52.2) on all HVAC systems. HVAC design and installation must account for airflow based on filter selection.

Confirmation

- The EarthCraft Technical Advisor will visually confirm compliance with criteria at final inspection.

IAQ 2.7 Certified low or no VOC materials

Criteria

1. *Interior paints*

Use only interior paints that are certified as low or no VOC by one of the following:

- Green Seal Standard GS-11
- Greenguard Certification for Paints and Coatings
- Scientific Certification Systems (SCS) Indoor Advantage Gold
- Master Painters Institute (MPI) Green Performance Standards GPS-1 or GPS-2

- a third-party low-emitting product list based on CA Section 01350

2. *Stains and finishes on wood floors*

Use only finishes on wood floors that are certified as low or no VOC by one of the following: Green Seal Standard GS-11, Greenguard Certification for Paints and Coatings, Scientific Certification Systems (SCS) Indoor Advantage Gold, Master Painters Institute (MPI) Green Performance Standards GPS-1 or GPS-2, or a third-party low-emitting product list based on CA Section 01350.

3. *Sealants and adhesives*

Use only interior sealants and adhesives that have a VOC (Volatile Organic Compound) content of 250 g/L or less.

4. *Carpet*

Install only carpet that qualifies as CRI Green Label or CRI Green Label Plus or has been tested and meets all the requirements of the CRI Green Label or CRI Green Label Plus testing program criteria.

5. *Carpet pad*

Install only carpet pad that qualifies as CRI Green Label Plus or has been tested to meet all the requirements of the CRI Green Label Plus testing program criteria.

6. *Carpet pad adhesive*

Install only carpet pad adhesives that qualify as CRI Green Label Plus or have been tested to meet all the requirements of the CRI Green Label Plus testing program criteria.

Additional Resources

- SCS Indoor Advantage Gold: <https://www.scsglobalservices.com/services/indoor-air-quality-certification>
- Sustainable Product Database: <https://spot.ul.com/>
- CRI Indoor Air Quality Carpet Testing Program: <https://carpet-rug.org/testing/green-label-plus/>

Confirmation

- The builder must present documentation demonstrating compliance of criteria to the EarthCraft Technical Advisor at the final inspection.
- The EarthCraft Technical Advisor will review documentation provided by the builder for compliance of criteria.

IAQ 2.8 Protect all bath fans until floor/wall finishing is complete

Criteria

Upon installation of all bath fans, seal all chases and openings to stop construction trash and dust from contaminating bath fan systems, and keep fans protected for the duration of construction.

Confirmation

- The EarthCraft Technical Advisor will visually confirm compliance with criteria at pre-drywall and final inspections.

IAQ 2.9 No added urea-formaldehyde

Criteria

1. *Insulation*

Do not install insulation that contains added urea-formaldehyde.

2. Subfloor

Do not install subflooring that contains added urea-formaldehyde.

3. All cabinets, shelves, and countertops

Do not install cabinetry, shelves and countertops that contain added urea-formaldehyde.

Additional Resources

- [SCS Certified Green Products](#)

Confirmation

Insulation and Subfloor

- The builder must present documentation demonstrating compliance of criteria to the EarthCraft Technical Advisor at the pre-drywall inspection.
- The EarthCraft Technical Advisor will review documentation provided by the builder for compliance of criteria.

Cabinets, Shelves, Countertops

- The builder must present documentation demonstrating compliance of criteria to the EarthCraft Technical Advisor at the final inspection.
- The EarthCraft Technical Advisor will review documentation provided by the builder for compliance of criteria.

IAQ 2.10 Seal all particle board surfaces with water-based sealant

Criteria

Seal all particle board surfaces by coating all unsealed sides with water based polyurethane sealant or a formaldehyde sealant. Sealant must have a VOC (volatile organic compounds) content of 100 g/L or less.

Confirmation

- The builder must present documentation demonstrating compliance of criteria to the EarthCraft Technical Advisor at the final inspection.
- The EarthCraft Technical Advisor will review documentation provided by the builder for compliance of criteria and will visually confirm compliance of criteria at final inspection.

IAQ 2.11 No carpet in all units

Criteria

Do not install carpet in units on any floor.

Confirmation

- The EarthCraft Technical Advisor will visually confirm compliance with criteria at final inspection.

IAQ 2.12 No Carpet in main living area of all units

Criteria

Do not install carpet in the main living area of all units including areas adjacent to unit entrances.

Clarifications

If the project achieves IAQ 2.11 No carpet in all units, these points cannot also be earned.

Confirmation

- The EarthCraft Technical Advisor will visually confirm compliance with criteria at final inspection.

IAQ 2.13 Install permanent walk-off mats at primary entrances

Criteria

Install a built-in walk-off mat at the main entrances to each building from the exterior.

Clarifications

Walk off-mats must be at least 2' in length and allow accessibility for cleaning (e.g., grating with catch basin).

Confirmation

- The EarthCraft Technical Advisor will visually confirm compliance of criteria at final inspection.

IAQ 2.14 Flush building before occupancy

Criteria

Flush building during and shortly after installing products that are known sources of contaminants (e.g., cabinets, carpet padding, painting) for a minimum of 48 hours prior to occupancy.

Example

To flush building, either keep all windows open and run interior fans (e.g., HVAC system fans, exhaust fans, fresh air ventilation fans, and interior circulation fans) continuously, or close exterior windows and doors and run all HVAC fans, exhaust fans, fresh air ventilation fans and interior circulation fans continuously at the highest rate. Keep all interior doors open, use additional fans to circulate air within buildings. Replace all filters after flushing building.

Confirmation

- The EarthCraft Technical Advisor will verbally confirm compliance of criteria with the builder at the final inspection.

High Performance Building Envelope (BE)

Energy Code and Energy Performance (BE 0)

BE 0.1 IECC adopted by jurisdiction plus applicable state amendments

Criteria

Building must meet the International Energy Conservation Code (IECC) adopted by the project's jurisdiction plus any applicable state amendments.

Clarifications

Where local code is more stringent than EarthCraft criteria, local code criteria must be met.

Additional Resources

- 2018 Virginia Energy Conservation Code is available through DHCD and the International Codes Council: <https://codes.iccsafe.org/content/VECC2018P1>
- [ASHRAE 90.1 - 2013/2016/2019 Code Resources](#) | [ASHRAE 90.1 - 2013/2016/2019 Code Resources](#) (Permalink)

Confirmation

- The EarthCraft Technical Advisor will visually confirm compliance with criteria at pre-drywall and final inspections.

BE 0.2 Energy Compliance: CERTIFIED LEVEL

Criteria

For CERTIFIED projects, complete worst-case unit level energy models based on actual construction and demonstrate a confirmed HERS Rating Index that is less than or equal to 75.

Adaptive Reuse Projects:

Adaptive Reuse Projects must follow the Adaptive Reuse tab within the workbook. No HERS Threshold applies.

Please contact Viridiant for further clarification on project related energy goals.

Adaptive Reuse Projects:

Any project changing transforming a building from a previously non-residential use. This may include warehouses, hotels, gyms, school buildings, or other similar types. The adaptive reuse may be historic in nature.

Additional Resources

- [What is the HERS Index?](#)
- [ASHRAE 90.1 - 2013/2016/2019 Code Resources](#) | [ASHRAE 90.1 - 2013/2016/2019 Code Resources](#) (Permalink)

Confirmation

When seeking HERS Compliance:

- The EarthCraft Project Manager will develop an energy model in accordance with RESNET modeling criteria and confirm compliance with criteria at pre-drywall and final inspections.
- The project team must present documentation demonstrating compliance with criteria to the EarthCraft Technical Advisor prior to pre-drywall inspections.

BE 0.3 Energy Compliance: GOLD or PLATINUM

Criteria

All Gold and Platinum Level projects must meet the ENERGY STAR Multifamily New Construction (ESMFNC) Target HERS Index.

Clarifications

The ENERGY STAR Multifamily New Construction Target Home is identical to the home that will be built, except that it is configured with the energy efficiency features of the Multifamily New Construction National Program Requirements Exhibit 1. The dwelling unit being constructed must be lower than or meet the Target HERS Index, as determined through energy modeling.

This item applies to the ENERGY STAR Multifamily New Construction ERI Path, compliance can also be shown by completing a building level simulation (eQUEST) based on actual construction and demonstrate compliance with ENERGY STAR Multifamily New Construction Prescriptive or ASHRAE Paths.

Adaptive Reuse Projects:

Adaptive Reuse Projects must follow the Adaptive Reuse tab within the workbook. No HERS Threshold applies.

Definitions

ENERGY STAR Target HERS Index: the HERS Index of ENERGY STAR's Reference Home

Additional Resources

- [ENERGY STAR Multifamily New Construction Program](#)
- [HERS Index Target Procedure](#)
- [What is the HERS Index?](#)
- [ASHRAE 90.1 - 2013/2016/2019 Code Resources](#) | [ASHRAE 90.1 - 2013/2016/2019 Code Resources](#) (Permalink)

Confirmation

- The EarthCraft Project Manager will develop an energy model in accordance with RESNET modeling criteria and confirm compliance with criteria at pre-drywall and final inspections.

BE 0.4 Confirmed HERS Index \leq Zero Energy Ready Home Target HERS Index

Criteria

The DOE Zero Energy Ready Home Target Home is identical to the home that will be built, except that it is configured with the energy efficiency features of the DOE Zero Energy Ready Home Target Home as defined in Exhibits 1 and 2 of the DOE Zero Energy Ready Home National Program Requirements. The HERS Index of the Target Home is automatically calculated in accordance with the RESNET Mortgage Industry National Home Energy Rating Standards.

Clarifications

Achieving this item does not indicate that the project has earned Zero Energy Ready Home certification. Additional steps are necessary to earn the certification. See the Additional Resources.

Additional Resources

- [Zero Energy Ready Home National Program Requirements](#)

Confirmation

- The EarthCraft Project Manager will develop an energy model in accordance with RESNET modeling criteria.

- The Technical Advisor will confirm compliance with the criteria at inspection points.

Air Sealing (BE 1)

BE 1.0 Install vapor barriers only under slabs and on crawl space floors and not on any vertical surfaces

Criteria

No polyethylene or other materials with a perm rating ≤ 0.1 , such as vinyl wallpaper, may be used on foundation or above grade walls, or in any other assembly except under slabs and on crawl space floors.

Clarifications

Tile is permitted on tub and shower walls and behind counters for backsplash protection.

Additional Resources

For perm ratings of materials, review manufacturer's product specifications or 2017 ASHRAE Handbook of Fundamentals, Chapter 25.

Confirmation

- The EarthCraft Technical Advisor will visually confirm compliance with criteria at pre-drywall inspection.

BE 1.1 Seal bottom plates to subfloor or foundation for entire unit envelope

Criteria

Using the appropriate sealant, seal the bottom plates of walls separating conditioned and unconditioned spaces to subfloor or foundation, including the bottom plate to subfloor connections in garage.

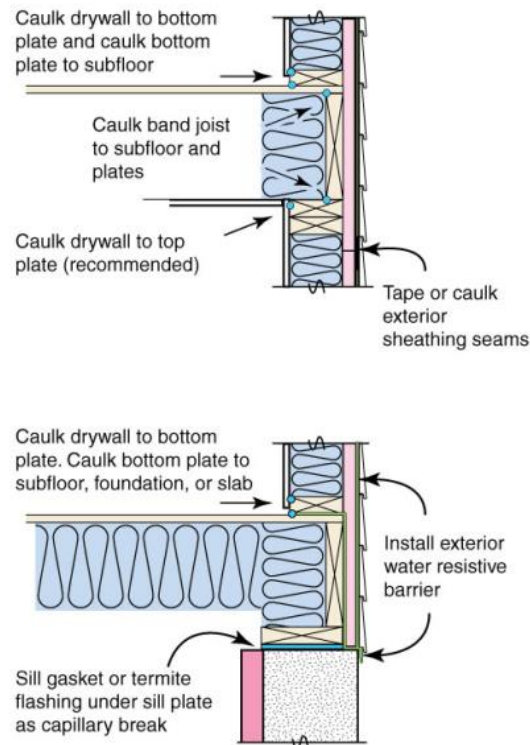

Figure 29: Sealed bottom plates

Clarifications

Foam gasket alone does not meet the criteria.

Example

An acceptable strategy is a foam gasket beneath the bottom plate in combination with a suitable sealant.

Additional Resources

- [Air Sealing Sill Plates | Building America Solution Center](#)

Confirmation

- The EarthCraft Technical Advisor will visually confirm compliance with criteria at pre-drywall inspection.

BE 1.2 Block and seal joist cavities

Criteria

1. Above supporting wall at cantilevered floors

Block and seal all cantilevered floor joist cavities above the top plate of the supporting wall using rigid blocking and appropriate sealant.

Seal exterior sheathing on bottom of cantilevered floor.

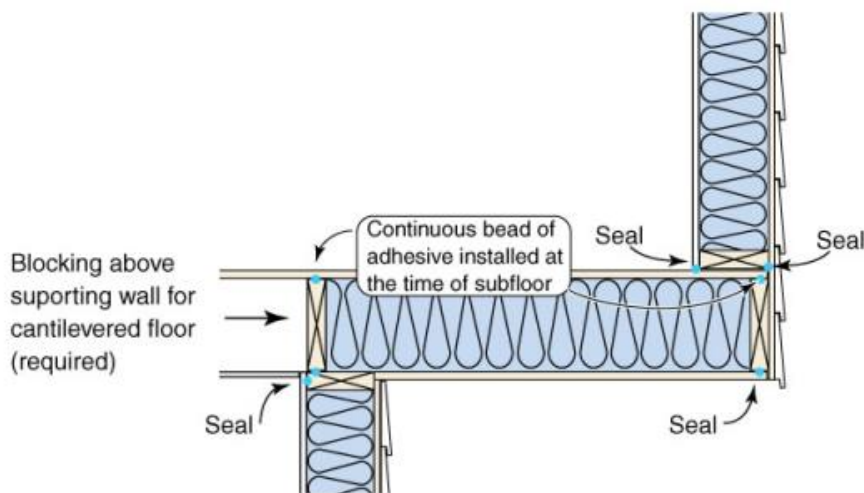

Figure 30: Cantilevered floor blocking

2. Under attic kneewalls

Block and seal all joist cavities below kneewalls using rigid blocking and appropriate sealant.

Clarifications

Attic kneewalls, defined as a vertical or near vertical wall separating conditioned space from unconditioned attic space which also include skylight shaft walls or walls adjacent to porch roofs.

Additional Resources

[Cantilevered Floor - Building America Solution Center](#) | [Cantilevered Floor - Building America Solutions Center](#) (Permalink)

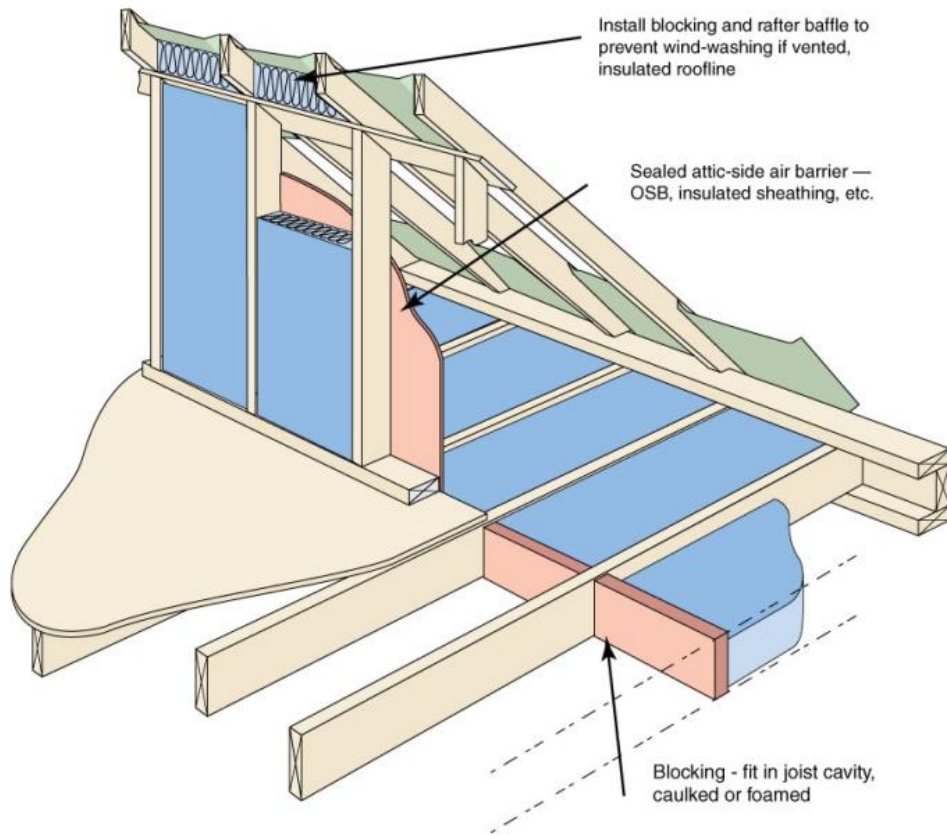

Figure 31: Attic kneewall blocking

Confirmation

- The EarthCraft Technical Advisor will visually confirm compliance of criteria at pre-drywall inspection.

BE 1.3 Block stud cavities at change in ceiling height

Criteria

Block stud cavities at locations of varying ceiling height, including common walls between adjacent rooms and dropped ceilings in hallways.

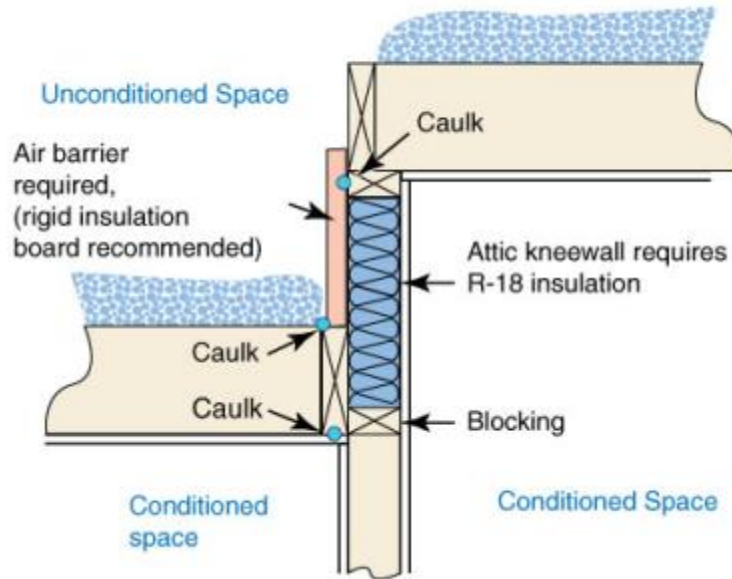

Figure 32: Blocking at change in ceiling height

Clarifications

Changes in ceiling height 18" or greater are considered attic kneewalls.

Confirmation

- The EarthCraft Technical Advisor will visually confirm compliance of criteria at pre-drywall inspection.

BE 1.4 Install blocking and baffles in insulated and vented attics

Criteria

Install blocking in rafter cavities above top plate of exterior wall if air-permeable insulation (e.g., fiberglass batts or cellulose insulation) is used and the roofing assembly must be ventilated. Blocking must be in contact with rafter baffle to allow proper roof deck ventilation and prevent wind-washing of insulation.

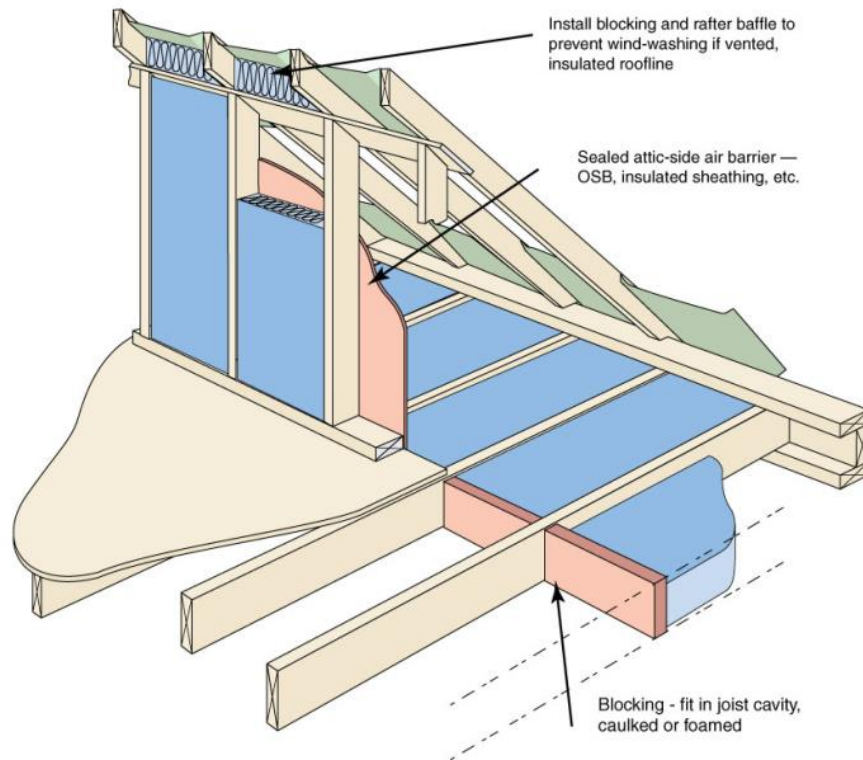

Figure 33: Attic knee wall blocking

Confirmation

- The EarthCraft Technical Advisor will visually confirm compliance of criteria at pre-drywall inspection.

BE 1.5 Seal penetrations through

Criteria

1. Foundation and exterior wall assemblies

Seal penetrations and joints in and between the foundation and exterior wall assemblies with blocking materials, foam and polyurethane caulk or the equivalent.

2. Top and bottom plate

Seal all holes in the top and bottom plates for plumbing, wiring, ductwork, and other purposes connecting conditioned and unconditioned (including exterior) areas, using appropriate sealant materials.

3. Band and rim joists

Seal all penetrations through the band and rim joist (between conditioned and exterior spaces and conditioned and garage spaces) including holes drilled for HVAC lines, plumbing lines, bathroom fans, exhaust fans and electrical lines using appropriate sealant.

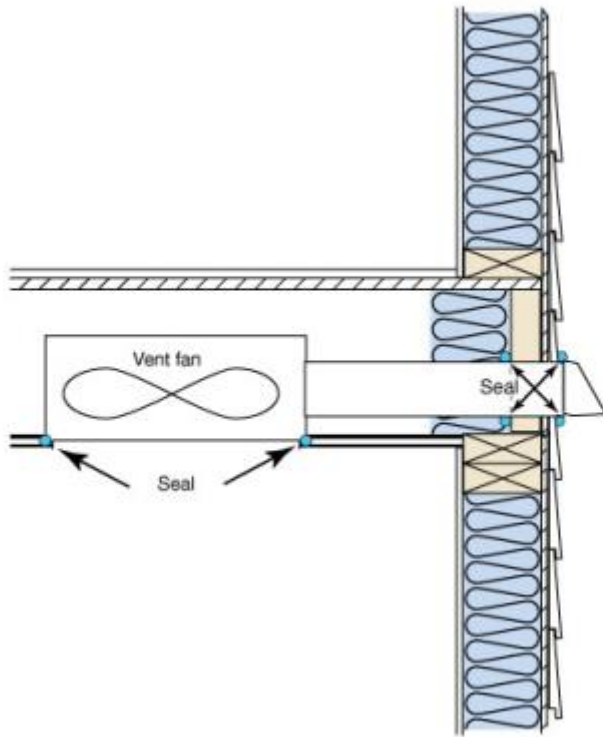

Figure 34: Bath fan vent sealed at rim joist

4. Insulated subfloor

Seal all penetrations (e.g. HVAC, plumbing and electrical) through insulated floor systems over unconditioned areas such as vented crawl spaces, unconditioned basements and garages.

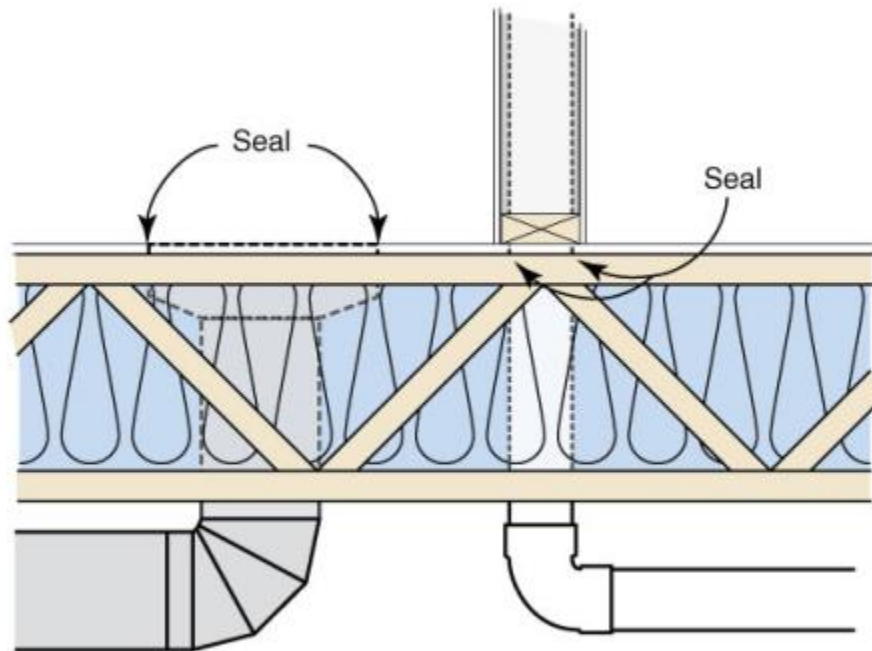

Figure 35: Air sealing at insulated subfloor

5. *Sheathing*

Seal penetrations in exterior wall sheathing including condensation lines, electrical outlets, water spigots, utility boxes and locations with broken or missing sheathing using appropriate materials and sealant.

6. *Walls and ceilings in attached garages*

Seal penetrations such as light fixtures, switches, electric boxes and plumbing pipe penetrations through wall and ceiling drywall in attached garage using appropriate sealant.

7. *All ceilings*

Seal penetrations (e.g., rough openings for can lights, ceiling fans and low voltage fixture penetrations) through insulated ceilings using appropriate sealant.

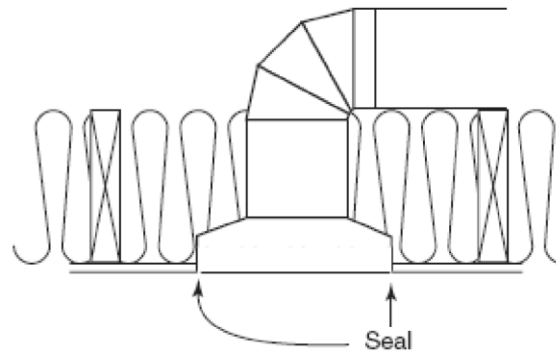

Figure 36: Air sealing at HVAC boot in insulated ceiling

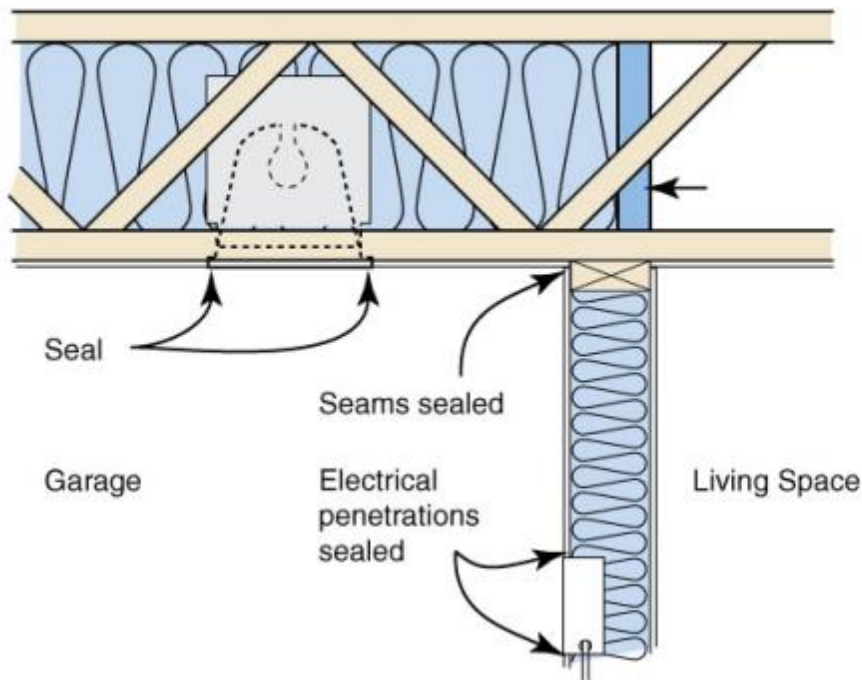

Figure 37: Air sealing at can light

Clarifications

Seal penetrations for flues and other heat-producing items with noncombustible sheet materials and high temperature sealant.

Confirmation

- The EarthCraft Technical Advisor will visually confirm compliance of criteria at pre-drywall and final inspections.

BE 1.6 Seal penetrations around

Criteria

1. Shower, sinks, toilets and tub drains

Block and seal subfloor penetrations for shower and tub drain using rigid sheeting and appropriate sealant. Plumbing penetrations in slab floors must be sealed with appropriate sealant.

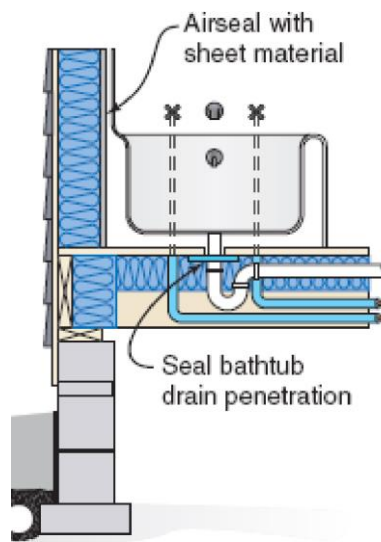

Figure 38: Air sealing at plumbing penetration in subfloor

2. HVAC supply and or drywall (floors, walls and ceilings)

return boots sealed to subfloor

Seal all HVAC supply and return boots to subfloor or drywall using appropriate sealant.

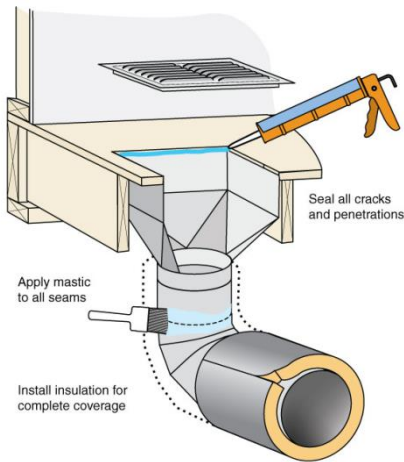
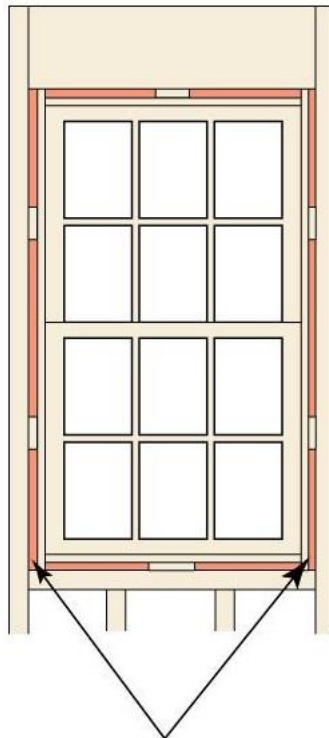

Figure 39: Sealing boot to subfloor

3. Window and door rough openings

Seal the space between the framing for window and door rough openings and the installed units using non-expanding or low-expanding spray foam sealant or closed-cell foam backer rod with appropriate sealant. Seal thresholds for exterior doors to the subfloor or slab.



Use backer rod or low expanding spray foam (appropriate for windows) to fill gaps between window/door and rough opening

Figure 40: Air sealing around window and door rough openings

4. *All drywall penetrations (common walls between attached units included)*

For all common walls between two dwelling units (e.g., duplexes, townhomes and multifamily), seal all penetrations through the top and bottom plate, and all drywall penetrations where permissible by fire code.

5. *Exhaust fans to drywall*

Seal all bathroom and kitchen exhaust fan housing units to drywall using appropriate sealant.

6. *Attic pull-down stairs, scuttle holes and kneewall doors*

Seal the space between the framing and attic pull-down stairs, scuttle holes or kneewall doors using non or low-expanding spray foam sealant or closed-cell foam backer rod with appropriate sealant.

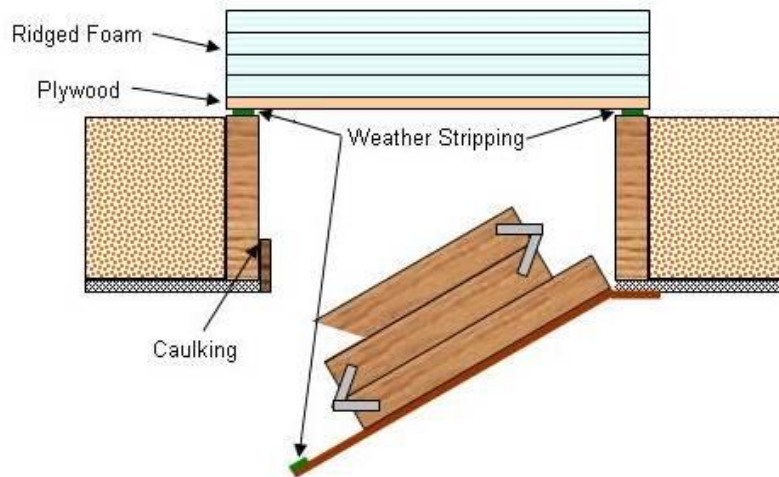

Figure 41: Attic pull-down stairs with foam board

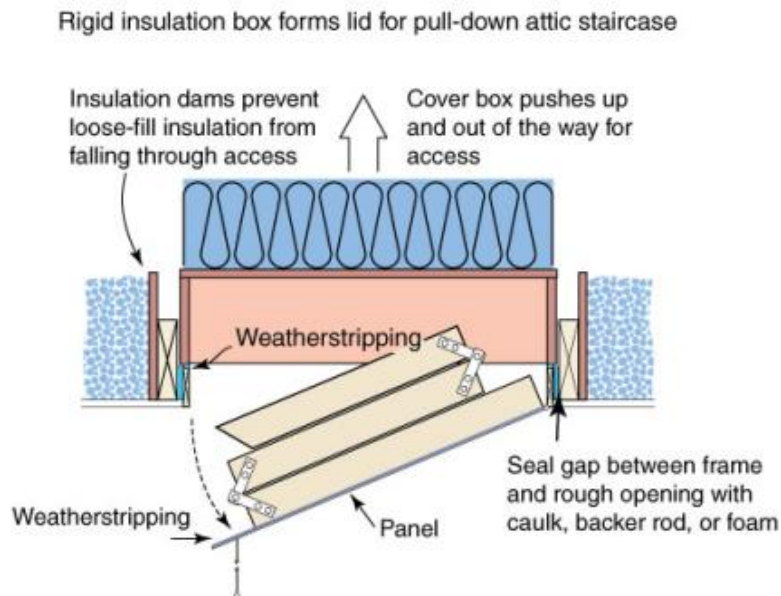

Figure 42: Attic pull-down stairs with batt insulation

7. Chases

Seal and insulate framed spaces that connect conditioned areas to unconditioned areas above and below the chase (including attics, unconditioned basements or vented crawl spaces) using sheet material and appropriate sealant. These areas include chases for plumbing, duct work, chimneys, and flues.

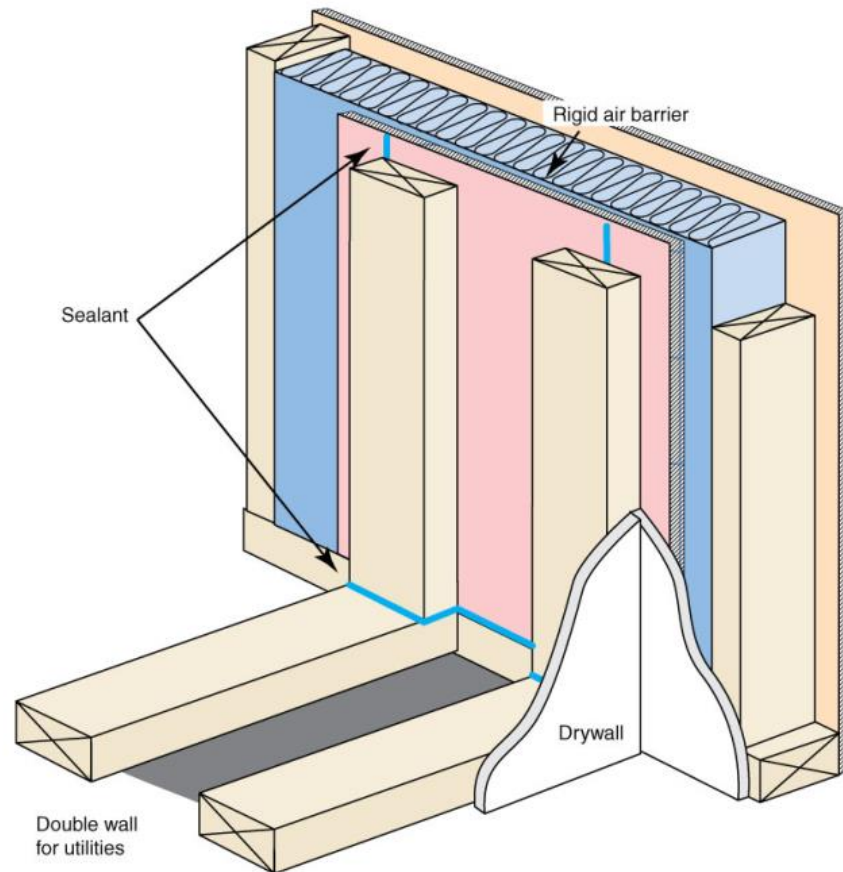

Figure 43: Rigid air barrier at chase on insulated wall

Clarifications

Cellulose, fiberglass or rockwool batt insulation is not acceptable as a sealant.

For chases with high temperature heat sources, use noncombustible sheet materials such as sheet metal and high temperature caulk to seal chase.

Confirmation

- The EarthCraft Technical Advisor will visually confirm compliance of criteria at pre-drywall and final inspections.

BE 1.7 Seal seams and gaps in:

Criteria

1. *Band joist sheathing*

Seal all seams in band joist sheathing separating conditioned and unconditioned spaces between conditioned floors. Band joist should be sealed to top plate, subfloor and at butt joints, or at exterior sheathing.

2. *Exterior wall sheathing*

Seal all gaps $\geq \frac{3}{8}$ " in exterior sheathing, such as seams between adjacent sheets, using appropriate sealant.

3. *All seams in SIPs*

Seal all seams between structurally insulated panels (SIPs) with appropriate sealant on the interior and exterior of the building envelope.

Confirmation

- The EarthCraft Technical Advisor will visually confirm compliance of criteria at pre-drywall inspection.

BE 1.8 Install rigid air barriers

Criteria

1. *Behind tubs and showers on insulated walls*

Install moisture resistant rigid interior air barriers behind tubs and showers on insulated walls before installing tub and shower assemblies.

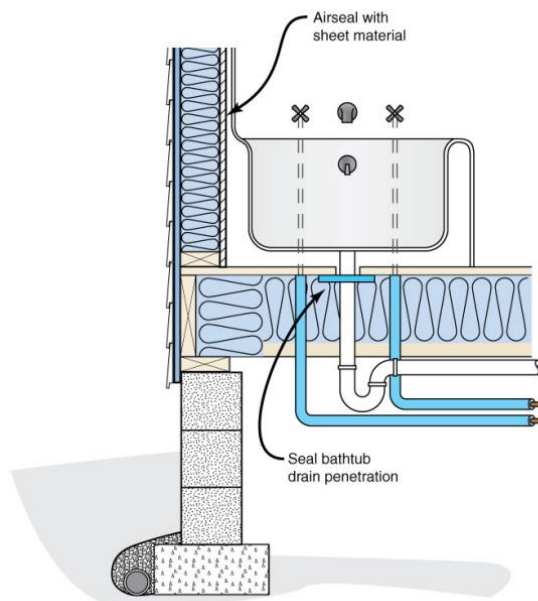

Figure 44: Air barrier behind tub

2. *At attic kneewall on attic-side (including skylight shafts)*

Install attic-side rigid air barrier to all kneewalls including skylight shafts. Seal seams of air barrier using appropriate sealant. Block and seal top and bottom of kneewall/skylight shaft stud cavity to encapsulate insulation.

3. At chases in contact with the building envelope (including fireplace chases)

All chases in contact with building envelope have air barrier applied to the interior of the chase where it meets the building envelope. All chase walls must be sealed using appropriate sealant (i.e., compliant with applicable fire code and manufacturer specifications).

4. Along staircases on insulated walls

Install rigid air barrier to the interior of all staircase walls adjoining unconditioned spaces (e.g., exterior walls, garages, or unconditioned attics). Seal seams of air barrier and penetrations through air barrier using appropriate sealant. Air barrier should include areas under enclosed landings and bottom stairs.

5. Along porch roofs

Seal and insulate all porch roofs at the vertical connection between the conditioned interior of the dwelling unit and the porch roof area.

6. At dropped ceiling/soffit

Seal and insulate dropped ceilings/soffits between conditioned areas and;

- interstitial spaces between floors
- and/or the attic using sheet material and appropriate sealant.

7. At all band joists above unit separation walls

Using appropriate sealant, seal and insulate all band joists above unit separation walls.

Clarifications

If cavity will be inaccessible for insulation installation after sheathing is applied, install insulation prior to enclosing the cavity. All fireplace chase walls must be sealed using appropriate sealant (i.e., compliant with applicable fire code and manufacturer specifications).

For projects Climate Zone 4, an internal air barrier must be installed on fireplace chase walls in addition to the exterior air barrier on fireplace chase walls.

Changes in ceiling height abutting unconditioned space of 18" or greater are considered attic kneewalls.

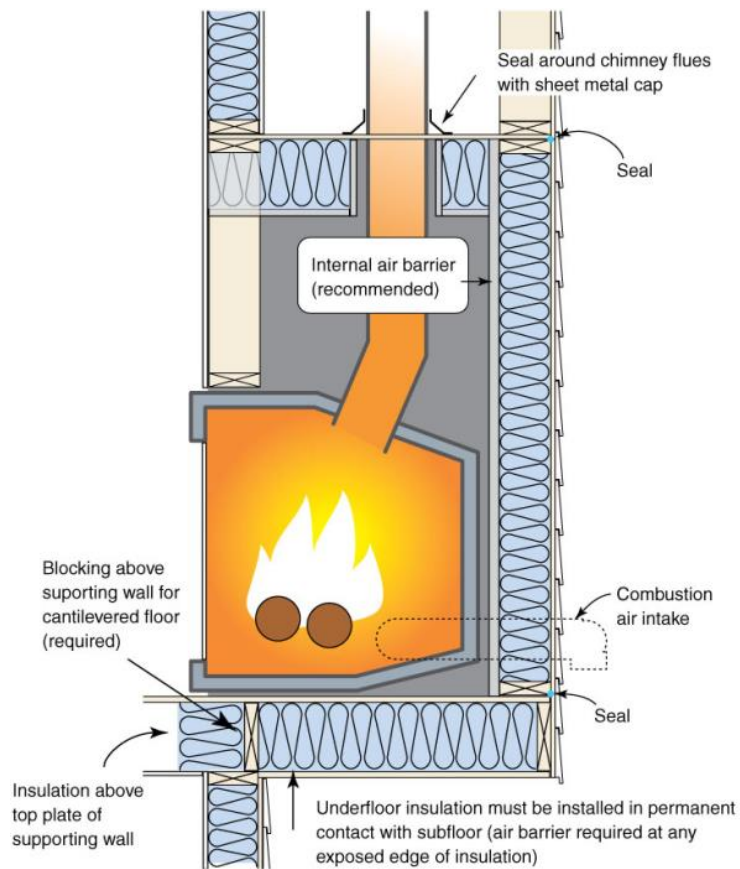

Figure 45: Insulated fireplace chase

Exemptions

For Climate Zones 2-3, projects with Grade I insulation installation and proper insulation support on fireplace walls, or other chases in contact with building envelope, are exempt from providing an internal air barrier along the fireplace chase walls. However, an air barrier must be installed along the exterior walls of the fireplace chase.

Example

There are two options for insulating and air sealing a fireplace chase on an exterior wall. The builder can either define the building envelope along the exterior walls of the fireplace chase or along the interior wall between conditioned space and the fireplace chase. All flues must be sealed to metal caps with appropriate sealant unless not allowed by local code.

Definitions

Attic knee walls, defined as a vertical or near vertical wall separating conditioned space from unconditioned attic space, could include skylight shaft walls or walls adjacent to porch roofs. Changes in ceiling height 18" or greater are considered attic knee walls.

Additional Resources

- [Rigid Air Barriers at Dropped Ceiling and Soffit - BASC](#)
- For information on the definition of Grade I insulation, see RESNET's Mortgage Industries National Home Energy Rating Standards at: <https://www.resnet.us/about/standards/>

Confirmation

- The EarthCraft Technical Advisor will visually confirm compliance of criteria at pre-drywall and final inspections.

BE 1.9 Install weather-stripping

Criteria

1. *At all exterior doors (if not included in door assembly)*

Install weather-stripping to all exterior doors that connect conditioned space to unconditioned spaces like the garage or outdoors.

2. *At attic knee wall doors, scuttle holes and pull-down stairs*

Weather-strip all knee wall doors, scuttle holes and pull-down stairs that connect conditioned space to unconditioned attic areas. Knee wall doors must latch to provide tight closure. Install weather stripping prior to setting hinges on pull-down stairs to ensure tight closure of assembly between conditioned space and attic.

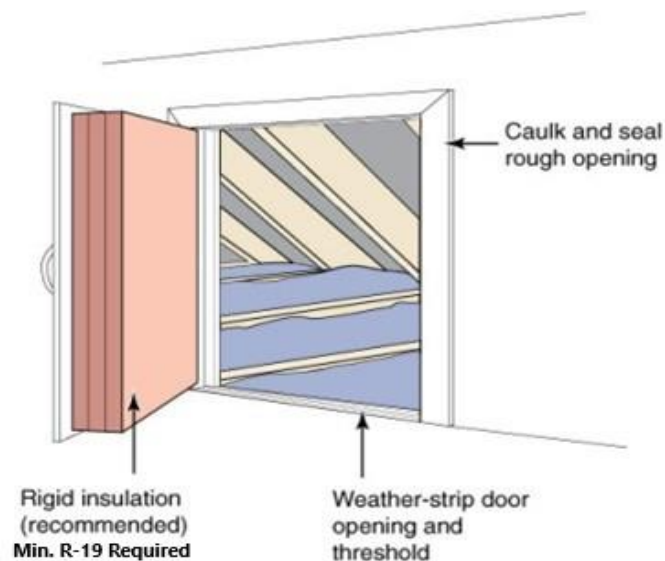

Figure 46: Kneewall door weather-stripping

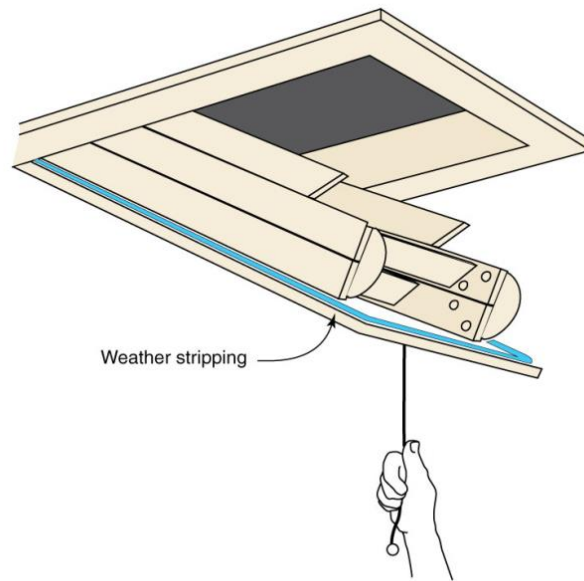

Figure 47: Pull-down stairs weather-stripping

Confirmation

- The EarthCraft Technical Advisor will visually confirm compliance of criteria at final inspection.

BE 1.10 All recessed can lights must be airtight, gasketed and IC-rated in insulated ceilings; in Climate Zone 4, insulate exterior surface of fixture to $\geq R-10$

Criteria

Recessed light fixtures in insulated ceilings with an unconditioned area above must be airtight and Insulation Contact (IC) rated and must be fully gasketed and sealed to the drywall. Recessed can lights in Climate Zone 4 must be insulated to a minimum of R-10 to minimize condensation potential.

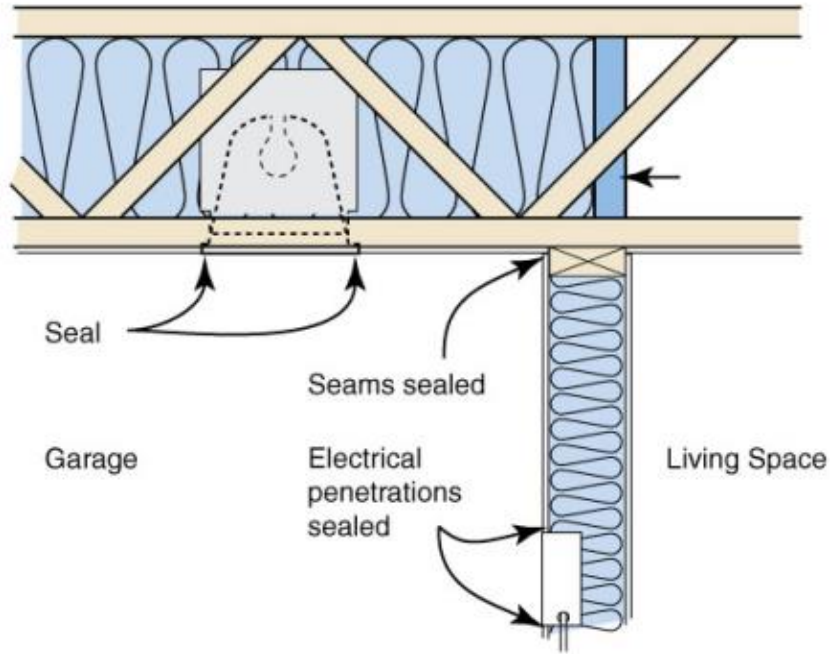

Figure 48: Can light installation

Confirmation

- The EarthCraft Technical Advisor will visually confirm compliance of criteria at pre-drywall inspection.

BE 1.11 Fire rated assemblies that do not use draft block in band areas must comply with Airtight Drywall Approach (ADA)

Criteria

Use an airtight drywall approach (ADA) to reduce air infiltration rates. Airtight drywall will qualify when a gasket or caulk is applied at all top plates at all exterior walls, interior partition walls, and unit separation walls. On bottom-floor or middle-floor units without gypcrete application, the gasket and caulk application will be required on all bottom plates at exterior walls, interior partition walls, and unit separation walls. All interior wall penetrations must be air sealed in walls and ceilings (including all fixtures and receptacle boxes).

Clarification:

Airtight drywall is required on projects that do not utilize fire blocking in the floor systems above tenant separation walls.

The ADA approach will reduce the unit envelope leakage in these circumstances in order to achieve the required envelope leakage goals. Projects that forego ADA in these locations and fail to reach the envelope leakage goals will not be eligible for ECMF certification.

See ECMF Common Obstacles Addendum for additional solutions for these locations.

Caulk or gaskets are acceptable applications, but liquid nails or other adhesives are not suitable for ADA applications.

Additional Resources

- [Info-401: Air Barriers—Airtight Drywall Approach](#)

Confirmation

- The EarthCraft Technical Advisor will visually confirm ADA compliance during drywall installation and at final inspections.

BE 1.12 Units adjacent to fire walls or CMU walls with an air gap assembly must follow Airtight Drywall Approach

Criteria

Use an airtight drywall approach (ADA) approach to reduce air infiltration rates. Airtight drywall will qualify when a gasket or caulk is applied at all top plates at all exterior walls, interior partition walls, and unit separation walls. On bottom-floor or middle-floor units without gypcrete application, the gasket and caulk application will be required on all bottom plates at exterior walls, interior partition walls, and unit separation walls. All interior wall penetrations must be air sealed in walls and ceilings (including all fixtures and receptacle boxes).

Clarifications

Airtight drywall is required on projects with units adjacent to fire walls or CMU walls with an air gap as part of the required assembly.

The ADA approach will reduce the unit envelope leakage in these circumstances in order to achieve the required envelope leakage goals. Projects that forego ATD in these locations and fail to reach the envelope leakage goals will not be eligible for ECMF certification.

Caulk or gaskets are acceptable applications, but liquid nails or other adhesives are not suitable for ATD applications.

Additional Resources:

- [Info-401: Air Barriers—Airtight Drywall Approach](#)

Confirmation

- The EarthCraft Technical Advisor will visually confirm ATD compliance during drywall installation and at final inspections.

BE 1.13 Seal top plate to drywall at the attic level

Criteria

Seal top plate to drywall at all interfaces with appropriate sealant (gaskets, foam, caulk, etc.) between unconditioned spaces and wall. Sealant may be applied from attic side to joints between drywall and top plate.

Seal drywall to top plate for walls separating the conditioned space from garage space.

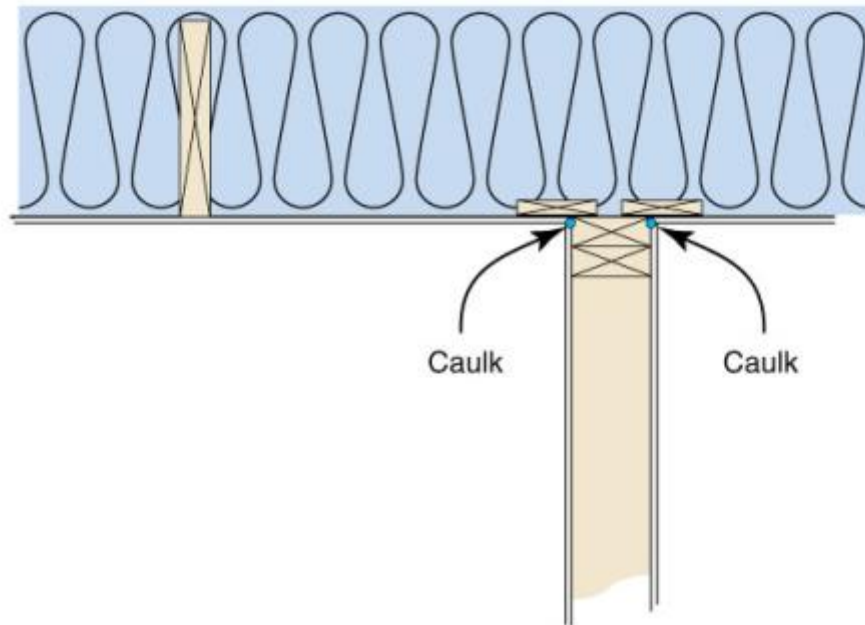

Figure 49: Top plate sealed

Clarifications

Construction adhesive is not permitted as sealant.

Confirmation

- The EarthCraft Technical Advisor will visually confirm compliance of criteria at final inspection.

BE 1.14 Comply with Airtight Drywall approach

Criteria

Use an airtight drywall (ADA) approach to reduce air infiltration rates. Airtight drywall will qualify when a gasket or caulk is applied at all top plates at all exterior walls, interior partition walls, and unit separation walls. On bottom-floor or middle-floor units without gypcrete application, the gasket and caulk application will be required on all bottom plates at exterior walls, interior partition walls, and unit separation walls. All interior wall penetrations must be air sealed in walls and ceilings (including all fixtures and receptacle boxes).

Required:

Airtight drywall is required on projects that do not utilize fire blocking in the floor systems above tenant separation walls and in dwelling units adjacent to fire walls or CMU walls with an air gap as part of the required assembly.

The ADA approach will reduce the unit envelope leakage in these circumstances in order to achieve the required envelope leakage goals (BE 2: Air Changes Per Hour). Projects that choose to forego ADA in these locations and fail to reach the envelope leakage goals will not be eligible for ECMF certification.

Clarification

Caulk or gaskets are acceptable applications, but liquid nails or other adhesives are not suitable for ADA applications.

Confirmation

- The EarthCraft Technical Advisor will visually confirm ADA compliance during drywall installation and at final inspections.

BE 1.15 Gypcrete on all framed floors separating unit envelopes

Criteria

Apply gypcrete in space between tenant separation walls or any dead cavities existing between units or between units and common areas.

Clarification

If isolation strip installed between gypcrete and bottom plate and/or gypcrete and drywall, additional air sealing may be necessary at the floor to wall transition after gypcrete installed.

Confirmation

- The EarthCraft Technical Advisor will visually confirm at pre-drywall inspections.

BE 1.16 Two-pour application of gypcrete include areas blocked by drywall

Criteria

Apply an additional application of gypcrete in areas otherwise blocked by drywall. Such areas will include space beneath tubs, chases, dead spaces between adjacent units and units and common areas.

Clarification

If isolation strip installed between gypcrete and bottom plate and/or gypcrete and drywall, additional air sealing may be necessary at the floor to wall transition after gypcrete installed.

Confirmation

- The EarthCraft Technical Advisor will visually confirm at pre-drywall inspections.

BE 1.17 Firewalls/party walls that eliminate air gap (UL-U370 or equivalent)

Criteria

Approved assemblies that do not utilize an air gap will qualify.

Confirmation

- Project team must supply plan details on the qualifying system.
- The EarthCraft Technical Advisor will visually confirm at pre-drywall inspections.

Blower door test (BE 2)

Criteria

A blower door test is required for all EarthCraft projects. Various levels of tightness are needed for each level of certification.

Clarifications

Floor area must equal conditioned floor area used for the confirmed HERS energy model.

Example

The following diagram represents a two-story home on a slab with a flat ceiling and ventilated attic. The home has an attached 20'x20' garage.

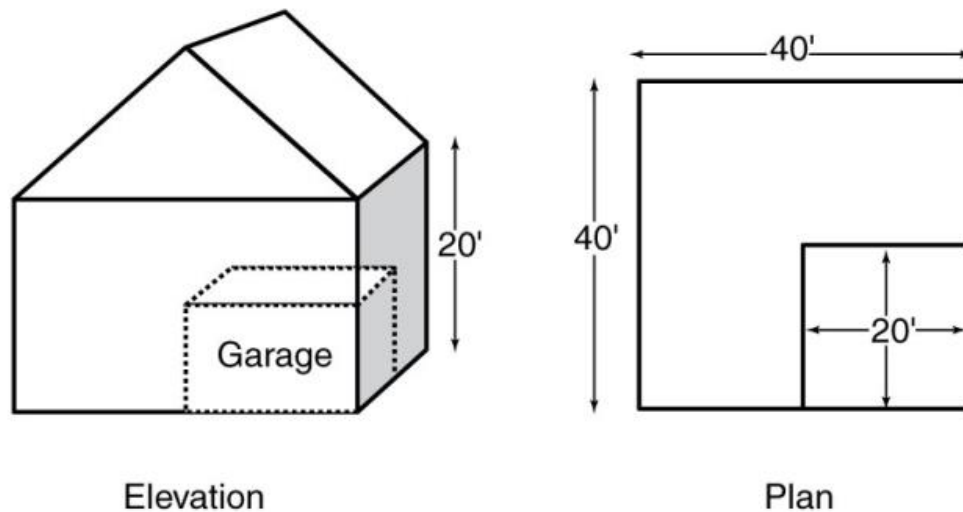

Figure 50: Sample floor plan

$$\text{CALCULATION: } \text{cfm}_{50} \cdot 60 / \text{Volume} = \text{ACH}_{50}$$

BLOWER DOOR TEST RESULT: 2,000 cfm at 50 Pa pressure (2,000 cfm_{50})

For the above referenced home VOLUME = 1200 ft. sq. * 10 + 1600 ft. sq. * 10 = 28,000 cu. Ft.

$$2,000 \text{ cfm}_{50} \cdot 60 / 28,000 \text{ cu. Ft.} = 4.28 \text{ ACH}_{50}$$

Resources

[BSI-108: Are We Sealing The Right Walls In Buildings?](#)

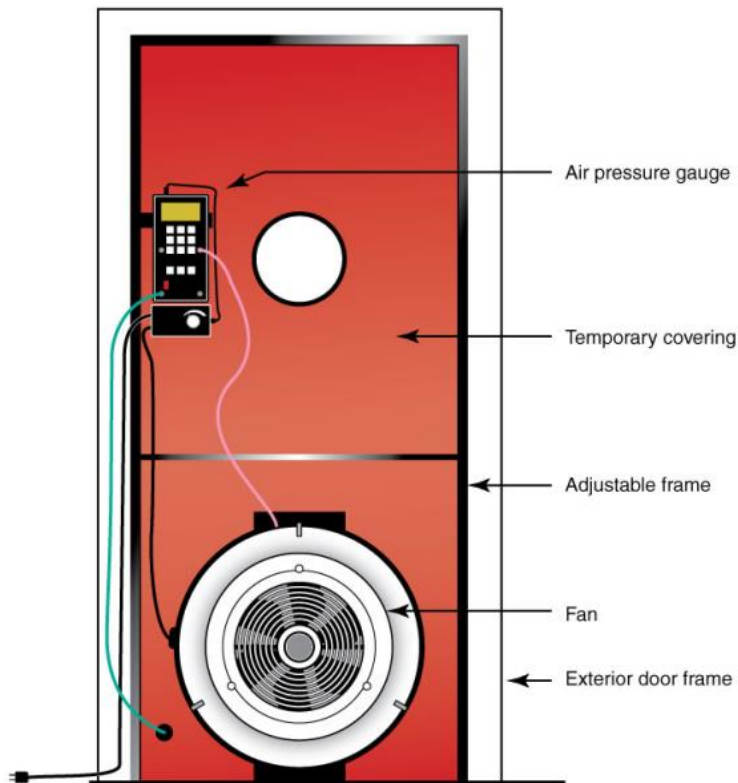

Figure 51: Blower door

Confirmation

- The EarthCraft Technical Advisor will diagnostically test compliance of criteria at the final inspection.

BE 2.0 Air Changes per Hour ≤ 5 ACH₅₀

Criteria

Dwelling Units will be tested individually. The envelope infiltration rate must be ≤ 5 ACH₅₀ to meet minimum certification requirements. Adaptive Reuse projects must be < 7 ACH₅₀.

Additional Resources

- [Field Testing of Compartmentalization Methods for Multifamily Construction](#)
- [BSI-108: Are We Sealing The Right Walls In Buildings?](#)
- [ENERGY STAR Thermal Enclosure Guidebook](#)

Confirmation

- The EarthCraft Technical Advisor will diagnostically test compliance of criteria at the final inspection.

BE 2.1 Air Changes per Hour ≤ 4 ACH₅₀

Criteria

The envelope infiltration rate must be ≤ 4 ACH₅₀.

Confirmation

- The EarthCraft Technical Advisor will diagnostically test compliance of criteria at the final inspection.

BE 2.2 Air Changes per Hour ≤ 3 ACH₅₀

Criteria

The envelope infiltration rate must be ≤ 3 ACH₅₀.

Confirmation

- The EarthCraft Technical Advisor will diagnostically test compliance of criteria at the final inspection.

BE 3.0 Floors

Criteria

1. *Framed* $\geq R-19$

Insulate framed floor over enclosed unconditioned spaces to R-19 or greater.

Insulation must be in permanent contact with subfloor, or a fully aligned air barrier on the exterior side of the conditioned space provided that the perimeter rim and band joists of the floor cavity are also sealed and insulated to comply with the insulation and air sealing requirements for walls.

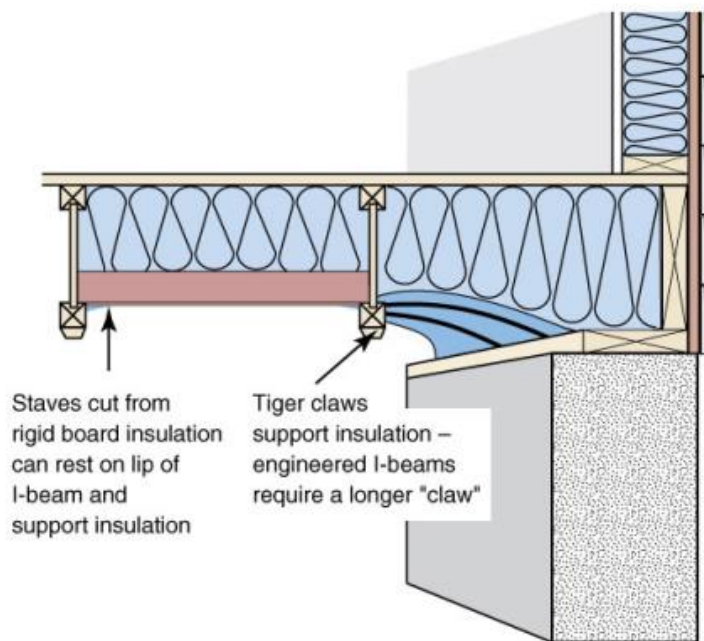

Figure 52: Floor insulation supports

2. *Cantilevered/over exterior spaces* $\geq R-30$

Block between joists and insulate all floors with conditioned space over ambient areas to R-30 or greater. Blocking between joists is required when joists cross from unconditioned spaces to conditioned spaces.

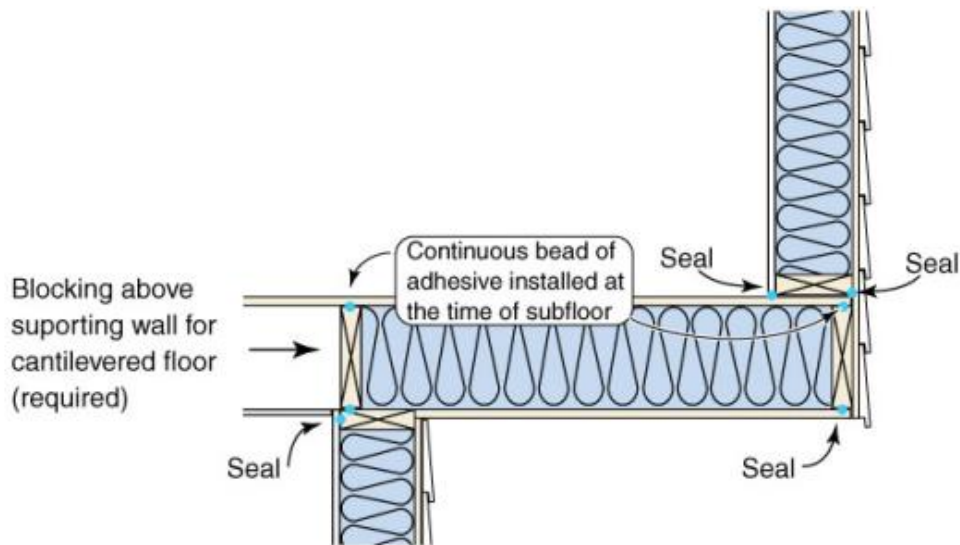

Figure 53: Cantilevered floor insulation

3. Podium/elevated slabs \geq R-19

Insulate podiums or elevated slabs over unconditioned spaces to R-19 or greater.

Insulation must be in permanent contact with subfloor, or a fully aligned air barrier on the exterior side of the conditioned space provided that the perimeter rim and band joists of the floor cavity are also sealed and insulated to comply with the insulation and air sealing requirements for walls.

Clarifications

Framed floors over basement/crawl space require insulation only if basement/crawl space is outside of building envelope.

If insulating a steel joist floor, R-6 continuous insulation must be installed in addition to floor insulation listed above.

Enclosed unconditioned spaces typically include vented crawl space, unconditioned basement, garage, etc.

Conditioned spaces over ambient areas typically include floors over carports, cantilevered floors, etc.

Additional Resources

- [BSI-059: Slab Happy - Building Science Corporation](#)

Confirmation

The EarthCraft Technical Advisor will visually confirm compliance with criteria at pre-drywall and final inspections.

BE 3.1 Walls

Criteria

1. *Exterior walls and band joist \geq R-15 Cavity Insulation*

Install insulation on all exterior walls \geq R-15, including air-barriers behind showers and tubs on exterior walls. Cut batts in narrow cavities and around plumbing and wiring to fit per manufacturer's specifications or fill narrow cavities with sprayed/blown insulation.

2. *Elevator walls adjacent to dwelling units \geq R-13*

Install insulation on elevator walls adjacent to dwelling units \geq R-13. Cut batts in narrow cavities and around plumbing and wiring to fit per manufacturer's specifications or fill narrow cavities with sprayed/blown insulation.

3. *Foundation walls \geq R-10 continuous or \geq R-13 cavity*

Insulate foundation walls in Climate Zone 4 to minimum R-10 continuous or R-13 cavity insulation.

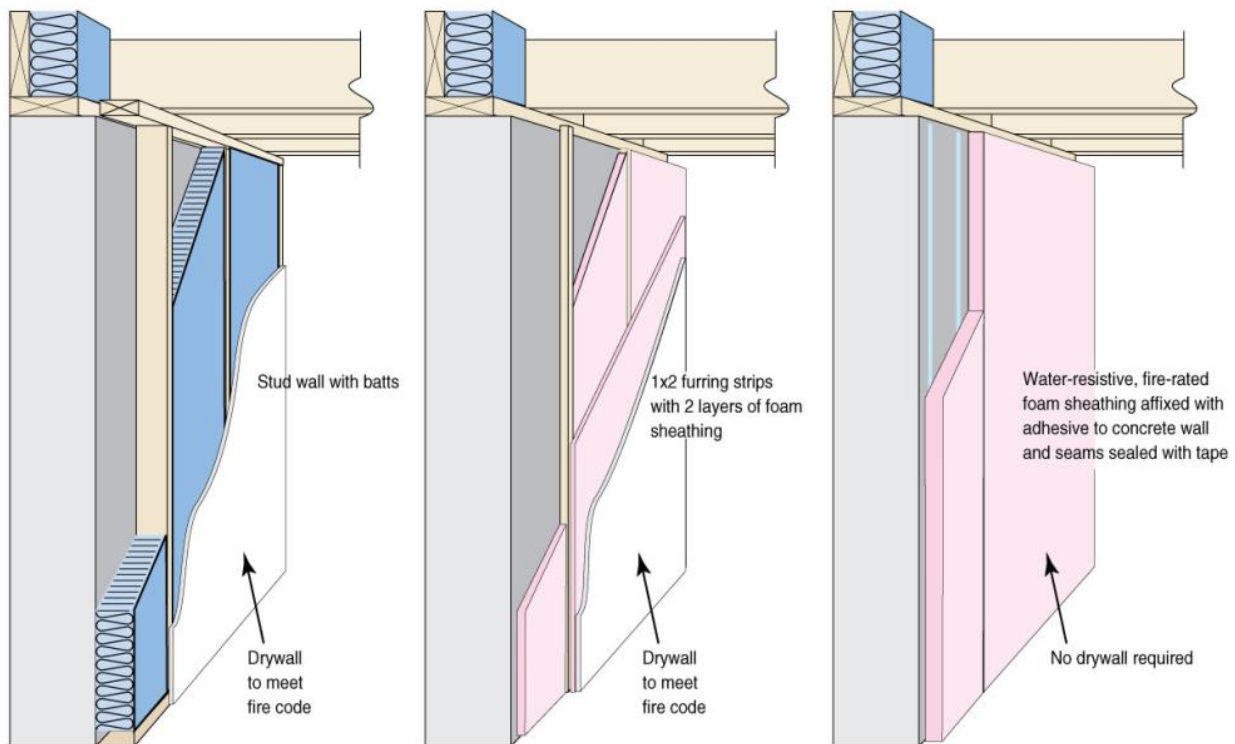

Figure 54: Foundation wall insulation

Clarifications

Garage walls are considered exterior walls.

Foundation walls require insulation if inside building thermal envelope.

Insulation must be in permanent contact with foundation wall.

Confirmation

- The EarthCraft Technical Advisor will visually confirm compliance of criteria at pre-drywall and final inspections.

BE 3.2 Ceilings/Roof

Criteria

1. *Vented: Climate Zone 4 $\geq R-49$*

Install insulation $\geq R-49$ in Climate Zone 4. Continue full depth of insulation over perimeter top plates.

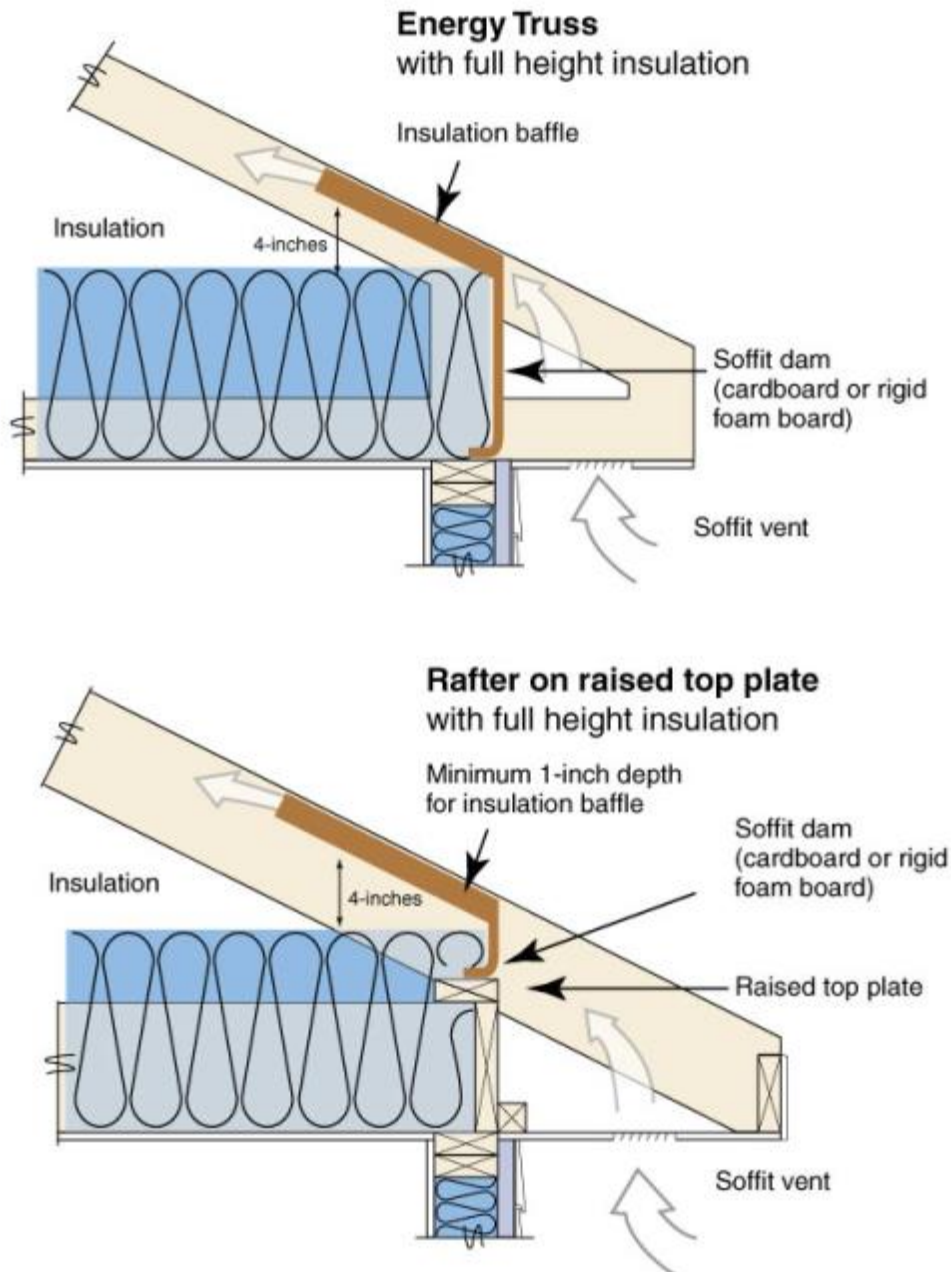

Figure 55: Full insulation over top plate

2. *Continuous Roof Deck: Climate Zone 4 $\geq R-30$*

For roofs with continuous insulation located entirely above deck, insulate to $\geq R-30$

3. *Cathedral: Climate Zone 4 $\geq R-38$ Cavity*

In sloped ceilings with no attic above, install cavity insulation greater than or equal to R-38 in Climate Zone 4.

Clarifications

Flat ceiling insulation not installed to full depth (e.g., under attic platforms, over wall top plates at eaves, etc.) must be modeled at actual installed R-value but may not be modeled or installed less than R-30, and no more than 500 sq ft or 20% of the total insulated ceiling area, whichever is less, may be less than R-49 in Climate Zone 4.

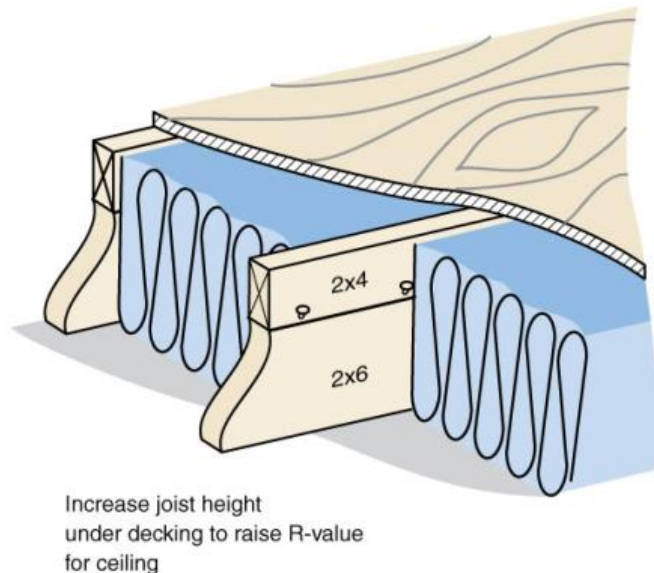

Figure 56: Raised joist to accommodate for insulation under attic platform

Sloped ceilings with ambient above (e.g., cathedral ceilings) are not addressed under these criteria and should be addressed as part of the following EarthCraft criteria: “Insulate roofline \geq R-30”.

Confirmation

- The EarthCraft Technical Advisor will visually confirm compliance of criteria at pre-drywall and final inspections.

BE 3.3 Attic/Roof

Criteria

1. *Install wind baffles at eaves in every vented bay, or equivalent air barrier at edge of ceiling*

Install wind baffles or blocking at eaves to prevent wind washing over insulation. Include a baffle in every bay or a tabbed baffle in each bay with a soffit vent that will also prevent wind washing of insulation in adjacent bays.

2. *Energy heel trusses or raised top plates*

Install energy heel trusses or raised top plates to ensure full depth of attic insulation above exterior wall top plates. Depth of insulation above top plate may be traded to R-21 when allowed by code and reflected in the energy model.

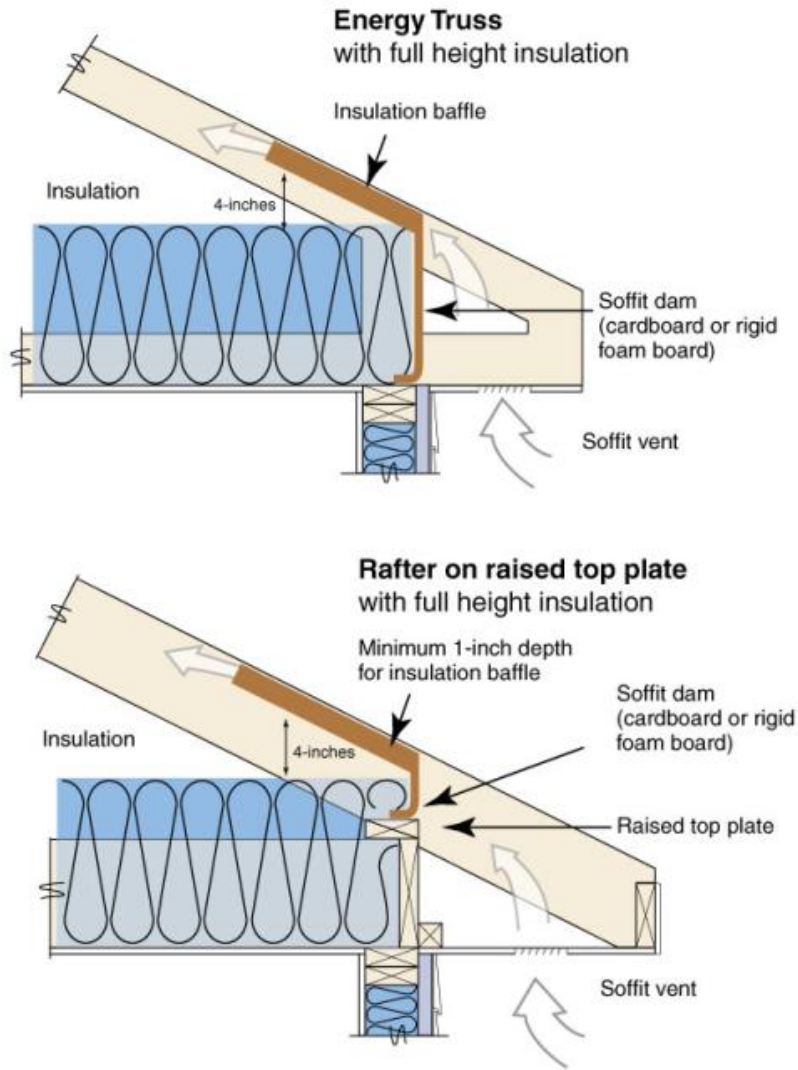

Figure 57: Energy heel truss (top), raised top plate (bottom)

3. Attic platforms allow for full-depth insulation below

Raise attic platforms to allow for full depth of insulation below meeting minimum flat ceiling R-value requirement. Access to equipment or storage with attic platform must be maintained without compressing insulation.

Confirmation

- The EarthCraft Technical Advisor will visually confirm compliance of criteria at pre-drywall inspection.

BE 3.4 Attic kneewall

Criteria

1. *Doors: Climate Zone 4 \geq R-19*

Insulate doors separating conditioned space from unconditioned attic spaces to R-19 or greater in Climate Zone 4. Attic kneewall doors must allow for full depth of minimum R-value insulation when opened preventing damage of insulation over time.

2. *Insulation and attic side air barrier: Climate Zone 4 \geq R-19*

Install rigid attic side air barrier (e.g., foam board, plywood, OSB) along all kneewalls separating conditioned space from unconditioned attic space. Air barrier must align with bottom and top plates of attic kneewall to provide full insulation encapsulation on all 6 sides. Insulate kneewalls separating conditioned space from unconditioned attic space to R-19 or greater in Climate Zone 4.

Insulation must be in contact with attic side air barrier.

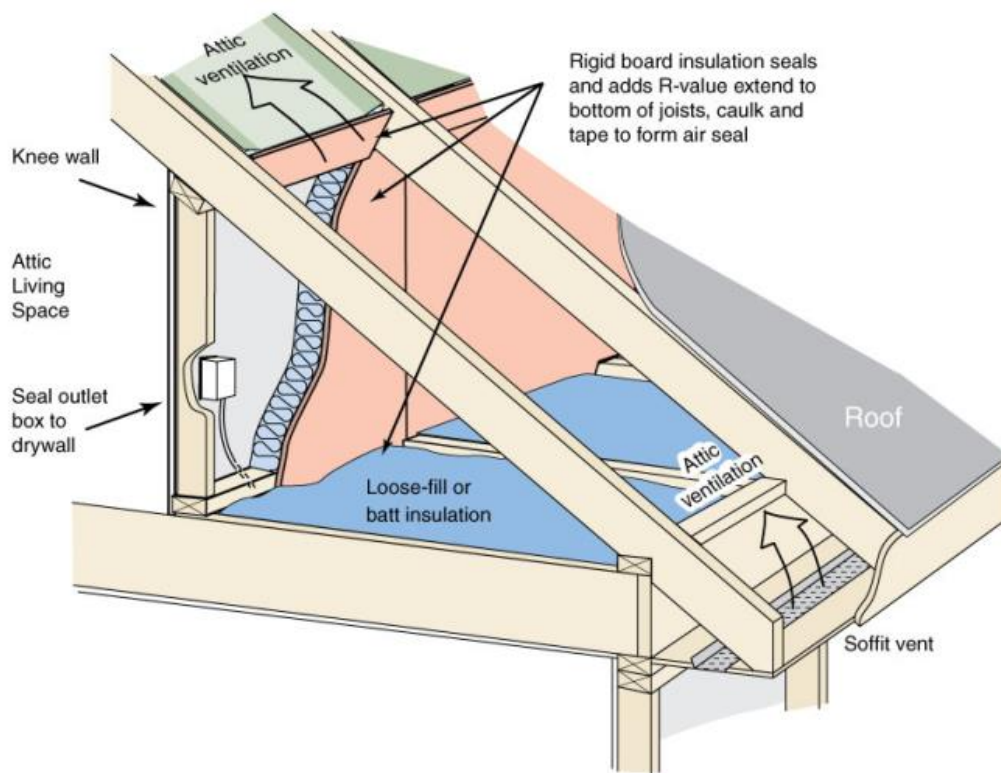

Figure 58: Attic kneewall insulation and blocking

Example

A 2x4 wall assembly with R-13 batts and R-5 continuous rigid insulation, or a 2x6 wall assembly with R-19 batts.

Confirmation

- The EarthCraft Technical Advisor will visually confirm compliance of criteria at pre-drywall and final inspections.

BE 3.5 Attic pull-down/scuttle hole: Climate Zone 4 \geq R-49

Criteria

Install pull-down attic stairs separating conditioned space from unconditioned attic space with an insulated box or other cover equal to or greater than R-49 in Climate Zone 4.

Insulate scuttle holes separating conditioned space from unconditioned attic space with batt insulation or rigid foam insulation equal to or greater than R-49 in Climate Zone 4.

Clarifications

Insulation must completely cover rough opening of pull-down stairs. Compressed batts are not acceptable.

Confirmation

- The EarthCraft Technical Advisor will visually confirm compliance of criteria at final inspection.

BE 3.6 When installing loose-fill attic insulation, install card and rulers

Criteria

Install attic rulers facing the attic entrance every 300 sq ft to verify insulation depth. Post in the attic written documentation (an “attic card”) specifying the insulation type, coverage area, and R-value.

Confirmation

- The EarthCraft Technical Advisor will visually confirm compliance of criteria at final inspection.

BE 3.7 Steel-framed buildings require thermal break \geq R-7.5

Criteria

All steel-framed buildings must be insulated with continuous exterior insulation greater than or equal to R-7.5

Clarification

If points are attempted for BE 3.16, R-7.5 will be subtracted from the R value of the installed continuous insulation to determine compliance with BE 3.16.

Confirmation

- The EarthCraft Technical Advisor will visually confirm compliance with criteria at final inspection.

BE 3.8 Grade II insulation quality at all building envelope locations

Criteria

Install insulation per manufacturer’s recommendations to achieve quality Grade II as specified by criteria set forth by RESNET. All insulation must meet or exceed Grade II installation quality regardless of location in building.

Additional Resources

- [Insulation Grading - Building America Solution Center](#) | [Insulation Grading - Building America Solution Center](#) (Permalink)



Figure 59: RESNET Protocol for Fiberglass Batt Insulation Grading

Confirmation

- The EarthCraft Technical Advisor will visually confirm compliance with criteria at pre-drywall inspections.

BE 3.9 Slab edge insulation: Climate Zone 4 \geq R-10

Criteria

Install exterior slab insulation, Climate Zone 4 \geq R-10 (heated slabs \geq R-15) so that it extends to the top of the slab. Slab edge insulation must extend to the bottom of the footing or 2' whichever is less.

Clarifications

Where an insulated wall separates a garage, patio, porch or other unconditioned space from the conditioned space of the house, slab insulation shall also be installed at this interface to provide a thermal break between the conditioned and unconditioned slab, unless the slab is post-tensioned with integrated garage or porch foundations, in which case it may be omitted at this location only.

For exterior slab edge insulation, such as for monolithic slabs, install insulation with approved membranes, such as EPDM-type membranes, to protect against termites.

Non-monolithic slabs may use rigid insulation between the stem wall and the poured (floating) slab, using the protective membrane as a termite flashing and as a capillary break.

If the top edge of the insulation is installed between the exterior wall and the edge of the interior slab, it shall be permitted to be cut at a 45-degree angle away from the exterior wall.

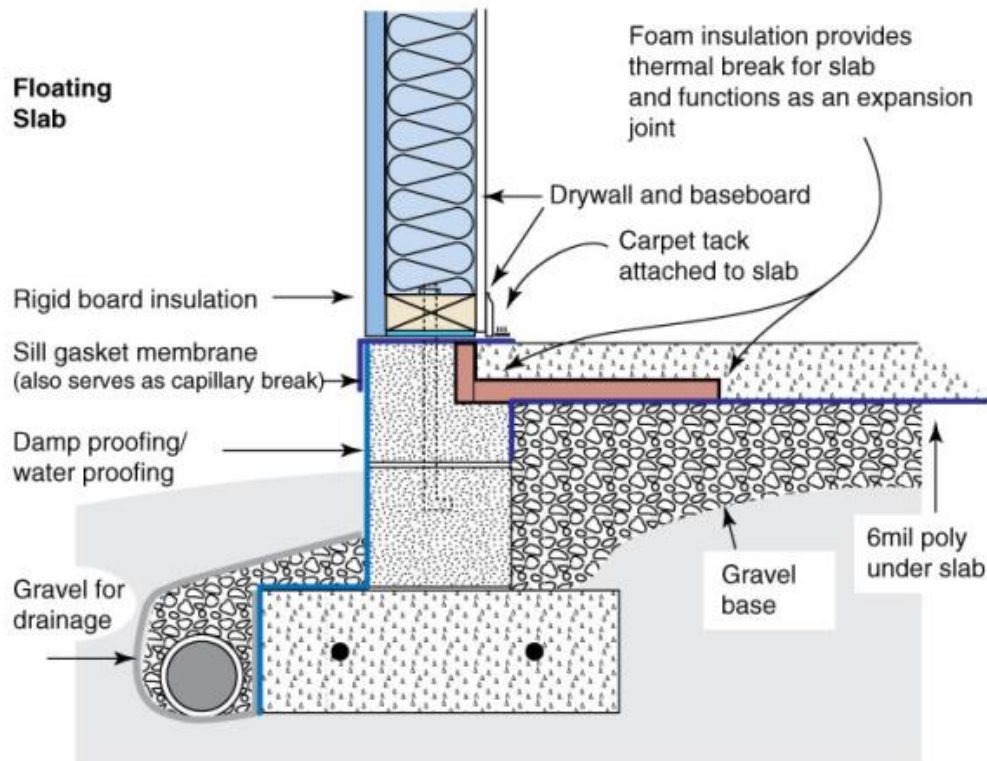

Figure 60: Slab edge insulation for floating slab

Exemptions

Slab edge insulation is not required in jurisdictions designated by the local code official as having a very heavy termite infestation.

Slabs greater than 12" below grade as measured from the top of the slab are not required to have insulation.

Confirmation

- The builder will illustrate compliance through photo documentation submitted to the EarthCraft Technical Advisor at pre-drywall.
- The EarthCraft Technical Advisor will review photo documentation provided by the builder at pre-drywall.

BE 3.10 Insulation installation quality (floors, walls and ceilings)

Criteria

A. Grade I

Install insulation per manufacturer's recommendations to achieve insulation quality Grade I as specified by criteria set forth by RESNET for all floors, walls and ceilings.

B. Grade II with insulated sheathing $\geq R-3$ (100%)

Install insulation with insulated sheathing $\geq R-3$ on 100% of the building per manufacturer's recommendations to achieve insulation quality Grade II as specified by criteria set forth by RESNET for all floors, walls, and ceilings. For steel-framed walls, exterior insulation must be greater than R-10.

Clarifications

Floors, walls, and ceilings with conditioned space on both sides do not need to meet this to earn points.

Additional Resources

- [Insulation Grading – Building America Solution Center](#) | [Insulation Grading – Building America Solution Center](#) (Permalink)

Confirmation

- The EarthCraft Technical Advisor will visually confirm compliance with criteria at pre-drywall inspection.

BE 3.11 Corners \geq R-6

Criteria

Insulate the intersecting corner of two walls separating conditioned and unconditioned space to greater than or equal to R-6 so that insulation is continuous in the external wall.

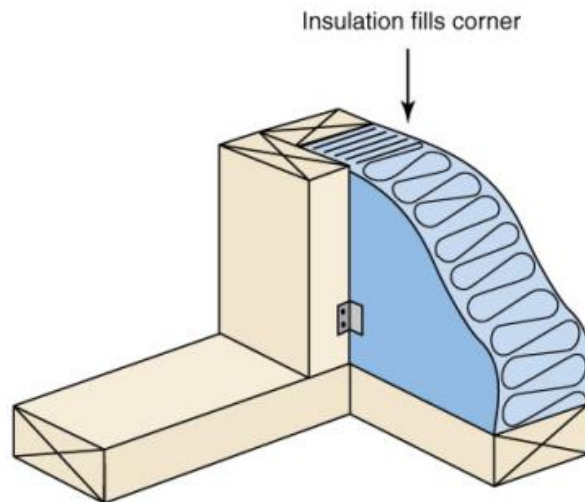

Figure 61: Insulated corner

Clarifications

The “California corner” (i.e., two-stud corner with drywall clips or deadwood nails) is one method of meeting this requirement.

The corner must be fully insulated to achieve the intent; therefore, corners with more than three studs are not permitted.

Confirmation

- The EarthCraft Technical Advisor will visually confirm compliance with criteria at pre-drywall inspection.

BE 3.12 Headers \geq R-3

Criteria

Insulate all headers on walls separating conditioned and unconditioned space to greater than or equal to R-3.

Insulated headers

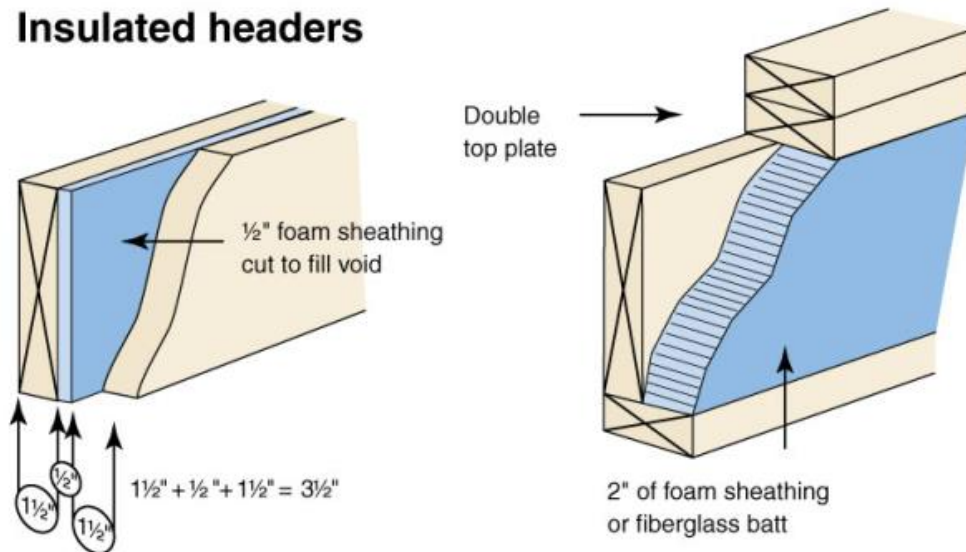

Figure 62: Insulated headers

Clarifications

The R-value requirement refers to the insulation manufacturer's nominal insulation value.

Examples

Methods include substituting 1/2" plywood spacer with 1/2" rigid foam insulation, boxed headers with cavity insulation, pre-manufactured insulated headers, SIP headers and continuous rigid insulation sheathing.

Exemptions

Headers on exterior walls where the structural engineered framing layout indicates that full-depth solid headers are the only acceptable option are exempt from being insulated. No points will be earned if exempted.

Confirmation

- The EarthCraft Technical Advisor will visually confirm compliance with criteria at pre-drywall inspection.

BE 3.13 Fiberglass batts are unfaced/friction fit

Criteria

Apply unfaced batt insulation to all exterior wall assemblies and use friction fit installation techniques between studs and joists.

Clarification

Blown-in insulation also qualifies.

Confirmation

- The EarthCraft Technical Advisor will visually confirm compliance with criteria at pre-drywall inspection.

BE 3.14 Insulate with foam

Criteria

1. Exterior walls including band area
2. Floor system over crawl space or basement

Clarifications

Spray foam insulation must qualify as a full air barrier product in order to achieve credit. Rigid foam products can only gain credit for #2.

Floors over parking garages may also qualify for this item.

Confirmation

- Project team will submit product specifications showing air barrier qualifications.
- The EarthCraft Technical Advisor will visually confirm compliance with criteria at pre-drywall inspection.

BE 3.15 Walls

Criteria

1. Seal and insulate crawl space walls:
Climate Zone 4 $\geq R-10$ continuous

Permanently install insulation to crawl space walls and extend downward from the termite inspection strip to grade.

Provide a 3" inspection strip immediately below the floor joists to allow inspection for termites. (The inspection strip may be insulated with a removable section of insulation but is not required to be insulated.)

An additional strategy required to meet this credit intent is described in DU 1.11. If installed, crawl space must be closed.

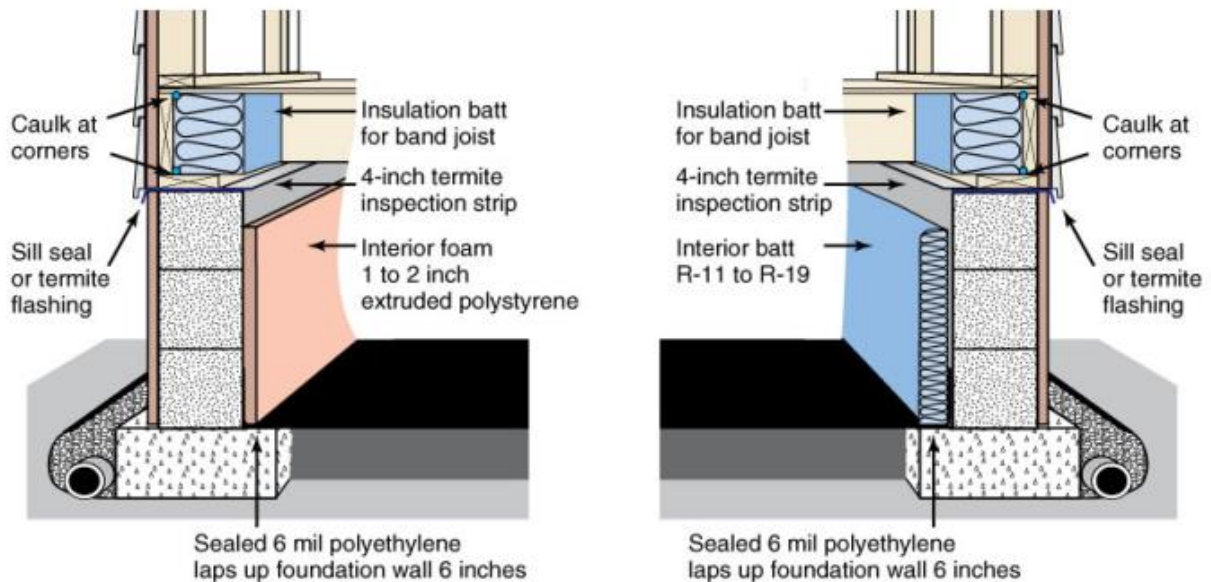

Figure 63: Enclosed crawl space with insulation along walls

2. Insulate unfinished basement walls instead of ceiling

Insulate basement walls instead of floor-joint cavities over basement. Basement walls more than half below grade must be either R-13 cavity insulation or R-5 continuous insulation in Climate Zones 2 and 3 or R-10 continuous in Climate Zone 4. Use code-approved materials. Above-grade basement and foundation walls must be insulated to meet minimum wood or mass wall requirements (e.g., R-13 cavity insulation for wood frame wall).

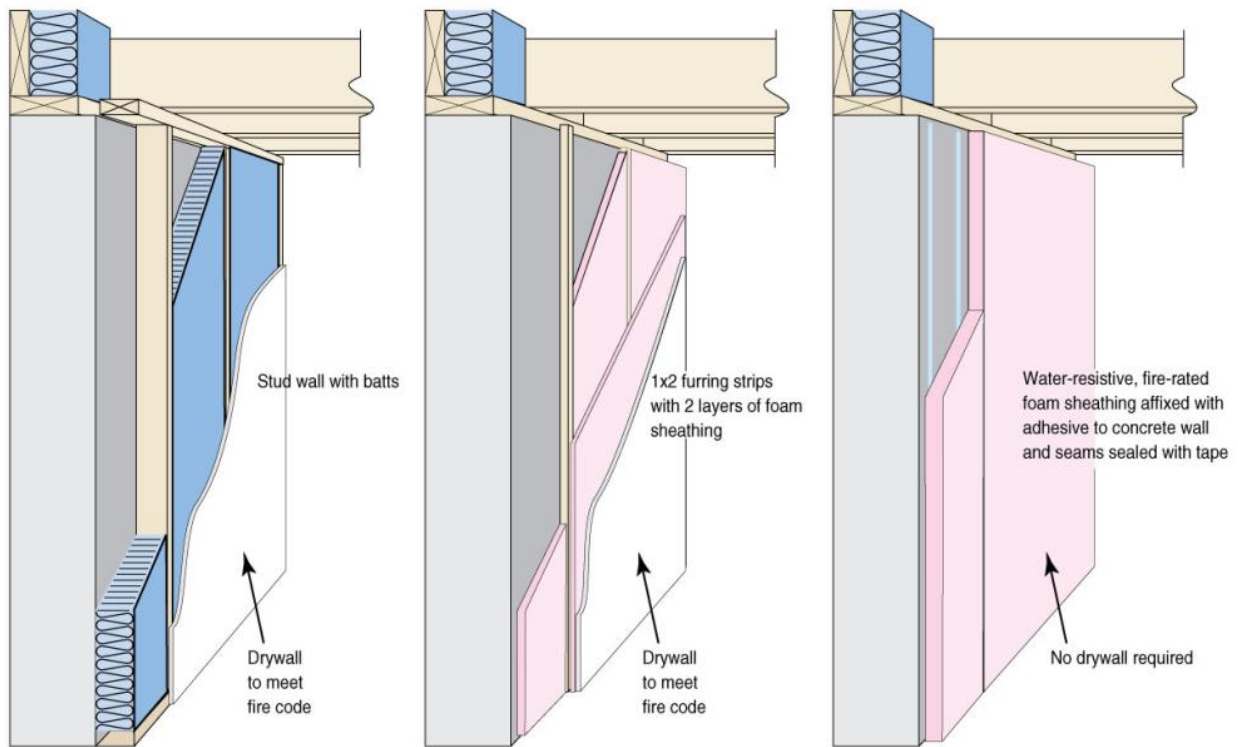

Figure 64: Basement wall insulation

3. Insulate basement walls with continuous insulation

Insulate below-grade basement walls with R-5 or greater continuous insulation in Climate Zones 2 and 3 or R-10 or greater continuous insulation in Climate Zone 4.

4. Insulate exterior walls and band joist $\geq R-19$

Install wall stud cavity insulation to R-19 or greater in a minimum of 90% of all exterior framed walls and band joists adjacent to unconditioned spaces. Insulation must be installed according to manufacturer's specifications and meet RESNET Grade II criteria or better.

Insulate all band joist areas between conditioned floors using R-19 insulation. Insulation must be installed using manufacturer recommendation for permanent alignment with band joist.

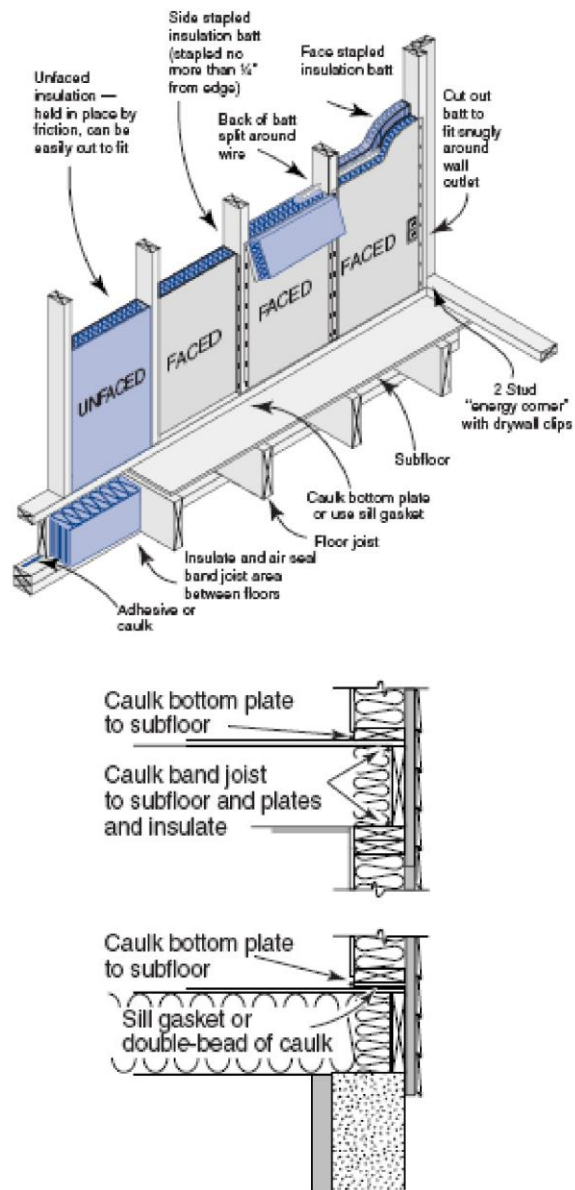

Figure 65: Exterior Wall and Band Joist Insulation

5. Insulate with spray foam insulation: Flash and Batt insulation including band area

Criteria

Spray foam insulation must qualify as a full air barrier product in order to achieve credit

6. Insulate exterior walls and band joist $\geq R-20$ or $\geq R-13$ cavity plus $R-5$ insulated sheathing

Clarifications

Paper-faced batts may not be used on masonry walls.

Example

To ensure continuous insulation, offset double stud walls, align double stud walls with continuous insulation between adjacent stud faces, or build single-stud walls with 2x2 or 2x3 cross-framing.

Typical products for providing continuous insulation of R-13 or greater include insulated concrete forms and structurally insulated panels (SIPs). SIP walls using occasional (e.g., $\geq 4'$ on center) studs for locking mechanisms between SIP panels qualify.

Additional Resources

- [Insulation Grading - Building America Solution Center](#) | [Insulation Grading - Building America Solution Center](#) (Permalink)

Confirmation

- The EarthCraft Technical Advisor will visually confirm compliance with criteria at pre-drywall inspection.

BE 3.16 Continuous exterior insulation

Criteria

A. $\geq R-3$ (100%)

Install R-3 or greater continuous insulation on all exterior walls. Install sheathing to have no gaps greater than 1/4" and provide complete coverage. Where structural sheathing is required by code, install a structurally rated insulated sheathing or over-sheath using insulated sheathing.

B. $\geq R-5$ (100%)

Install R-5 or greater continuous insulation on all exterior walls. Install sheathing to have no gaps greater than 1/4" and provide complete coverage. Where structural sheathing is required by code, install a structurally rated insulated sheathing or over-sheath using insulated sheathing.

Clarifications

Insulated siding may not be substituted for insulated wall sheathing without preapproval by EarthCraft.

These points are attainable only for wood-framed construction at the shown R-Values. Steel framed buildings require a thermal break of R-7.5 per ASHRAE 90.1 standards. Steel framed buildings must install $\geq R-10$ Exterior Insulation to achieve A, ≥ 12.5 for B. If purlins are used to support insulation, they must be thermally broken.

Confirmation

- The EarthCraft Technical Advisor will visually confirm compliance with criteria at pre-drywall inspection.

BE 3.17 Ceilings

Criteria

1. Flat Vented: Climate Zone 4 $\geq R-60$

Insulate flat ceilings with unconditioned attic space above using R-60 or greater in Climate Zone 4. A maximum of 5% of ceiling area up to 500 sq ft may be R-38 or greater to accommodate elevated attic flooring for storage and mechanical equipment.

2. Continuous Roof Deck: Climate Zone 4 $\geq R-35$

For roofs with continuous insulation located entirely above deck, insulate to $\geq R-35$

3. Sloped: Climate Zone 4 $\geq R-49$

Insulate sloped ceilings using R-49 or greater Climate Zone 4.

Clarifications

Insulated rooflines and vaulted cathedral ceilings are not considered sloped ceilings; sloped ceilings are defined as having unconditioned attic space above.

Please see the following criteria related to insulated rooflines and vaulted cathedral ceilings:
BE 3.19: "Insulate roofline $\geq R-30$ ".

Confirmation

- The EarthCraft Technical Advisor will visually confirm compliance of criteria at final inspection.

BE 3.18 Attic kneewall insulated $\geq R-22$

Criteria

2x6 with $\geq R-19$ cavity insulation and $\geq R-3$ insulated sheathing

Construct attic kneewalls using 2x6 framing (or 2x4 framing furred out 2") and install R-19 cavity insulation. Install R-3 rigid insulated sheathing on attic side of framing. Seal top and bottom of attic side sheathing to plates and seal all seams and joints.

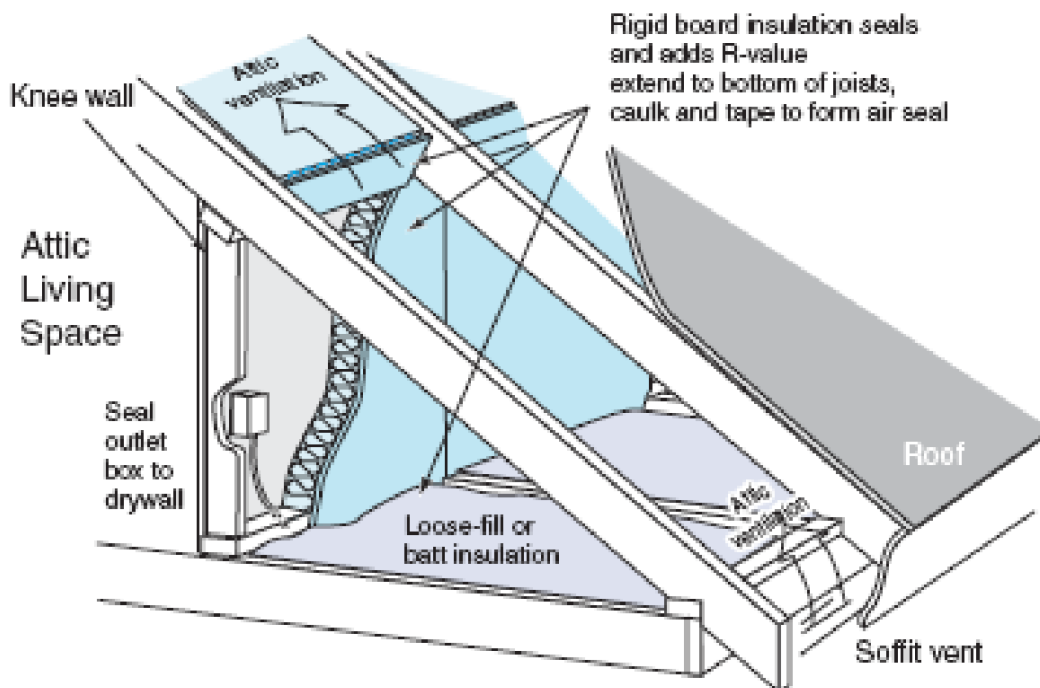

Figure 66: Attic kneewall insulation

Confirmation

- The EarthCraft Technical Advisor will visually confirm compliance of criteria at pre-drywall and final inspections.

BE 3.19 Insulate roofline to $\geq R-30$

Criteria

Insulate roofline with spray foam

Insulate roofline of attic using foam insulation $\geq R-30$ to create an unvented attic. Provide conditioning to the space directly with HVAC equipment or indirectly through a connection to conditioned space.

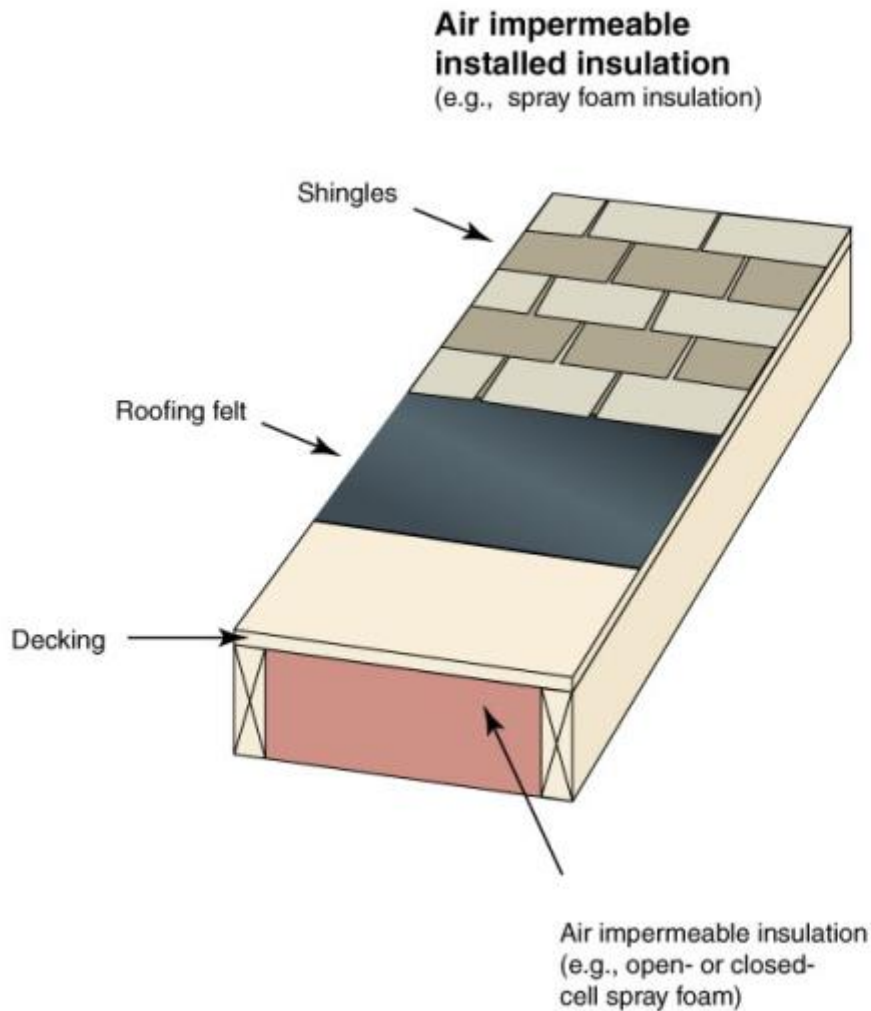

Figure 67: Insulated Roofline

Clarifications

Ridge, soffit, gable or other attic ventilation is prohibited.

Manufacturer recommended installation procedures and ignition barrier code requirements must be followed.

Confirmation

- The EarthCraft Technical Advisor will visually confirm compliance of criteria at pre-drywall and final inspections.

Windows (BE 4)

BE 4.0 Door U-factor and SHGC

Criteria

1. *U-factor: Climate Zone 4 ≤ 0.35*

All doors in Climate Zone 4 must have a U-factor less than or equal to 0.35.

2. *SHGC ≤ 0.30*

All doors in Climate Zones 4 must have a Solar Heat Gain Coefficient (SHGC) less than or equal to 0.30.

 National Fenestration Rating Council® CERTIFIED	World's Best Window Co. Millennium 2000+ Vinyl-Clad Wood Frame Double Glazing • Argon Fill • Low E Product Type: Vertical Slider
ENERGY PERFORMANCE RATINGS	
U-Factor (U.S./I-P) 0.35	Solar Heat Gain Coefficient 0.30
ADDITIONAL PERFORMANCE RATINGS	
Visible Transmittance 0.51	Air Leakage (U.S./I-P) 0.2
Condensation Resistance 51	—
<small>Manufacturer stipulates that these ratings conform to applicable NFRC procedures for determining whole product performance. NFRC ratings are determined for a fixed set of environmental conditions and a specific product size. NFRC does not recommend any product and does not warrant the suitability of any product for any specific use. Consult manufacturer's literature for other product performance information. www.nfrc.org</small>	

Figure 68: NFRC window label

Clarifications

The U-factor for doors applies to the whole door assembly not just the glass portion.

Exemptions

If a building meets the requirements for BE 4.12 “Modeled passive solar design”, windows, skylights and doors may avoid SHGC requirements based on Viridian review of design and modeling.

Confirmation

- The builder must present documentation demonstrating compliance of criteria to the EarthCraft Technical Advisor at the pre-drywall inspection.
- The EarthCraft Technical Advisor will review documentation provided by the builder for compliance of criteria.

BE 4.1 Window U-factor and SHGC

Criteria

1. *U-factor Climate Zone 4 ≤ 0.35*

All windows in Climate Zone 4 must have a U-factor less than or equal to 0.35.

2. *SHGC ≤ 0.30*

All windows in Climate Zones 4 must have a Solar Heat Gain Coefficient (SHGC) less than or equal to 0.30.

Exemptions

If a building meets the requirements for BE 4.12 “Modeled passive solar design”, windows, skylights and doors may avoid SHGC requirements based on Viridian review of design and modeling.

Confirmation

- The builder must present documentation demonstrating compliance of criteria to the EarthCraft Technical Advisor at the pre-drywall inspection.
- The EarthCraft Technical Advisor will review documentation provided by the builder for compliance of criteria.

BE 4.2 Skylight U-factor and SHGC

Criteria

1. *U-factor Climate Zone 4 ≤ 0.55*

All skylights in Climate Zone 4 must have a U-factor less than or equal to 0.55.

2. *SHGC ≤ 0.30*

All skylights in Climate Zones 4 must have a Solar Heat Gain Coefficient (SHGC) less than or equal to 0.30.

Exemptions

If a building meets the requirements for BE 4.12 “Modeled passive solar design”, windows, skylights and doors may avoid SHGC requirements based on Viridian review of design and modeling.

Confirmation

- The builder must present documentation demonstrating compliance of criteria to the EarthCraft Technical Advisor at the pre-drywall inspection.
- The EarthCraft Technical Advisor will review documentation provided by the builder for compliance of criteria.

BE 4.3 NFRC certified doors, windows, and skylights with label

Criteria

Install doors, windows and skylights labeled by the National Fenestration Rating Council (NFRC).

Exemptions

Up to 15 sq ft of glazing are exempt from this requirement.

Additional Resources

- [NFRC Certified Product Directory](#)

Confirmation

- The builder must present documentation demonstrating compliance of criteria to the EarthCraft Technical Advisor at the pre-drywall inspection.
- The EarthCraft Technical Advisor will review documentation provided by the builder for compliance of criteria.

BE 4.4 Door U-factor

Criteria

1. *Opaque door: U-factor ≤ 0.21*

All opaque doors (doors with no glass) in climate zone 2, 3, and 4 must have a U-factor of 0.21 or less.

2. *Door with \leq half-glass: U-factor ≤ 0.27*

All glass doors composed of less than half-glass or half glass must have a U-factor of 0.27 or less.

3. *Door with $>$ half-glass: U-factor ≤ 0.32*

All glass doors composed of more than half-glass must have a U-factor of 0.32 or less.

Clarifications

The U-factor for doors applies to the whole door assembly not just the glass portion. Not applicable if the door is leading to a conditioned space (i.e. conditioned corridor). Fire rated doors allowed to meet U Value requirement with door slab.

Confirmation

- The builder must present documentation demonstrating compliance of criteria to the EarthCraft Technical Advisor at the pre-drywall inspection.
- The EarthCraft Technical Advisor will review documentation provided by the builder for compliance of criteria.

BE 4.5 Window U-factor and SHGC

Criteria

1. *U-factor: Climate Zone 2 ≤ 0.45 , Climate Zone 3 ≤ 0.35 , Climate Zone 4 ≤ 0.32*

All windows in Climate Zone 2 must have a U-factor less than or equal to 0.45.

All windows in Climate Zone 3 must have a U-factor less than or equal to 0.35.

All windows in Climate Zone 4 must have a U-factor less than or equal to 0.32.

2. *SHGC: Climate Zone 2/3/4 ≤ 0.27*

All windows in Climate Zones 2, 3, and 4 must have a Solar Heat Gain Coefficient (SHGC) less than or equal to 0.27.

Clarifications

0.75% window to conditioned floor area (WFA) ratio, up to 15 square feet of window area, may be used for decorative glass that does not meet this requirement. Floor area must equal conditioned floor area used for the confirmed HERS energy model.

The U-factor for doors applies to the whole door assembly not just the glass portion.

Confirmation

- The builder must present documentation demonstrating compliance of criteria to the EarthCraft Technical Advisor at the pre-drywall inspection.

- The EarthCraft Technical Advisor will review documentation provided by the builder for compliance of criteria.

BE 4.6 Skylight U-factor and SHGC

Criteria

1. *U-factor: Climate Zone 2 ≤ 0.70 , Climate Zone 3 ≤ 0.57 , Climate Zone 4 ≤ 0.50*

All skylights in Climate Zone 2 must have a U-factor less than or equal to 0.70.

All skylights in Climate Zone 3 must have a U-factor less than or equal to 0.57.

All skylights in Climate Zone 4 must have a U-factor less than or equal to 0.55.

2. *SHGC ≤ 0.27*

All skylights in Climate Zones 2, 3, and 4 must have a Solar Heat Gain Coefficient (SHGC) less than or equal to 0.27.

Confirmation

- The builder must present documentation demonstrating compliance of criteria to the EarthCraft Technical Advisor at the pre-drywall inspection.
- The EarthCraft Technical Advisor will review documentation provided by the builder for compliance of criteria.

BE 4.7 Window U-factor and SHGC

Criteria

1. *U-factor: Climate Zone 2 ≤ 0.35 , Climate Zone 3 ≤ 0.30 , Climate Zone 4 ≤ 0.25*

All windows in Climate Zone 2 must have a U-factor less than or equal to 0.35.

All windows in Climate Zone 3 must have a U-factor less than or equal to 0.30.

All windows in Climate Zone 4 must have a U-factor less than or equal to 0.25.

2. *SHGC: Climate Zone 2/3/4 ≤ 0.24*

All windows in Climate Zones 2, 3, and 4 must have a Solar Heat Gain Coefficient (SHGC) less than or equal to 0.24.

Clarifications

0.75% window to conditioned floor area (WFA) ratio, up to 15 square feet of window area excluding western exposures, may be used for decorative glass that does not meet this requirement.

Floor area must equal conditioned floor area used for the confirmed HERS energy model.

Confirmation

- The builder must present documentation demonstrating compliance of criteria to the EarthCraft Technical Advisor at the pre-drywall inspection.
- The EarthCraft Technical Advisor will review documentation provided by the builder for compliance of criteria.

BE 4.8 Skylight U-factor and SHGC

Criteria

1. *U-factor: Climate Zone 2 ≤ 0.55 , Climate Zone 3 ≤ 0.45 , Climate Zone 4 ≤ 0.43*

All skylights in Climate Zone 2 must have a U-factor less than or equal to 0.55.

All skylights in Climate Zone 3 must have a U-factor less than or equal to 0.45.

All skylights in Climate Zone 4 must have a U-factor less than or equal to 0.43.

2. SHGC \leq 0.24

All windows in Climate Zones 2, 3, and 4 must have a Solar Heat Gain Coefficient (SHGC) less than or equal to 0.24.

Confirmation

- The builder must present documentation demonstrating compliance of criteria to the EarthCraft Technical Advisor at the pre-drywall inspection.
- The EarthCraft Technical Advisor will review documentation provided by the builder for compliance of criteria.

BE 4.9 West and East facing glazing

Criteria

1. West facing glazing \leq 2% of floor area

The total window or door glazing area within 25 degrees of due west must be less than or equal to 2% of the total conditioned floor area.

2. East facing glazing \leq 3% of floor area

The total window or door glazing area within 25 degrees of due east must be less than or equal to 3% of the total conditioned floor area.

Clarifications

Floor area must equal conditioned floor area used for the confirmed HERS energy model.

Example

A unit with total conditioned floor area of 2,000 square feet may not have more than 60 sq ft of window and door glazing area within 25 degrees of due west.

Confirmation

- The builder must present documentation demonstrating compliance of criteria to the EarthCraft Technical Advisor at the pre-drywall inspection.
- The EarthCraft Technical Advisor will review documentation provided by the builder for compliance of criteria and visually confirm at final inspection.

BE 4.10 1.5' overhangs over 80% of south-facing window area

Criteria

Maintain a 1.5' overhangs on 80% of all south-facing window area to protect against moisture and summer solar gain. Maximum overhang height above window is 2'.

Clarifications

Installed gutters may not contribute to the 1.5' distance.

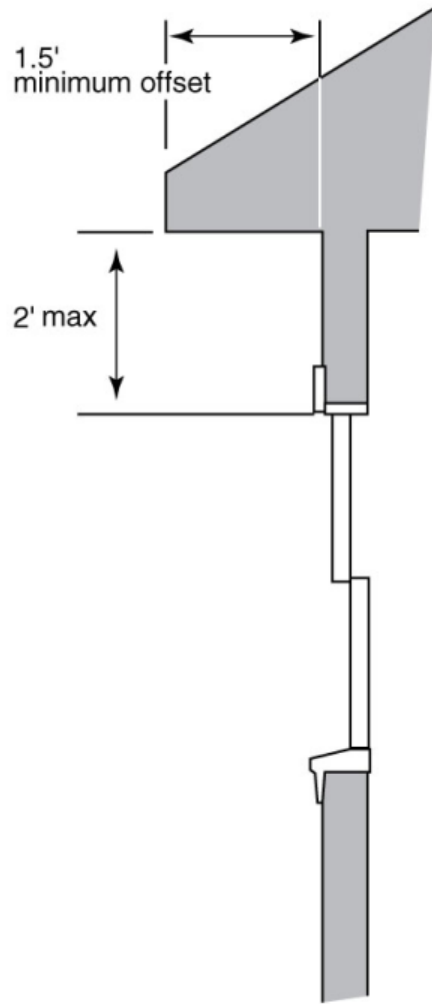

Figure 69: Window overhang

Additional Resources

- To analyze the shading performance of an overhang see: www.susdesign.com/overhang/index.php.

Confirmation

- The EarthCraft Technical Advisor will visually confirm compliance of criteria at pre-drywall inspection.

BE 4.11 Solar shade screens (all east and west facing windows)

Criteria

Install solar shade screens on all east and west facing windows with a shading coefficient of 0.7 or greater. Shade screen must be installed on exterior of window glazing.

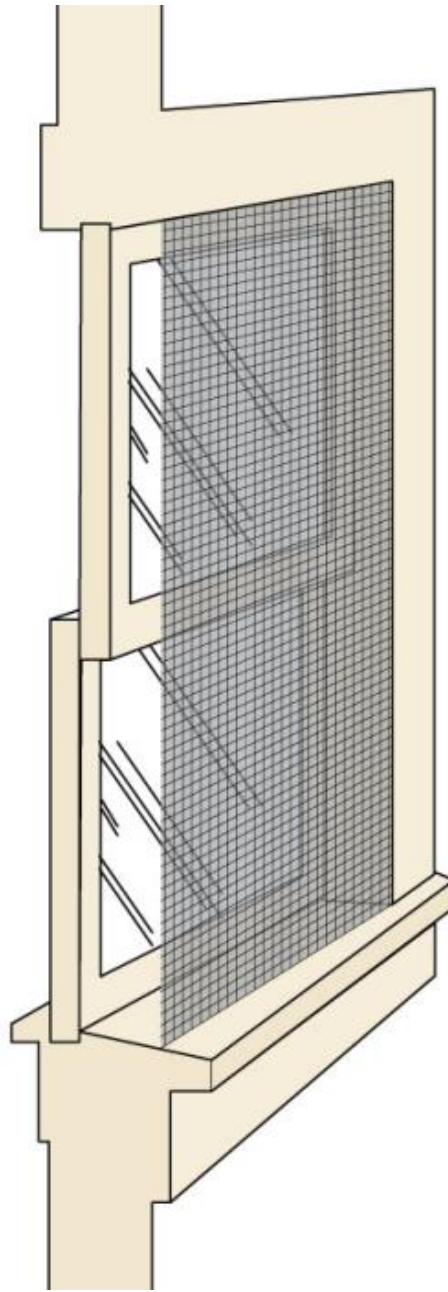

Figure 70: Solar shade screen

Confirmation

- The EarthCraft Technical Advisor will visually confirm compliance of criteria at final inspection.

BE 4.12 Modeled passive solar design (25% load reduction)

Criteria

Modeled passive solar heating contribution reduces the total heating loads by 25% or greater and does not increase cooling loads by more than 10%. Certification must be based on EarthCraft approved modeling program.

Clarifications

EarthCraft window Solar Heat Gain requirements do not need to be met if windows are facing within 15 degrees of true south and directly coupled to a thermal storage mass that has a heat capacity ≥ 20 Btu/ft³ \times °F and provided in a ratio of at least 3 sq ft per sq ft of south facing fenestration. For the required heat capacity, thermal masses typically must be at least 2" thick. Code compliance must be demonstrated using modeling software.

Additional Resources:

- [WUFI Passive Software Tool](#) | [WUFI Passive Software Tool](#) (Permalink)
- [Energy.gov - Passive Solar Home Design](#)

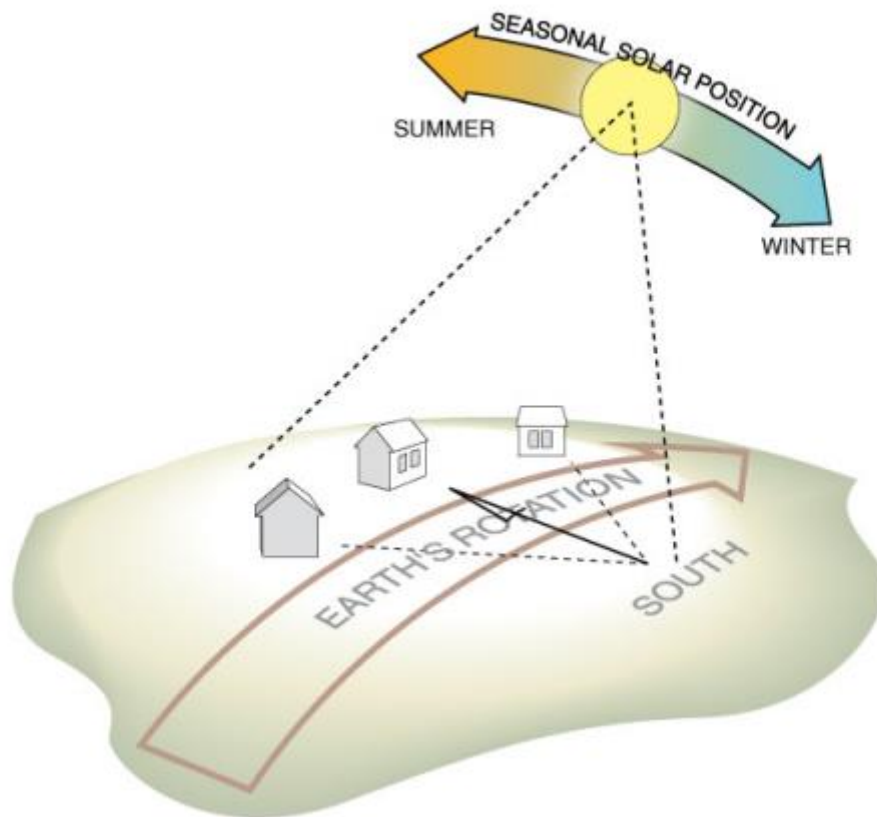

Figure 71: Seasonal solar position

Confirmation

- The project team must submit documentation demonstrating compliance with criteria to the EarthCraft Technical Advisor at the pre-drywall inspection.
- The EarthCraft Technical Advisor will review documentation provided by the project team for compliance with criteria.

BE 4.13 Window area is $\leq 15\%$ of conditioned floor area (all units)

Criteria

To improve energy efficiency and comfort by reducing the solar heat gain into individual units. Keeping the window to conditioned floor area ratio at a minimum will improve the results of the unit level energy models.

Example

Area of glazing equals 100 square feet and conditioned floor area of unit is equal to 850 square feet.

$$\frac{100\text{sf of glazing}}{850\text{sf of floor area}} = .118 \text{ ratio or } 11.8\%$$

Confirmation

- The project team must submit unit level calculations demonstrating compliance with criteria.
- The EarthCraft Technical Advisor will visually verify window to CFA ratios during site inspections.

Roof (BE 5)

BE 5.0 If Ducts located in unconditioned attic:

Criteria

1. Attic Side Radiant Barrier

If more than 10 linear feet of ductwork are located in an unconditioned attic, install a radiant barrier with a minimum initial reflectance of 0.90 and maximum initial emittance of 0.10 on all sloped roofs above vented attics.

Install radiant barrier so that foil is facing down and not in direct contact with any building materials other than roof rafters.

Any uninsulated attic surfaces must have a radiant barrier installed. This includes sloped roof decks as well as gable end walls.

2. ENERGY STAR qualified roof ($\geq 75\%$ of total roof area)

If more than 10 linear feet of ductwork are located in an unconditioned attic, install ENERGY STAR qualified roof product on 75% of total roof area (including attached garages).

Clarifications

As products and ENERGY STAR qualifications are periodically updated, the product must be on the list of ENERGY STAR qualified products at the time it was purchased.

This is not applicable at the PLATINUM level because at that level all ductwork must be located in conditioned space.

Additional Resources

- [ENERGY STAR Qualified Roof Products](#) | [ENERGY STAR Qualified Roof Products](#) (Permalink)
- <https://www.energy.gov/eere/femp/purchasing-energy-efficient-cool-roof-products>

Confirmation

Radiant Barrier

- The EarthCraft Technical Advisor will visually confirm compliance with criteria at pre-drywall inspection.
- The project team must present documentation demonstrating ENERGY STAR compliance for roof products.
- The EarthCraft Technical Advisor will review documentation provided by the project team and visually confirm compliance.

BE 5.1 Install green roof system

Criteria

Install a green roof system on a percentage of the total roof area across the development in order to manage stormwater runoff and combat the heat island effect.

- $\geq 20\%$ of roof area is covered by a green roof system.
- $\geq 40\%$ of roof area is covered by a green roof system.
- $\geq 60\%$ of roof area is covered by a green roof system.

Example

A roof partially or completely covered by vegetation on top of a growing medium and a waterproof membrane.

Confirmation

- The project team must provide design details demonstrating compliance with criteria at a specified level (20%/40%/60%).
- The EarthCraft Technical Advisor will visually confirm compliance with criteria at final inspection.

Energy Efficient Systems (ES)

Heating and Cooling (ES 1)

ES 1.0 Size and select all HVAC equipment with ACCA Manuals J and S

Criteria

Size and select all HVAC equipment in accordance with ACCA Manuals J and S. Load calculation must coordinate with accurate construction specifications and plans for the project as well as as-built conditions.

1. *Complete load calculation with accredited ACCA Manual J 8th Edition Software*

Load calculation must be based on ACCA Manual J 8th Edition Software. The following software programs are ACCA Manual J 8th Edition or later compliant:

- <https://www.acca.org/standards/approved-software>

2. *Based on worst case unit orientation*

Load calculation must be based on worst case orientation for each unit type as constructed.

3. *Use 2017 ASHRAE Handbook of Fundamentals Climate Design Information for outdoor design temperatures*

Design heating and cooling systems using the annual outdoor design conditions as defined in the 2017 ASHRAE Handbook of Fundamentals, Chapter 14.

- The 99% design conditions must be used to size heating equipment
- The 1% design conditions must be used to size cooling equipment

4. *Indoor temperatures 70°F for heating and 75°F for cooling*

Design heating and cooling systems using indoor design temperatures of 70°F for heating and 75°F for cooling.

5. *Base infiltration on project team selected infiltration goal.*

Select project team infiltration goal or software equivalent for unit infiltration.

6. *Use actual area, U-factor and SHGC for windows and doors, actual area and R-values of floors, walls and ceilings*

Load calculation must be based on actual window, insulation and door specifications as installed. Window, door, wall, floor, and ceiling areas must be ±10% of actual areas as constructed.

7. *Base mechanical ventilation on ASHRAE 62.2-2010 standard*

Load calculation must be based on ventilation system designed and installed to meet ASHRAE 62.2-2010. This includes the ventilation system type, location, design rate, and frequency and duration of each ventilation cycle.

8. *Cooling equipment and/or single-stage heat pump between 95-125%*

Cooling equipment selection must be between 95-115% of load calculation or the next available size unit. Installed heat pumps in Climate Zone 4 must be within 125% of load calculation or the next available size unit.

9. Provide OEM data for each unique system type

10. Internal loads that reflect design and occupancy ≤2400 Btu/h

Internal loads from equipment should reflect the design of the apartment and be no more than 2,400 Btu/h. Internal loads from occupants should show the total number of people in the dwelling unit as the number of bedrooms + 1.

Clarifications

The abridged edition of ACCA Manual J is not an acceptable methodology within the EarthCraft program.

Trane Trace is not acceptable for low-rise buildings with individual HVAC systems.

Multispeed or multistage equipment may have OEM nominal size increments of one ton.

Therefore, the use of multispeed or multistage equipment can provide extra flexibility to meet the equipment sizing requirements. The equipment oversizing limit should be based on the largest capacity of the unit.

Floor area must equal conditioned floor area used for the confirmed HERS energy model.

Base infiltration may use more stringent criteria such as “tight” for whole house infiltration.

Example #1

Equipment sizing selection:

If the load calculation specifies a total sensible load of 36,000 Btuh, the 115% oversizing limit allows for using up to 41,400 Btuh:

$$36,000 \times 1.15 = 41,400 \text{ Btuh}$$

If Manufacturer X (the trusted brand of Builder Y) makes a nominal 3 ton unit and a nominal 4 ton unit, but no sizes in between, then Builder Y may install the 4 ton unit made by Manufacturer X as long the nominal 3 ton unit has insufficient capacity (i.e. total capacity of 33,000 Btuh). Alternately, if Builder Y wanted to use equipment from Manufacturer Z and Manufacturer Z offers nominal 3 ton (33,000 Btuh), 3.5 ton (39,400 Btuh) and 4 ton units (45,800 Btuh), then Builder Y must install the nominal 3.5 ton unit by Manufacturer Z because the unit is between the Manual J specification and the 125% oversizing limit required by EarthCraft.

Additional Resources

- [2009/2013/2017 ASHRAE Climatic Design Conditions](#)
- Air Conditioning Contractors of America, see www.acca.org

Confirmation

- The Project must submit documentation demonstrating compliance of criteria to the EarthCraft Project Manager prior to the Design Review meeting.
- The EarthCraft Project Manager will review documentation provided for compliance of criteria
- The Technical Advisor will visually confirm compliance of criteria at pre-drywall and final inspections.

ES 1.1 If programmable thermostat installed for heat pump, include adaptive recovery technology

Criteria

If a heat pump is installed and a programmable thermostat is used, the thermostat must be equipped with an adaptive recovery technology. Adaptive recovery prevents the system from relying on strip heat to quickly raise temperatures also resulting in increased energy use.

Confirmation

- The project team must present documentation demonstrating compliance with criteria to the EarthCraft Technical Advisor at the pre-drywall inspection. If necessary, the mechanical contractor must confirm in writing that the adaptive recovery system has been activated during installation.
- The EarthCraft Technical Advisor will review documentation provided by the project team for compliance with criteria and will visually confirm compliance with criteria at final inspection.

ES 1.2 AHRI performance match all indoor/outdoor coils

Criteria

Indoor and outdoor coils must be matched in accordance with Air-Conditioning, Heating, and Refrigeration Institute (AHRI) standards.

Additional Resources

- www.ahridirectory.org

Confirmation

- The project team must submit documentation demonstrating compliance with criteria at Design Review.
- The EarthCraft Technical Advisor will review documentation provided by the project team for compliance with criteria and will visually confirm compliance with criteria at final inspection.

ES 1.3 Non-CFC and non-HCFC refrigerant

Criteria

Install cooling equipment that contains non-CFC or non-HCFC refrigerant (e.g., R410a).

Exemptions

Projects not using any refrigerants automatically meet intent provided they demonstrate alternative cooling strategies appropriate for a mixed-humid climate.

Confirmation

- The project team must present documentation demonstrating compliance with criteria to the EarthCraft Technical Advisor at the pre-drywall inspection.
- The EarthCraft Technical Advisor will review documentation provided by the project team for compliance with criteria.

ES 1.4 No electric resistance heat as primary heat source or reheat

Criteria

Electric resistance heaters, such as an electric furnace, electric radiant or a baseboard heater, may not be used as the primary heat source for any portion of the conditioned space or used in a reheat design.

Confirmation

- The EarthCraft Technical Advisor will visually confirm compliance with criteria at pre-drywall and final inspections.

ES 1.5 Heat pump efficiency \geq 8.2 HSPF or equivalent COP

Criteria

Heat pumps must have an efficiency of at least 8.2 HSPF or greater per AHRI Certificate.

Clarification

Project team must provide documentation showing COP equivalency.

Confirmation

- The EarthCraft Technical Advisor will visually confirm compliance with criteria at final inspection.

ES 1.6 Furnace efficiency \geq 90 AFUE

Criteria

Furnaces must be rated at least 90 AFUE per AHRI Certificate.

Confirmation

- The EarthCraft Technical Advisor will visually confirm compliance with criteria at final inspection.

ES 1.7 Cooling equipment \geq 14 SEER or 11 EER

Criteria

Cooling equipment must equal or surpass 14 SEER or 11 EER ratings.

Confirmation

- The EarthCraft Technical Advisor will visually confirm compliance with criteria at final inspection.

ES 1.8 Heating equipment efficiency

Criteria

A. ENERGY STAR qualified furnace(s) \geq 95% AFUE and within 40% of load calculation

All heating equipment must be ENERGY STAR qualified and 90%+ Annual Fuel Utilization Efficiency (AFUE) for gas combustion furnaces. All furnaces must be sized within 40% of the heating load as determined by the load calculation.

B. ENERGY STAR qualified heat pump(s) \geq 8.5 HSPF and within 25% of load calculation

All heating equipment must be ENERGY STAR qualified meeting an 8.5+ Heating Seasonal Performance Factor (HSPF) for heat pumps.

Heat pumps in Climate Zone 4 must be within 25% of the load calculation or the next available size.

Clarifications

As products and ENERGY STAR qualifications are periodically updated, the product must be on the list of ENERGY STAR qualified products at the time it was purchased.

For heat pumps, the specific combination of indoor and outdoor units must be ENERGY STAR qualified.

Additional Resources

- A list of qualified products can be found at: <https://www.energystar.gov/productfinder/>
- Qualified matched equipment can be confirmed at: <http://www.ceedirectory.org/>

Confirmation

- The project team must present documentation demonstrating compliance with criteria to the EarthCraft Technical Advisor at the pre-drywall inspection.
- The EarthCraft Technical Advisor will review documentation provided by the project team for compliance with criteria and will visually confirm compliance with criteria at final inspection.

ES 1.9 Verification of proper refrigerant charge with subcooling deviation $\pm 3^{\circ}\text{F}$ or superheat deviation $\pm 5^{\circ}\text{F}$

Criteria

Perform refrigerant charge test to ensure appropriate charge for HVAC equipment with subcooling deviation $\pm 3^{\circ}\text{F}$ or superheat deviation $\pm 5^{\circ}\text{F}$. Document test results in Section 2 of the [ENERGY STAR MFNC HVAC Functional Testing Checklist](#) or create customized form containing same information.

Clarifications

This requirement may be met by any of the following methods according to [ANSI/ACCA 5 QI - 2015](#):

- Superheat method test measurement within 5% of the manufacturer-recommended charge
- Subcooling method test measurement within 3% of the manufacturer-recommended charge
- Other equivalent method/tolerance approved by the equipment manufacturer.

Geothermal heat pumps, mini-split heat pumps and hermetically sealed factory-charged stems may not be appropriate for standard subcooling or superheat refrigerant charge testing. To accommodate these system types, an OEM (original equipment manufacturer) test procedure may be used and documented.

Additional Resources

- [Guidelines on Airflow and Refrigerant Charge Verification and Diagnostics](#)
- [EPA - Guide to Good Leak Testing pg. 7](#)
- [ACCA Standard 9 - HVAC Quality Installation Verification Protocols](#)

Confirmation

- The project team must submit documentation demonstrating compliance with criteria to the EarthCraft Technical Advisor at the final inspection.
- The EarthCraft Technical Advisor will review documentation provided by the project team for compliance with criteria.

ES 1.10 ENERGY STAR qualified cooling equipment ≥ 15 SEER

Criteria

Install high efficiency ENERGY STAR qualified cooling equipment (SEER 15 or better). All cooling equipment must have a minimum Seasonal Energy Efficiency Ratio (SEER) of 15 or a minimum of 12.5 Energy Efficiency Ratio (EER). An AHRI certificate should be provided to the Technical Advisor showing the SEER or EER rating of each unit.

Clarifications

As products and ENERGY STAR qualifications are periodically updated, the product must be on the list of ENERGY STAR qualified products at the time it was purchased.

For heat pumps, the specific combination of indoor and outdoor units must be ENERGY STAR qualified.

Additional Resources

- A list of qualified products can be found at: <https://www.energystar.gov/productfinder/>
- Qualified matched equipment can be confirmed at: <http://www.ceedirectory.org/>

Confirmation

- The EarthCraft Technical Advisor will visually confirm compliance with criteria at final inspection.

ES 1.11 Use ACCA Approved Residential Load Calculation Software to produce loads

Criteria

Use Air Conditioning Contractors of America (ACCA) approved software designed for residential load calculations to produce Room by Room Load Calculations including detailed inputs. ACCA Approved Software can be found at <https://www.acca.org/standards/approved-software>

Confirmation

- The Project must submit documentation demonstrating compliance of criteria to the EarthCraft Project Manager prior to the Design Review meeting.
- The EarthCraft Project Manager will review documentation provided for compliance of criteria

1.12 Load Calculation comply with ES 1.0 at first submission (no revision required)

Criteria

Submit Load Calculations following ACCA best practices as outlined in Required Item ES 1.0 and reflecting actual locations of dwelling units and project specifications.

Confirmation

- The Project must submit Load Calculations prior to Design Review
- The EarthCraft Project Manager will review Load Calculations for compliance with criteria.
- The EarthCraft Technical Advisor will visually verify installed equipment matches approved load calculations.

ES 1.13 Variable speed blower

Criteria

Install variable speed blower fan to allow for improved humidity removal and quieter operation. System must be installed such that static pressure across the blower with filter installed is within manufacturer specifications.

Clarifications

Multi-speed air handlers do not meet this credit intent.

Additional Resources

- [ECM Air Handler Fans - PNNL](#) | [ECM Air Handler Fans - PNNL](#) (Permalink)

Confirmation

- The builder must submit documentation demonstrating compliance of criteria to the EarthCraft Technical Advisor at the final inspection.

- The EarthCraft Technical Advisor will review documentation provided by the builder for compliance of criteria.

ES 1.14 Ground-source heat pump(s) \geq 17 EER

Criteria

Install a ground-source heat pump for whole-house heating and cooling. All ground-source heat pumps must have a minimum cooling Energy Efficiency Ratio (EER) of 17 and a minimum heating Coefficient of Performance (COP) of 3.5 as determined by the Air Conditioning, Heating and Refrigeration Institute (AHRI).

Additional Resources

- Air Conditioning, Heating and Refrigeration Institute (AHRI) at <http://www.ahrinet.org>.

Confirmation

- The builder must submit documentation demonstrating compliance of criteria to the EarthCraft Technical Advisor at the pre-drywall inspection.
- The EarthCraft Technical Advisor will review documentation provided by the builder for compliance of criteria and will visually confirm compliance of criteria at pre-drywall and final inspections.

ES 1.15 ENERGY STAR qualified cooling equipment \geq 16 SEER

Criteria

Install high efficiency ENERGY STAR qualified cooling equipment (SEER 16.0+). All cooling equipment must have a minimum Seasonal Energy Efficiency Ratio (SEER) of 16.0 or a minimum of 13 Energy Efficiency Ratio (EER). Provide documentation showing the SEER or EER rating of each unit.

Clarifications

As products and ENERGY STAR qualifications are periodically updated, the product must be on the list of ENERGY STAR qualified products at the time it was purchased.

For heat pumps, the specific combination of indoor and outdoor units must be ENERGY STAR qualified.

Additional Resources

- A list of qualified products can be found at: <https://www.energystar.gov/productfinder/>
- Qualified matched equipment can be confirmed at: <http://www.ceedirectory.org/>

Confirmation

- The EarthCraft Technical Advisor will visually confirm compliance of criteria at final inspection.

ES 1.16 Heat pump efficiency \geq 9.0 HSPF

Criteria

Installed heat pumps must have an efficiency rating of at least 9.0 HSPF.

Confirmation

- The EarthCraft Technical Advisor will visually confirm compliance with criteria at final inspection.

ES 1.17 Dual-stage compressor

Criteria

All cooling equipment must have a dual-stage (or two-stage) compressor for improved humidity removal and increased efficiency. The higher stage compressor must comply with the maximum 25% oversizing criteria as required for all cooling equipment.

Clarifications

When a dual-stage compressor is used for a heat pump to lower the balance point, size the air conditioner at design conditions for the lower fan speed only. The second stage should not come on at design temperatures. Use the second stage to size the heat pump at design heating conditions.

Confirmation

- The EarthCraft Technical Advisor will visually confirm compliance with criteria at final inspection.

ES 1.18 Condenser units are spaced 2 feet apart

Criteria

Condenser units must be spaced at least 2 feet apart to reduce restriction of airflow across the condensing coil.

ES 1.19 Variable Refrigerant/Mini-Split system utilized for primary heating and cooling

Criteria

Primary heating and cooling provided to the space using Variable Refrigerant/Mini-Split system.

Confirmation

- The EarthCraft Technical Advisor will visually confirm compliance of criteria at pre-drywall and final inspections.

ES 2.0 Seal air handlers and duct systems with mastic

Criteria

Seal all seams, joints, and connections in forced-air delivery systems using mastic paste or Butyl rubber backed foil tape (mastic tape), including but not limited to:

- Supply and return ducts
- Supply and return plenums
- Duct-to-plenum connection
- Y-splits, butt joints, and boot connections
- Outdoor air intakes
- Air handler condensate and refrigerant line, wire penetrations, and unused holes in the air handler cabinet

Wrap mastic tape at least two times around duct seam touching at least 1 1/2" of duct inner liner and metal collar or sleeve. Assemble duct board using code-approved foil tape and coat seams with layer of mastic paste covering seams by 1.5" on both sides and as thick as a nickel.

Clarifications

Duct tape is not a suitable sealant for ducts. Foil tape may only be used for sealing leaks at the air handler's removable access panels and at filter access panels. Duct boots may be sealed to floor, wall, or ceiling using caulk, foam, mastic tape (UL 181 BM), or mastic paste.

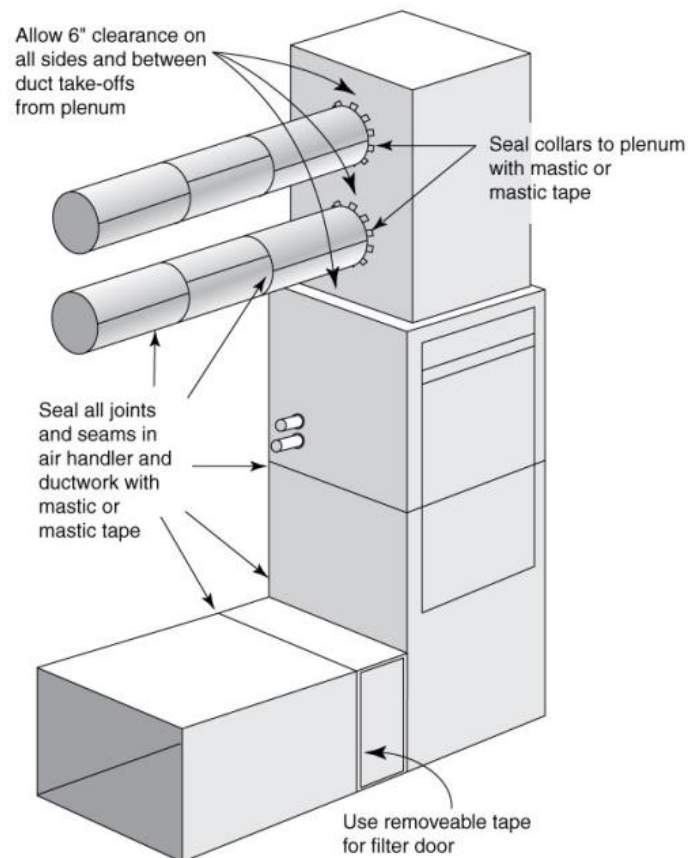

Figure 72: Common mastic locations

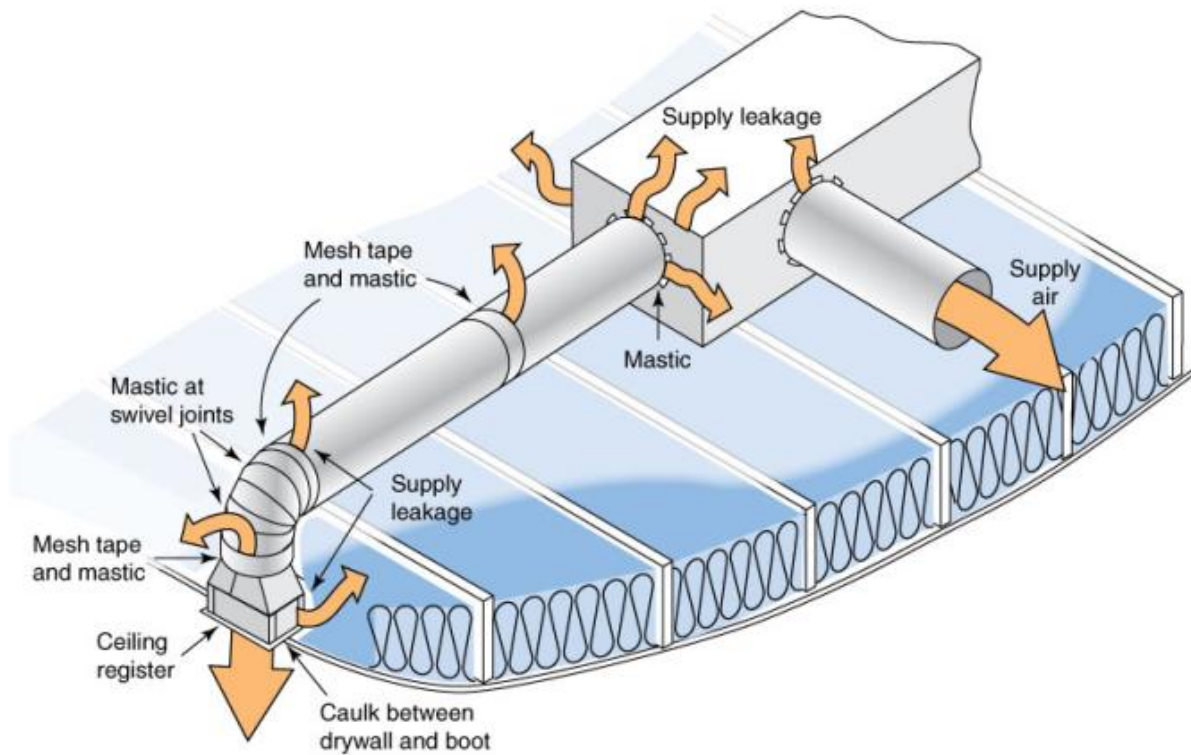

Figure 73: Common mastic locations (1)

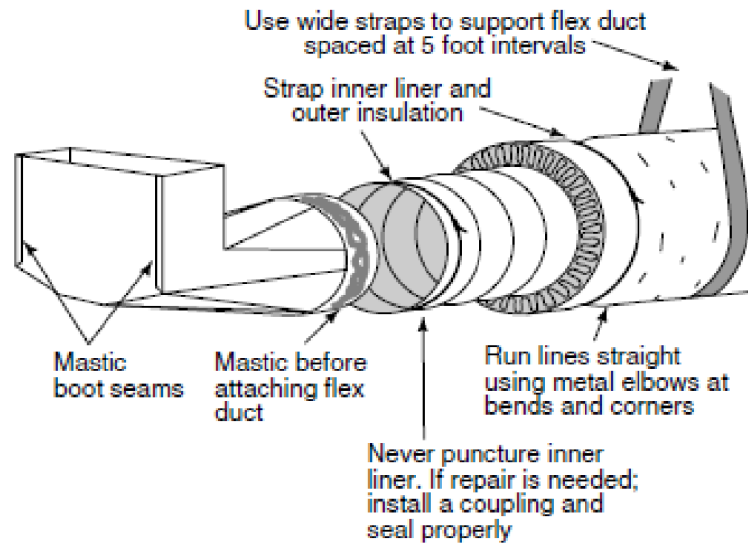

Figure 74: Common mastic locations (2)

Confirmation

- The EarthCraft Technical Advisor will visually confirm compliance of criteria at pre-drywall and final inspections.

ES 2.1 Code approved solid connector for all flex to flex connections

Criteria

Connect all flex-to-flex duct connections together using code approved rigid connectors or sleeves. Connect flex duct liner to sleeve using a duct tie and mastic paste or Butyl rubber backed foil tape (mastic tape).

Confirmation

- The EarthCraft Technical Advisor will visually confirm compliance of criteria at pre-drywall and final inspections.

ES 2.2 Fully duct all supply and return ducts

Criteria

Install all supply and return ducts using code approved air duct materials.

Clarifications

Do not use building cavities as a supply duct (e.g., panned joists and stud cavities are not allowed as supply or return ducts).

Supplies located in toe kicks must be fully ducted and sealed to the exterior face of the toe-kick.

Confirmation

- The EarthCraft Technical Advisor will visually confirm compliance of criteria at pre-drywall inspection.

ES 2.3 Duct insulation

Criteria

1. R-6: Conditioned spaces

All ducts located in conditioned space and interstitial spaces (between floors) must be insulated to R-6. Exhaust ducts in full baths and fresh air ducts must also comply.

2. R-8: Unconditioned attics and exterior

Insulate all supply, return, ventilation and exhaust ducts and all duct connections in unconditioned attics and exterior locations using R-8 insulation or greater.

Clarifications

Ducts left completely exposed inside conditioned space (e.g., modern loft-style duct systems) are not required to be insulated but must be at minimum 90% visible at final inspection.

Confirmation

- The EarthCraft Technical Advisor will visually confirm compliance of criteria at pre-drywall and final inspections.

ES 2.4 No ducts in exterior walls or vaulted ceilings

Criteria

Design and install duct layout such that no ducts are located in exterior walls or insulated vaulted ceilings. This includes insulated walls between conditioned and unconditioned space such as the common wall between the stairwell and the unit.

Clarifications

Ducts in exterior walls may be installed if a minimum of R-6 continuous insulation (in addition to the required duct and wall insulation) is provided on the exterior side of the cavity with an interior and exterior air barrier, and the wall cavity is large enough to accommodate the full duct diameter with no crimps.

Confirmation

- The EarthCraft Technical Advisor will visually confirm compliance of criteria at pre-drywall inspection.

ES 2.5 Locate air handler within conditioned space

Criteria

Locate all air handlers within conditioned space.

Clarifications

Any atmospherically vented furnace (e.g., 80 AFUE furnaces) are required to be isolated from conditioned space (e.g., located in combustion closets) and thus are not considered to be within conditioned space.

Example

A sealed combustion, 90% furnace or heat pump located within conditioned space would satisfy this requirement.

Confirmation

- The EarthCraft Technical Advisor will visually confirm compliance of criteria at pre-drywall and final inspections.

ES 2.6 Indoor coil protected

Criteria

Protect and cover indoor coil until finished floor is installed to reduce particulate matter and pollutants from entering the HVAC system.

Confirmation

- The EarthCraft Technical Advisor will visually confirm compliance with criteria at pre-drywall and final inspections.

ES 2.7 Minimize pressure imbalance within units ≤ 6 pa between bedroom and return

Criteria

Reduce pressure imbalance between bedrooms and area of central return (living room) through various methods including appropriate duct sizing, door undercuts, dedicated return ducts, jumper ducts, transfer grilles or other.

Measured Pressure imbalance must achieve ≤ 6 pa between bedrooms and central return.

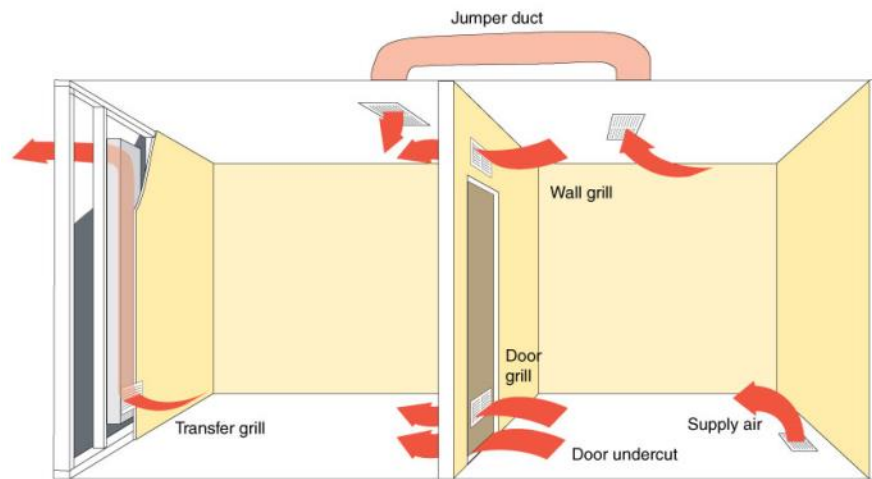

Figure 75: Return air pathways

Additional Resources

- [Building Science: Transfer Grille Sizing](#)
- [Transfer Grilles | Building America Solution Center](#)
- http://www.ba-pirc.org/casestud/return_air/index.htm

Confirmation

- The EarthCraft Technical Advisor will visually confirm compliance with criteria at pre-drywall and final inspections.

ES 2.8 No duct take-offs within 6" supply plenum or supply trunk cap

Criteria

To improve airflow efficiency to all rooms no duct take-offs may be installed within 6" of supply plenum cap or supply trunk line and no ducts may be installed at the end cap of the supply plenum or supply trunk line.

Confirmation

- The EarthCraft Technical Advisor will visually confirm compliance with criteria at pre-drywall and final inspections.

ES 2.9 Design and construct accessible mechanical closets

Criteria

Design and construct mechanical closets that are easily accessible for routine maintenance, repairs, and filter replacement.

Confirmation

- The EarthCraft Technical Advisor will visually confirm compliance of criteria at pre-drywall and final inspections.

ES 2.10 Install ducts per ACCA Manual D duct design

Criteria

Design and install ductwork in accordance with ACCA Manual D guidelines latest edition or equivalent ASHRAE Handbook of Fundamentals method. Integrate duct layout with construction documentation to ensure proper installation and provide clash detection. At a minimum, duct layout must document duct diameter and length, and register location.

Additional Resources

- [ACCA Manual D Spreadsheet](#)
- [ACCA Manual D Checklist](#)

Confirmation

- The builder must submit documentation demonstrating compliance of criteria to the EarthCraft Technical Advisor at the pre-drywall inspection.
- The EarthCraft Technical Advisor will review documentation provided by the builder for compliance of criteria and will visually confirm compliance of criteria at pre-drywall inspection.

ES 2.11 Minimize pressure imbalance within units ≤ 3 pa

Criteria

1. *Reduce pressure imbalance between bedrooms and area of central return (living room) through various methods including dedicated return ducts, jumper ducts, or transfer grills.*
2. *Measured Pressure imbalance must achieve ≤ 3 pa between bedrooms and central return.*

Clarification

See Figure 75 (above) or the additional resources below for additional information.

Additional Resources

- [Building Science: Transfer Grille Sizing](#)
- [Transfer Grilles | Building America Solution Center](#)
- http://www.ba-pirc.org/casestud/return_air/index.htm

Confirmation

- The EarthCraft Technical Advisor will visually confirm compliance with criteria at pre-drywall inspection and will diagnostically test for compliance with criteria at the final inspection.

ES 2.12 Install rigid duct work or pull all flex duct tight with no pinches and support at intervals $\leq 5'$

Criteria

Construct all duct work using rigid duct materials (sheet metal or duct board) or ensure all flex duct is pulled tight and that inner liner is not constricted to allow for optimal airflow. Bends in flex duct must have a radius of at least the diameter of the duct or more. Use balancing dampers instead of loops to limit flow to diffusers, and use baffles for acoustical control. Support flexible ducts at intervals recommended by the Manufacturers, but at least every 5 feet using bands that are at least 1 1/2" wide, and located above ceiling insulation to prevent condensation.

Clarifications

Do not install ducts in contact with roof decking.

Do not install flex duct located in unconditioned spaces in cavities smaller than the outer duct diameter or flex duct located in conditioned spaces in cavities smaller than the inner duct diameter.

Examples

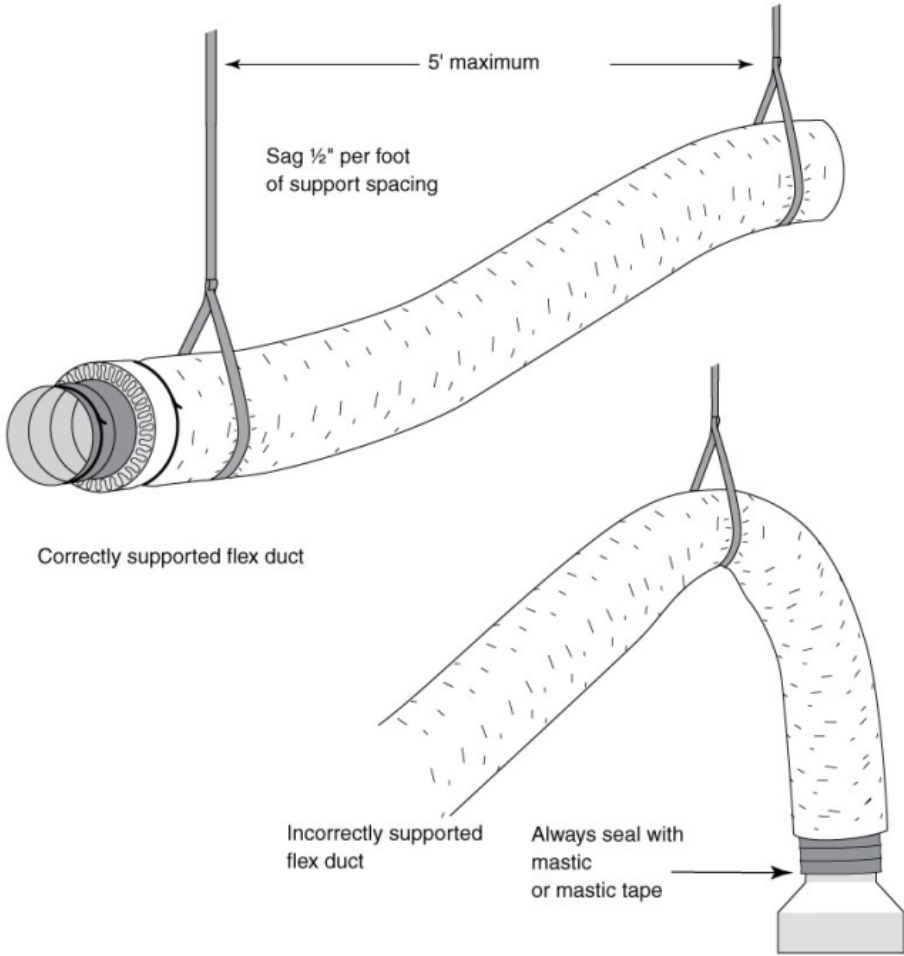
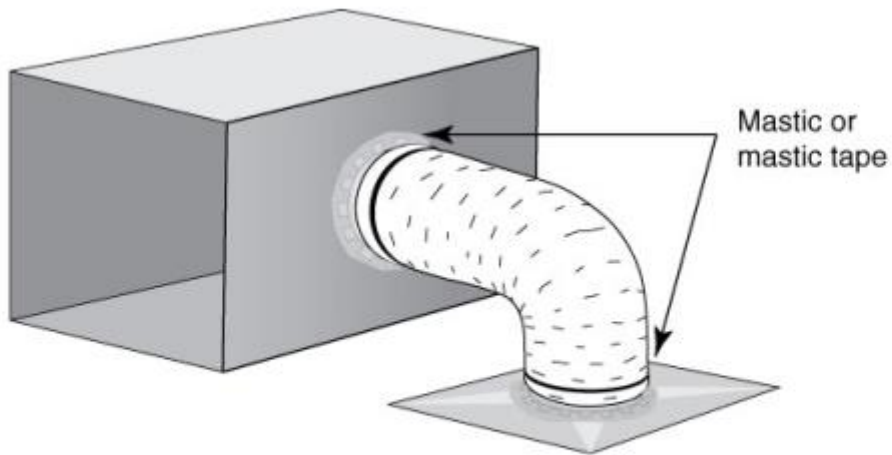
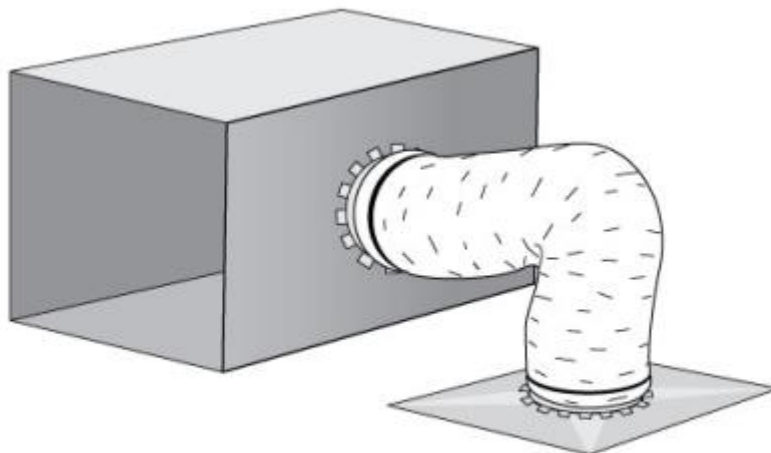

Figure 76: Correct (top) and incorrect (bottom) ductwork installation



Correct: flex duct installed with enough material, to create smooth turns with proper angles



Incorrect: flex duct installed with extra material, creating bunched turns with pinched angles

Figure 77: Correct (top) and incorrect (bottom) ductwork installation

Additional Resources

- [Advanced Design Guideline - Section 2.1.2](#)

Confirmation

- The EarthCraft Technical Advisor will visually confirm compliance of criteria at pre-drywall and final inspections.

ES 2.13 Measure and balance airflow for each duct run

Criteria

Measure and balance airflow for each room using a flow hood, anemometer or EarthCraft approved equivalent with all interior doors closed. Adjust airflow to within the greater of $\pm 20\%$ or 25 cfm of the load calculation room-by-room specifications.

Clarifications

Ducts shall not include coiled or looped ductwork. Balancing dampers or proper duct sizing shall be used instead of loops to limit flow to diffusers.

When balancing dampers are used, they shall be located at the trunk to limit noise unless the trunk will not be accessible when the balancing process is conducted. In such cases, opposable blade dampers or dampers located in the duct boot are permitted.

The diffuser lever at the grille may not be used for balancing unless it is tamper-resistant or the correct position for the lever is clearly and permanently marked.

The airflow must be balanced for each run in every residential unit and a report provided to achieve this credit.

Confirmation

- The builder must submit documentation demonstrating compliance of criteria to the EarthCraft Technical Advisor at the final inspection.
- The EarthCraft Technical Advisor will sample for compliance against final TAB results.

ES 2.14 Verify supply and return duct static pressure

Criteria

Verify supply and return duct static pressure is within manufacturer and design specifications to have the capacity to meet the calculated loads.

Clarifications

Pressure must be measured in the ducts and not in the air handler itself.

HVAC contractor must provide test-hole locations. They must be well marked and easily accessible for verification. Supply and return duct static pressure measurements in inches of water column (IWC) must be submitted to builder by HVAC contractor.

Verification of static pressure using the same test holes must confirm results are <110% of contractor values.

Confirmation

- The builder must present documentation demonstrating compliance of criteria to the EarthCraft Technical Advisor at the final inspection.
- The EarthCraft Technical Advisor will review documentation provided by the builder for compliance of criteria and will diagnostically test compliance of criteria at the final inspection.

ES 2.15 HVAC system and ductwork is dry and clean

Criteria

Inspect ductwork before installing registers, grilles, and diffusers to verify it is dry and substantially free of dust or debris, and that there are no disconnects or visible air gaps.

Inspect air-handling equipment and verify that heat exchangers/coils are free of dust caused by construction activities and the filter is new. After installation of registers, grilles, and diffusers, verify detectable airflow from each supply outlet.

Clarifications

If duct openings were uncovered during construction, thoroughly vacuum out each opening prior to installing registers, grilles and diffusers.

Confirmation

- The EarthCraft Technical Advisor will visually confirm compliance of criteria with the builder at the final inspection.

ES 2.16 Locate entire duct system within conditioned space

Criteria

Locate entire supply and return ducts within conditioned space.

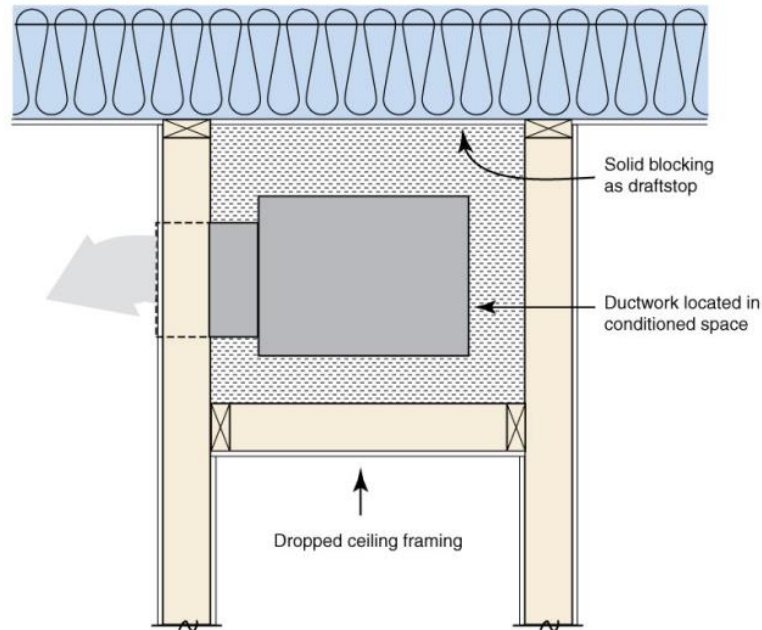

Figure 78: Ducts in conditioned space

Confirmation

- The EarthCraft Technical Advisor will visually confirm compliance of criteria at pre-drywall and final inspections.

ES 2.17 Duct design and installation

Criteria

1. *Rigid metal supply trunk line*

Design and install all duct systems using the “trunk and branch” configuration. The trunk and branch configuration requires that each HVAC system has at least one rigid supply trunk with multiple, short branch take-offs to each supply register.

2. *Space all supply duct take-offs ≥ 6 ” apart*

Space all supply duct take-offs at least 6” apart from each other with no duct take-offs originating from the cap of the supply plenum. Junction boxes with 4 take-offs or less and no take-off(s) directly opposite main supply to junction box are excluded.

3. *Install rigid circular duct as supply plenum from air handler*

To improve ductwork efficiency by reducing the duct leakage commonly found at the plenum board connection to the air handler. Seal all duct connections with mastic.

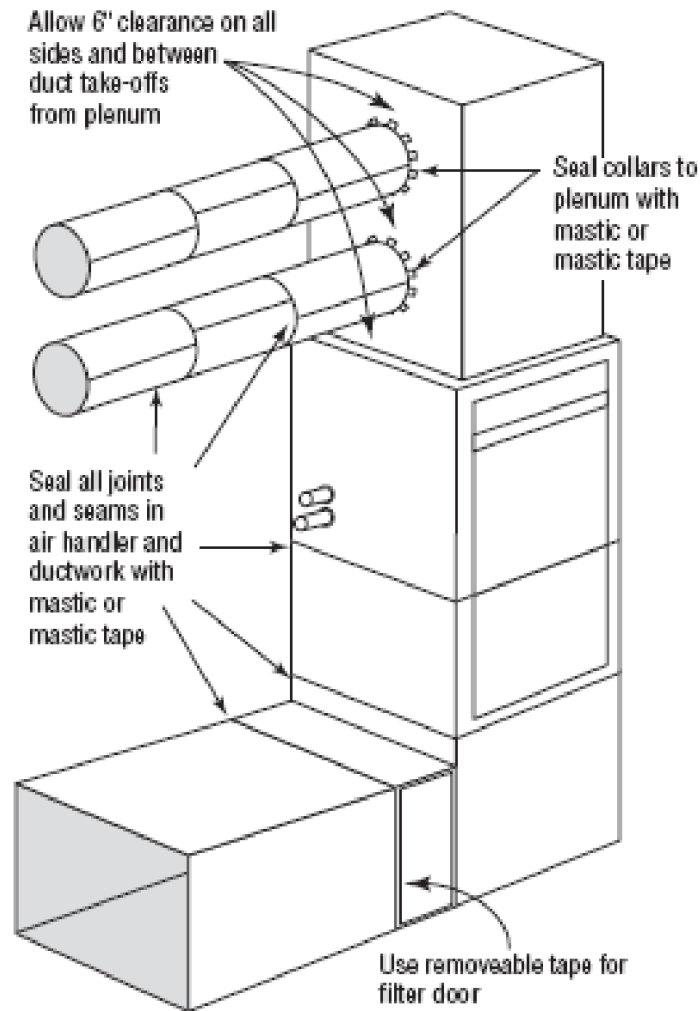

Figure 79: Duct installation at plenum

Confirmation

- The EarthCraft Technical Advisor will visually confirm compliance of criteria at pre-drywall and final inspections.

ES 2.18 Duct insulation in unconditioned spaces $\geq R-10$

Criteria

Insulate all ducts outside of conditioned spaces (e.g., in unconditioned attics, vented crawl spaces, and exterior locations) to R-10 insulation or greater.

Confirmation

- The EarthCraft Technical Advisor will visually confirm compliance of criteria at pre-drywall and final inspections.

ES 2.19 Return plenum duct take-off free area is 120% of supply plenum duct take-off free area

Criteria

Install all ductwork to provide capacity for at least 120% more return air than supply air for every system.

Exemptions

This line item is waived if the duct system is installed per Manual D.

Example

A 2-ton system with a 0.09 friction rate has the following flex duct supply take-offs:

Two 10" ducts = 570 cfm
One 8" duct = 160 cfm
One 6" duct = 75 cfm

805 cfm total supply side

To achieve a return capacity that is at least 120% of the supply capacity, the system would need the following flex duct return take-offs:

Two 10" ducts = 570 cfm
Two 8" ducts = 320 cfm
One 6" duct = 75 cfm

965 cfm total return side

Confirmation

- The EarthCraft Technical Advisor will visually confirm compliance of criteria at pre-drywall inspection.

Duct Leakage Test Results (ES 3)

ES 3.0 Test duct leakage based on conditioned floor area (CFA)

Criteria

1. *Leakage to outside* $\leq 4\%$

Duct blaster test result for leakage to outside is equal to or less than 4% of floor area served.

2. *Total leakage* $\leq 6\%$

Duct blaster test result for total leakage is equal to or less than 6% of floor area served.

Definitions

Duct leakage is calculated using the standard protocol set forth by RESNET for duct pressurization testing at 25 Pascals.

Duct leakage to outside is defined as the amount of duct leakage that leaves the building envelope and is tested separately from total duct leakage.

Total duct leakage is defined as the amount of total leakage that leaves the ducts.

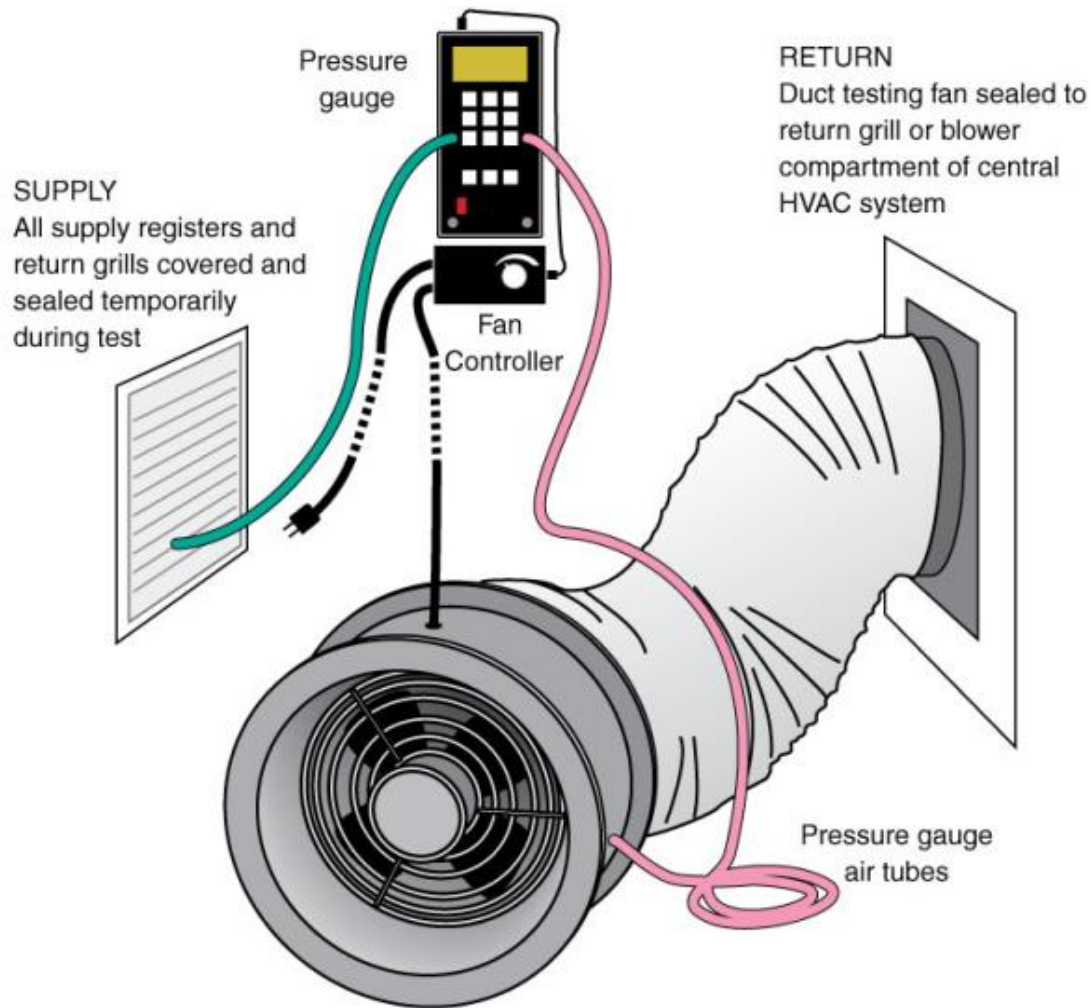

Figure 80: Duct leakage tester

Calculate duct leakage using the following formula:

$$\text{Duct Leakage} = \frac{\text{cfm}_{25}}{\text{square foot of floor area served}}$$

Where cfm_{25} is the volume of air in cubic feet per minute moved through the duct blaster fan to maintain a 25 Pa pressure difference between inside and outside of ductwork. Total duct leakage is the percentage of duct leakage for the entire duct system including the air handler, regardless of duct location.

Clarifications

Both the leakage to the outside and the total leakage duct tests apply to all HVAC systems, even those fully inside the building envelope of the unit or building.

Floor area must equal conditioned floor area used for the confirmed HERS energy model.

Rough-in test results may not be used to satisfy this requirement.

The air handler and all components of the supply and return duct work are included in the duct tests.

Example

A duct system that serves 2,000 sq ft of living space and has a total duct leakage at a 25 Pascal pressure difference of 240 cfm would have a duct leakage of 12%.

$$12\% \text{ leakage} = \frac{240 \text{ cfm}_{25}}{2,000 \text{ sq ft}}$$

Confirmation

- The EarthCraft Technical Advisor will diagnostically test compliance of criteria at the final inspection.

ES 3.1 Test duct leakage based on conditioned floor area (CFA)

Criteria

1. *Leakage to outside* $\leq 2\%$

Duct leakage test result for leakage to outside for each HVAC system is equal to or less than 2% of floor area served.

2. *Total leakage* $\leq 4\%$

Duct leakage test result for total leakage for each HVAC system is equal to or less than 4% of floor area served.

Clarifications

Both the leakage to the outside and the total leakage duct tests apply to all HVAC systems, even those fully inside the building envelope of the unit or building.

Floor area must equal conditioned floor area used for the confirmed HERS energy model.

Leakage rates are specific to each air handler and duct system and may not be averaged in units with multiple systems.

Rough-in test results may not be used to satisfy this requirement.

Confirmation

- The EarthCraft Technical Advisor will diagnostically test compliance of criteria at the final inspection.

Ventilation (ES 4)

ES 4.0 Install exhaust fans in all bathrooms and duct to outside

Criteria

Vent all bathroom exhaust fans to outdoors.

Clarifications

Any room with at least two of the following fixtures is considered a bathroom: sink, toilet, shower, tub, or urinal. Per ES 2.3 - Exhaust fan ductwork in full baths must be insulated.

Confirmation

- The EarthCraft Technical Advisor will visually confirm compliance with criteria at pre-drywall and final inspections.

ES 4.1 Gas kitchen range or cooktop vented to exterior with ≥ 100 cfm

Criteria

For each gas range or cooktop, install a kitchen exhaust fan (e.g., kitchen range or downdraft hood) and vent directly to the outdoors.

Kitchen exhaust fans must meet ASHRAE 62.2-2007 section 5 requirements. If exhausting continuously, fan must exhaust greater than 5 ACH, based on kitchen volume; if controlled by occupant to exhaust intermittently, fan must exhaust at least 100 cfm.

To ensure the installed fan exhausts the correct amount of cfm, kitchen exhaust fans must either be rated at a higher airflow than 100 cfm (minimum of 130 cfm on high setting) or have an installed measured airflow verified by a third-party ≥ 100 cfm and within 20% of the design rate.

Clarifications

Intentional make-up air must be provided for any kitchen vent fan rated at greater than 150 cfm so that total exhaust flow (makeup airflow minus fan rated exhaust) is no greater than 150 cfm.

The kitchen exhaust must be located within 5' of the range or cooktop.

Confirmation

Measured airflow fan (testing not required)

- The builder must present documentation demonstrating compliance with criteria to the EarthCraft Technical Advisor at the pre-drywall inspection.
- The EarthCraft Technical Advisor will review documentation provided by the builder for compliance with criteria.

OR

Third-party testing

- The EarthCraft Technical Advisor will diagnostically test for compliance with criteria at the final inspection.

ES 4.2 Outside air ventilation strategy complies with ASHRAE 62.2-2010

Criteria

Install outside air intake with ventilation cfm, mechanical damper, and controls meeting ASHRAE 62.2-2010. Exhaust only systems are not acceptable for meeting this requirement.

Ventilation system must have safe, accessible method for verifying air flow.

Provide information on type of system, maintenance, and monitoring requirements in project-specific owner's manual.

- *Intermittent ventilation with timer, manual flow damper, and electric shutoff damper*

Install outdoor air intake duct with a ventilation timer, manual flow damper and electric shutoff damper to the return side of each air handler to bring in outside air for ventilation.

Calculate flow rate according to [ASHRAE Standard 62.2-2010](#) for intermittent mechanical ventilation.

Designed and installed to operate at least once every 3 hours and at least 15% of the time (one hour out of every twelve).

The inlet must meet manufacturers' requirements for return air temperature (e.g., most manufacturers recommend a minimum of 60 °F airflow across furnace heat exchangers).

Intermittent ventilation systems that utilize the HVAC air handler must include a controller to regulate the ventilation run time by accounting for hours when HVAC systems are/are not heating or cooling.

- *Continuous ventilation*

Calculate flow rate according to [ASHRAE Standard 62.2-2010](#) for continuous mechanical ventilation.

Design continuous ventilation system to operate during all occupiable hours.

Continuous ventilation systems that utilize the HVAC air handler must install a fan motor type that shall be Electronically Commutated Motor/ Integrally Controlled Motor (ECM/ICM), variable speed, and run at a reduced speed during ventilation.

Clarifications

Floor area must equal conditioned floor area used for the confirmed HERS energy model. If code mandates a more stringent standard, that standard shall be followed and information concerning code approved flow rate must be provided to EarthCraft Project Manager at Design Review meeting.

Additional Resources

- [ASHRAE Standard 62.2-2010](#)
- [Whole-House Ventilation System Types](#) | [Whole-House Ventilation System Types](#) (Permalink)
- [Central Fan Integrated Ventilation Systems](#)

Confirmation

- The builder must submit documentation demonstrating compliance of criteria to the EarthCraft Project Manager prior to the Design Review.
- The EarthCraft Project Manager will review the strategy for compliance and confirm accessibility of ventilation flow rate testing during design review.
- The EarthCraft Technical Advisor will review documentation provided by the builder for compliance of criteria and will visually confirm compliance of criteria at final inspection.

ES 4.3 When installed, fresh air intakes must achieve the following standards:

Criteria

1. $\geq 10'$ away from exhaust outlets and vehicle idling zones

Locate air intakes for all building systems at least 10 feet away from any exhaust outlets, the parking lot and garage, and other areas where vehicle exhaust may be present. Air intake must pull air directly from outdoors and not from adjacent dwelling units, garages, unconditioned crawl spaces or attics.

2. ≥ 2 above grade

Locate air intakes 2 feet above finished grade.

3. When run to the soffit, the duct must be extended and affixed through soffit vent.
If running fresh air through the soffit, it must extend and be affixed all the way through the soffit vent and may not terminate and rest on top of the soffit.

4. Fresh air duct may not be run to the roof

Do not run fresh air to the roof of the structure. Exception: Dedicated Outdoor Air System (DOAS) located on a surface that does not have asphalt shingles.

5. Fresh air shutoff may not be controlled by humidistat

If using a fresh air shutoff, it cannot be controlled by the humidistat.

6. Install rigid duct with insulation

When ducting the fresh air into a unit, use rigid duct work with insulation that meets at least code minimum. All duct work, including ducts in conditioned space, must be insulated.

7. All intakes must be ducted to the exterior of the building

Locate air intakes for all building systems outside of the building shell.

Clarifications

Air intakes include intakes for closed-system combustion equipment, outdoor ventilation air supply, etc., and exhaust outlets include bathroom exhaust fans, range hood exhaust fan outlet, dryer exhaust, combustion exhaust, radon vent, etc.

Design air-intake locations to minimize obstruction by snow, plantings, condensing units or other material.

Only air intakes used specifically for combustion air are permitted on rooftops.

Ventilation inlet screens can become clogged with debris over time, therefore EarthCraft recommends, but does not require, that builders locate inlets to facilitate access and regular service by the maintenance staff.

Confirmation

- The EarthCraft Technical Advisor will visually confirm compliance with criteria at pre-drywall and final inspections.

ES 4.4 Seal seams of all intake and exhaust ducts with mastic

Criteria

Mastic paste must be used on the sealing of all ducts. Coat duct seams and connections with layer of mastic paste covering seams by 1.5" on both sides and as thick as a nickel.

Confirmation

- The EarthCraft Technical Advisor will visually confirm compliance with criteria at pre-drywall inspection.

ES 4.5 Duct clothes dryers to outside

Criteria

All clothes dryers must be ducted to the outside.

Clarifications

For electric condensing dryers, plumb condensate to a drain according to manufacturer instructions.

Confirmation

- The EarthCraft Technical Advisor will visually confirm compliance with criteria at pre-drywall and final inspections.

ES 4.6 No power roof vents

Criteria

Do not install electrically powered or solar-powered attic exhaust vents.

Confirmation

- The EarthCraft Technical Advisor will visually confirm compliance with criteria at pre-drywall and final inspections.

ES 4.7 Back-draft dampers for kitchen, bathroom, and dryer exhausts

Criteria

Install back-draft dampers for all individual exhaust fans and exhaust fans sharing a common exhaust.

Clarifications

Common exhausts may not be shared by fans in separate dwelling units (e.g., townhomes).

Confirmation

- The EarthCraft Technical Advisor will visually confirm compliance with criteria at pre-drywall inspection.

ES 4.8 If installed, ceiling fans must be ENERGY STAR qualified

Criteria

If installed, all ceiling fans must be ENERGY STAR qualified.

Clarifications

As products and ENERGY STAR qualifications are periodically updated, the product must be on the list of ENERGY STAR qualified products at the time it was purchased.

Additional Resources

- A list of qualified products can be found at:
<https://www.energystar.gov/productfinder/>

Confirmation

- The builder must submit documentation demonstrating compliance with criteria to the EarthCraft Technical Advisor at the final inspection.
- The EarthCraft Technical Advisor will review documentation provided by the builder for compliance with criteria and will visually confirm compliance with criteria at final inspection.

ES 4.9 ENERGY STAR bath fans with properly sized ductwork and measured airflow ≥ 50 cfm

Criteria

All bathroom ventilation fans must be ENERGY STAR qualified with properly sized ductwork and measured airflow ≥ 50 cfm.

To ensure the installed fan exhausts the correct amount of cfm, bath fans must either be rated at a higher airflow than 50 cfm (minimum 70 cfm rating) or have an installed measured airflow verified by a third-party ≥ 50 cfm.

Clarifications

As products and ENERGY STAR qualifications are periodically updated, the product must be on the list of ENERGY STAR qualified products at the time it was purchased.

Bath fans that run continuously must have measured airflow verified by a third-party > 20 cfm.

Additional Resources

- A list of qualified products can be found at:
<https://www.energystar.gov/productfinder/>

Exemptions

Multi-port fans exhausting multiple bathrooms and bath fans with a flow rate greater than or equal to 500 cfm also qualify as meeting these criteria.

Confirmation

Measured airflow fan (testing not required)

- The builder must present documentation demonstrating compliance with criteria to the EarthCraft Technical Advisor at the pre-drywall inspection.
- The EarthCraft Technical Advisor will review documentation provided by the builder for compliance with criteria.

OR

Third party-testing

- The EarthCraft Technical Advisor will diagnostically test for compliance with criteria at the final inspection.

ES 4.10 Vent kitchen exhaust fans to exterior ≥ 100 cfm: electric ranges

Criteria

For each electric range, install a kitchen exhaust fan (e.g., kitchen range or downdraft hood) and vent directly to the outdoors.

Kitchen exhaust fans must meet ASHRAE 62.2 section 5 requirements. If exhausting continuously, fan must exhaust greater than 5 ACH, based on kitchen volume, if controlled by occupant to exhaust intermittently, fan must exhaust at least 100 cfm.

To ensure the installed fan exhausts the correct amount of cfm, kitchen exhaust fans must either be rated at a higher airflow than 100 cfm (minimum of 130 cfm on high setting) or have an installed measured airflow verified by a third-party ≥ 100 cfm and within 15% of the design rate.

Clarifications

Intentional make-up air must be provided for any kitchen vent fan rated at greater than 150 cfm so that total exhaust flow (makeup airflow minus fan rated exhaust) is no greater than 150 cfm.

The kitchen exhaust must be located within 5' of the range or cooktop.

Confirmation

Measured airflow fan (testing not required)

- The builder must present documentation demonstrating compliance of criteria to the EarthCraft Technical Advisor at the pre-drywall inspection.
- The EarthCraft Technical Advisor will review documentation provided by the builder for compliance of criteria.

OR

Third party testing

- The EarthCraft Technical Advisor will diagnostically test compliance of criteria at the final inspection.

ES 4.11 Verify outdoor air supply ventilation airflow test within +/- 20% of design values

Criteria

Measure ventilation rates to be within +/- 20% of design rate.

Clarification

Comply with ES 4.2 and ensure adequate access for testing ventilation air flow.

Confirmation

- The EarthCraft Technical Advisor will diagnostically test compliance of criteria at the final inspection.

ES 4.12 Install and label accessible ventilation controls, with override controls for continuously operating ventilation fans

Criteria

Label ventilation controls unless function is obvious (e.g., bathroom exhaust fan).

Clarifications

Include readily accessible override controls for continuously operating ventilation and exhaust fans (e.g., ERVs and other outdoor air supply ventilation systems).

Confirmation

- The EarthCraft Technical Advisor will visually confirm compliance of criteria at final inspection.

ES 4.13 Supply and exhaust fans rated at ≤ 3 sones (intermittent) and ≤ 1 sone (continuous)

Criteria

Install intermittent supply and exhaust fans that are rated at less than 3 sones by manufacturer, unless rated flow is greater than 400 cfm.

Install continuous supply and exhaust fans that are rated at less than 1 sone by manufacturer.

Clarifications

HVAC and remote-mounted fans (i.e., fans with 4 ft. or more of ductwork between the fan and intake grill and outside of habitable spaces, bathrooms, toilets, and hallways) are exempt from these requirements.

Kitchen range hoods are considered an exhaust fan.

Additional resources

- The Home Ventilating Institute (HVI) maintains a list of products with tested sone ratings: <https://www.hvi.org/hvi-certified-products-directory/section-i-complete-product-listing/>

Confirmation

- The EarthCraft Technical Advisor will visually confirm compliance of criteria at pre-drywall inspection.

ES 4.14 Radon resistant construction

Criteria

1. *Passive, labeled radon/soil gas system*

Install a passive radon vent system in compliance with EPA's "Building Radon Out".

2. *Radon test of Building prior to occupancy*

Test building for radon prior to occupancy according to EPA testing procedures. Disclose test results to potential occupants. Test all 1st floor units and a minimum of 10% of units on upper floors.

OR

Provide two radon test kits designed for 48-hour exposures to the occupant(s), including test kit instructions and EPA guidance on follow-up actions to be taken in response to the test results.

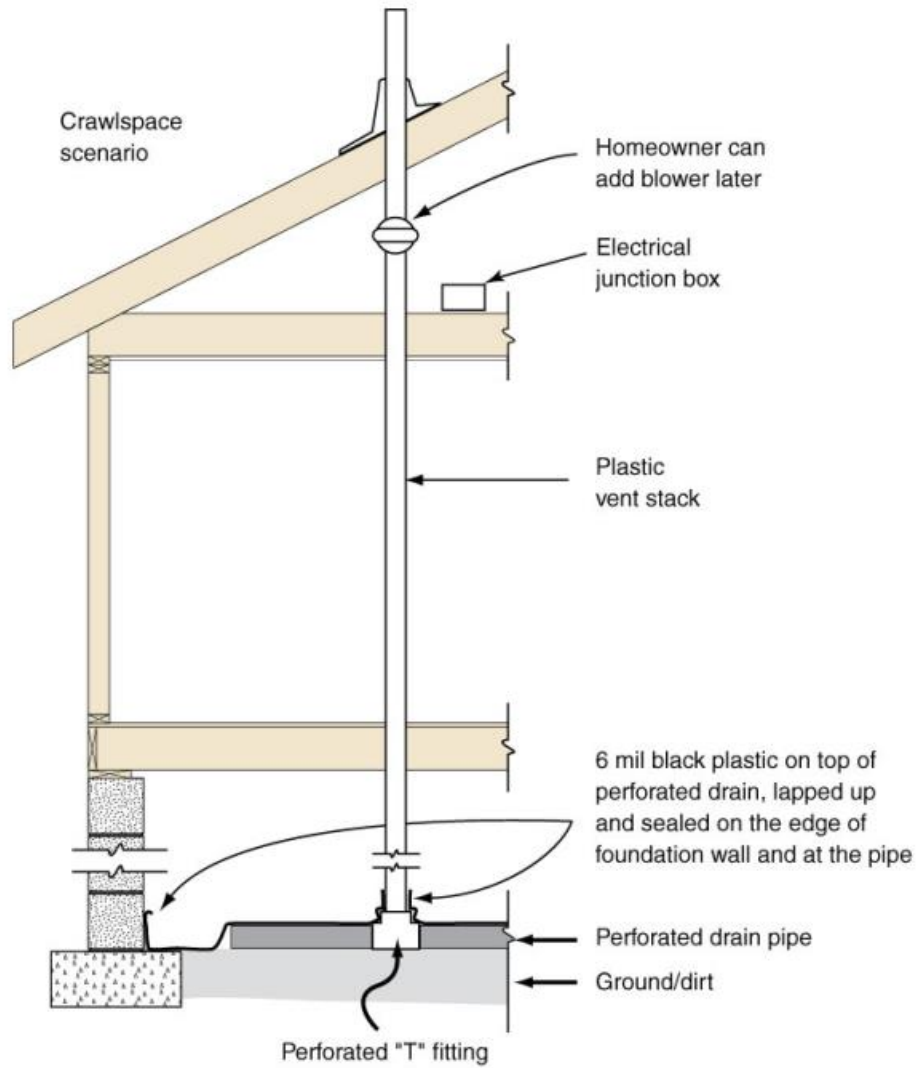

Figure 81: Radon vent pipe

Clarifications
 Projects in all radon zones must comply.

Additional resources

- [EPA's "Building Radon Out" | EPA's "Building Radon Out"](#) (Permalink)
- [ANSI/AARST MAMF-2017: Protocol for Conducting Measurements of Radon and Radon Decay Products in Multifamily Buildings](#)

Confirmation

- The EarthCraft Technical Advisor will visually confirm compliance of criteria at pre-drywall and final inspections.

ES 4.15 Exhaust fan wired with light in bathroom

Criteria

Bath fan must be wired to the lighting system in the bathroom to encourage proper ventilation.

Confirmation

- The EarthCraft Technical Advisor will visually confirm compliance with criteria at final inspection.

ES 4.16 Duct all exhaust fans with rigid duct

Criteria

Duct all exhaust fans with rigid duct material and seal connections with mastic or mastic tape.

Confirmation

- The EarthCraft Technical Advisor will visually confirm compliance of criteria at pre-drywall inspection.

ES 4.17 Automatic bathroom exhaust fan controls

Criteria

Install either a timer, occupancy sensor, or humidity control (i.e., a humidistat) for all bath fans installed in rooms with tubs, showers or similar sources of moisture. Include instructions for using controls in occupant manual.

Provide information on type of system, maintenance, and monitoring requirements in project-specific owner's manual.

Confirmation

- The EarthCraft Technical Advisor will visually confirm compliance of criteria at final inspection.

ES 4.18 Energy recovery ventilator

Criteria

Install an Energy Recovery Ventilator (ERV) according to the manufacturer's specifications and meeting ASHRAE 62.2-2010 for ventilation flow rate.

Confirmation

- The EarthCraft Technical Advisor will visually confirm compliance of criteria at pre-drywall inspection.

ES 4.19 Vent storage room to outside

Criteria

Provide a separate storage room in the garage with a lockable door vented directly to the outdoors with a minimum of 100 square inches of net free vent area per 100 square feet of floor area.

Clarifications

No combustion equipment or HVAC equipment may be installed in the storage room.

Confirmation

- The EarthCraft Technical Advisor will visually confirm compliance of criteria at final inspection.

Water Heater (ES 5)

ES 5.0 If gas, direct vent

Criteria

If installing a gas water heater it must be directly vented to the exterior and bring in combustion air from the exterior.

Clarification

To meet IAQ 1.3, the water heater must be installed in conditioned space.

Confirmation

- The EarthCraft Technical Advisor will visually confirm compliance of criteria at final inspection.

ES 5.1 Heat trap on storage water heaters

Criteria

If installing storage water heater, either purchase storage water heater with heat trap installed or install heat trap on storage water heater.

Confirmation

- The EarthCraft Technical Advisor will visually confirm compliance of criteria at final inspection.

ES 5.2 Water Heater Efficiencies:

Criteria

Install storage water heater that meets the energy factor (EF) or Uniform Energy Factor (UEF) requirements in the following table for gas or electric operation:

Tank Size	Gas EF	Electric EF	Gas UEF	Electric UEF
20- 55 gal	0.65	0.95	0.61	0.92
55- 100 gal	0.75	1.97	0.76	2.03
< 2 gal	0.82	0.93	0.81	0.91

Clarification

To meet IAQ 1.3, the water heater must be installed in conditioned space.

Confirmation

- AHRI Certificate provided to Technical Advisor
- The EarthCraft Technical Advisor will visually confirm compliance of criteria at final inspection.

ES 5.3 Pipe insulation on first 2'

Criteria

Water heater must have pipe insulation on the first 2' of hot water supply pipe.

Confirmation

- The EarthCraft Technical Advisor will visually confirm compliance of criteria at final inspection

ES 5.4 High efficiency storage water heater

Criteria

Install storage water heater that meets the energy factor (EF) or Uniform Energy Factor (UEF) requirements in the following table for gas or electric operation:

Tank Size	Gas EF	Electric EF	Gas UEF	Electric UEF
≤55 gallon	≥0.67	≥2.00	≥0.64	≥2.00
>55 gallon	≥0.77	≥2.20	≥0.78	≥2.20

Confirmation

- The EarthCraft Technical Advisor will visually confirm compliance of criteria at final inspection.

ES 5.5 Tankless gas water heater ≥ .90 EF or ≥ .87 UEF

Criteria

Install tankless water heater according to manufacturer's specifications that meets or exceeds .90 EF energy factor (EF) or .87 Uniform Energy Factor (UEF)

Confirmation

- The builder must present documentation demonstrating compliance of criteria to the EarthCraft Technical Advisor at the final inspection.
- The EarthCraft Technical Advisor will review documentation provided by the builder for compliance of criteria and will visually confirm compliance of criteria at final inspection.

ES 5.6 Type of water heater

Criteria

A. Solar domestic (≥40% of annual load)

Install a solar domestic water heater according to manufacturer specifications to handle a minimum of 40% of the annual water-heating load.

B. High efficiency tankless water heater with insulated buffer tank

Install a tankless gas water heater according to manufacturer specifications that meets a minimum of 0.92 Energy Factor or .89 UEF with an insulated buffer tank to reduce water wasted while tankless water heater ramps up to desired hot water temperature.

C. ENERGY STAR qualified heat pump

Install ENERGY STAR heat pump water heater with a minimum Energy Factor or UEF of 2.0 and according to manufacturer's specifications.

OR

Install heat recovery water heating (refrigerant-to-water desuperheating coil) according to manufacturer specifications to recover waste heat from an air conditioner or heat pump to heat domestic water.

Clarifications

As products and ENERGY STAR qualifications are periodically updated, the product must be on the list of ENERGY STAR qualified products at the time it was purchased.

Additional Resources

- A list of qualified products can be found at:
<https://www.energystar.gov/productfinder/>

Confirmation

- The builder must present documentation demonstrating compliance of criteria to the EarthCraft Technical Advisor at the final inspection.
- The EarthCraft Technical Advisor will review documentation provided by the builder for compliance of criteria and will visually confirm compliance of criteria at final inspection.

ES 5.7 Hot water pipe insulation \geq R-4 (100%)

Criteria

Insulate all hot water pipes to R-4 or greater using polyethylene, neoprene, fiberglass or other insulation types. Fit insulation tightly around hot water pipe, face seam down, and secure insulation every 2 feet using wire, tape or clamp. Install insulation on all piping elbows to adequately insulate 90-degree bend.

Exemptions

Hydronic heating systems are not required to insulate pipes in slabs or other approved materials intended for radiating heat into conditioned space and therefore do not apply to this criteria.

Confirmation

- The EarthCraft Technical Advisor will visually confirm compliance of criteria at pre-drywall inspection.

Lighting and Appliances (ES 6)

ES 6.0 High-efficacy lighting in 100% of all permanent fixtures

Criteria

Install high-efficacy lighting in 100% or more of all permanent fixtures. High efficacy lighting includes compact fluorescent bulbs, T-8 or smaller diameter linear fluorescent bulbs, or bulbs with a minimum efficacy of:

- 60 lumens per watt for bulbs over 40 watts
- 50 lumens per watt for bulbs from 15 watts to 40 watts
- 40 lumens per watt for bulbs 15 watts or less

Confirmation

- The EarthCraft Technical Advisor will visually confirm compliance of criteria at final inspection.

ES 6.1 If installed, ENERGY STAR dishwasher

Criteria

All installed dishwashers must be ENERGY STAR qualified.

Clarifications

As products and ENERGY STAR qualifications are periodically updated, the product must be on the list of ENERGY STAR qualified products at the time it was purchased.

Additional Resources

- A list of qualified products can be found at:
<https://www.energystar.gov/productfinder/>

Confirmation

- The builder must present documentation demonstrating compliance of criteria to the EarthCraft Technical Advisor at the final inspection.
- The EarthCraft Technical Advisor will review documentation provided by the builder for compliance of criteria and will visually confirm compliance of criteria at final inspection.

ES 6.2 If installed, ENERGY STAR refrigerator

Criteria

All installed refrigerators must be ENERGY STAR qualified.

Clarifications

As products and ENERGY STAR qualifications are periodically updated, the product must be on the list of ENERGY STAR qualified products at the time it was purchased.

Additional Resources

- A list of qualified products can be found at:
<https://www.energystar.gov/productfinder/>

Confirmation

- The builder must present documentation demonstrating compliance of criteria to the EarthCraft Technical Advisor at the final inspection.
- The EarthCraft Technical Advisor will review documentation provided by the builder for compliance of criteria and will visually confirm compliance of criteria at final inspection.

ES 6.3 If installed, ENERGY STAR qualified clothes washer

Criteria

If installed, all installed clothes washers must be ENERGY STAR qualified.

Clarifications

This item applies to both dwelling units when laundry equipment is provided as well as central laundry locations. It applies to both owned and leased central laundry equipment. As products and ENERGY STAR qualifications are periodically updated, the product must be on the list of ENERGY STAR qualified products at the time it was purchased.

Additional Resources

- A list of qualified products can be found at:
<https://www.energystar.gov/productfinder/>

Confirmation

- The builder must present documentation demonstrating compliance with criteria to the EarthCraft Technical Advisor prior to the final inspection.

ES 6.4 If installed, High Efficiency clothes dryer with moisture sensor

Criteria

If installed, all clothes dryers must be high efficiency with moisture sensors. Dryers should be ENERGY STAR labeled or meet or exceed the CEF for their type in the table below.

Dryer Type	CEF
Vented Gas	3.48
Ventless or Vented Electric, Standard (4.4 cu-ft or greater capacity)	3.93
Ventless or Vented Electric, Compact (120V) (less than 4.4 cu-ft capacity)	3.80
Vented Electric, Compact (240V) (less than 4.4 cu-ft capacity)	3.45
Ventless Electric, Compact (240 V) (less than 4.4 cu-ft capacity)	2.68

Clarifications

This item applies to dwelling units only and is not applicable for central laundry locations. As products and qualifications are periodically updated, the product must be on the list of qualified products at the time it was purchased.

Additional Resources

- Product CEFs can be verified at the following website:
<https://cacertappliances.energy.ca.gov/Pages/ApplianceSearch.aspx>
- <https://www.energystar.gov/productfinder/product/certified-clothes-dryers/>

Confirmation

- The builder must present documentation demonstrating compliance with criteria to the EarthCraft Technical Advisor prior to the final inspection.

ES 6.5 Fixtures and bulbs

Criteria

- A. *ENERGY STAR qualified compact fluorescent fixtures or LED bulbs (100%)*

Install ENERGY STAR qualified compact fluorescent fixtures or LED screw-in bulbs for 100% of all interior lighting.

B. Ballasted compact fluorescent fixtures or LED bulbs at all recessed light fixtures

Install ballasted compact fluorescent fixtures or ENERGY STAR qualified LEDs in all recessed light fixtures.

Clarifications

Projects may use a combination of fixtures and bulbs outlined in A & B but can receive credit only on the lower pointed item.

Bulbs in appliances (refrigerators, ovens, etc.) are excluded from the bulb percentage count.

As products and ENERGY STAR qualifications are periodically updated, the product must be on the list of ENERGY STAR qualified products at the time it was purchased.

Additional Resources

- A list of qualified products can be found at:
<https://www.energystar.gov/productfinder/>.

Example

A project with 20% ENERGY STAR qualified compact fluorescent fixtures and 70% ENERGY STAR qualified screw-in compact fluorescent bulbs would qualify for B.

Confirmation

- The EarthCraft Technical Advisor will visually confirm compliance with criteria at final inspection.

Common Area Lighting/Appliances (ES 7)

ES 7.0 Ballasted compact fluorescents and/or LED bulbs in all corridor/ breezeway and all common spaces

Criteria

All lighting in corridor/breezeway and all common spaces must be ballasted compact fluorescents and/or LED bulbs. It can be a combination of both types but must comprise 100 percent of the lighting installed.

Confirmation

- The EarthCraft Technical Advisor will visually confirm compliance with criteria prior to the final inspection.

ES 7.1 Control systems

Criteria

1. *Automatic indoor lighting controls*

All kitchens, bathrooms, hallways, closets, and utility rooms must have an automatic lighting control system such as a vacancy sensor or timer with manual-on control.

2. *Automatic outdoor lighting controls*

Control exterior lighting with automatic motion or timer controls that incorporate a photocell to prevent daytime use.

Confirmation

- The EarthCraft Technical Advisor will visually confirm compliance with criteria at final inspection.

ES 7.2 High-efficiency exterior lighting:

Criteria

Reduce high energy use in exterior lighting environments through improved design practices. The lighting design must account for the following elements:

1. Exterior lighting for walkways and other pedestrian paths;
2. Exterior lighting for parking area lighting;
3. Design must include exterior lighting mounted to the building (wall packs), tenant porch lighting, and lighting at the building entrance/site entrance;
4. To achieve this credit, down lighting controls must be included on all exterior light fixtures (Dark Sky Compliant);
5. Lighting shutoff controls must be included at all possible locations (porches, site, and building).

1. *Design to reach IES guidelines: Lighting for Exterior Environments*

Outdoor Lighting must meet IES guidelines (IESNA publication, RP-33-1999).

2. *Achieve 50% reduction based on Advanced Energy Design Guide (ASHRAE/IES)*

Outdoor lighting must meet the 50% reduction based on the Advanced Energy Design Guide. (ASHRAE/IES publication, Advanced Energy Design Guide for Small to Medium Office Buildings)

3. *High-efficiency lighting using 100% fluorescent and/or LED bulbs*

Outdoor lighting must use 100% fluorescent and/or LED bulbs.

Additional Resources

- A list of qualified outdoor lighting products can be found at: <https://www.energystar.gov/productfinder/> and <http://www.darksky.org/outdoorlighting>.
- Design guidelines can be located at: www.ies.org and www.ashrae.org.

Confirmation

- The lighting designer must present documentation demonstrating compliance with criteria to the EarthCraft Technical Advisor prior to the final inspection.
- The EarthCraft Technical Advisor will review documentation provided by the project team for compliance with criteria and will visually confirm compliance with criteria at final inspection.

ES 7.3 High-efficiency elevators

Criteria

Elevators installed must meet efficiency criteria of Traction (ThyssenKrupp), MRL (Machine Room-Less), or equivalent elevator systems.

Confirmation

- The EarthCraft Technical Advisor will review documentation provided by the project team for compliance with criteria and will visually confirm compliance with criteria at final inspection.

Water Efficiency (WE)

Indoor Water Use (WE 1)

WE 1.0 Meet National Energy Policy Act low-flow standards for all fixtures

Criteria

All fixtures must meet the National Energy Policy Act low-flow standards for flow requirements.

Confirmation

- The EarthCraft Technical Advisor will visually confirm compliance with criteria at final inspection.

WE 1.1 Detect no leaks at any water-using fixture, appliance or equipment

Criteria

There must be no detected leaks from any water-using fixture, appliance or equipment as determined by pressure-loss testing and visual inspections.

Confirmation

- The EarthCraft Technical Advisor will visually confirm compliance of criteria at final inspection.

WE 1.2 Low-flow fixtures (units and common facilities)

Criteria

1. *WaterSense labeled toilet (≤ 1.28 avg. gal/flush)*

All installed toilets must be WaterSense labeled with an average maximum gallon per flush of 1.28 or less.

2. *WaterSense labeled urinal (≤ 0.5 gal/flush)*

All installed urinals must be WaterSense labeled with an average maximum gallon per flush of 0.5 or less.

3. *WaterSense labeled lavatory faucet and accessories (≤ 1.5 gpm at 60 psi)*

All installed bathroom sink faucets and accessories must be WaterSense labeled with an average maximum gallon per minute of 1.5 or less at 60 psi.

4. *WaterSense labeled Showerhead (≤ 2 gpm)*

All installed showerheads must be WaterSense labeled with an average maximum flow rate of 2 gallons per minute.

Clarifications

Dual-flush toilet average flush rates should be calculated as follows: (2 low flush + 1 high flush)/3.

Additional Resources

- WaterSense Labeled Fixtures: <https://www.epa.gov/watersense/watersense-products>

Confirmation

- The builder must present documentation demonstrating compliance of criteria to the EarthCraft Technical Advisor at the final inspection.
- The EarthCraft Technical Advisor will review documentation provided by the builder for compliance of criteria at final inspection.

WE 1.3 If installed, water treatment system NSF certified, \geq 85% efficient

Criteria

Any installed drinking water systems must be certified to meet applicable NSF/ANSI standards with a minimum of 85% efficiency rating:

- NSF/ANSI 42 Drinking Water Treatment Units - Aesthetic Effects
- NSF/ANSI 53 Drinking Water Treatment Units - Health Effects
- NSF/ANSI 55 Ultraviolet Microbiological Water Treatment Systems
- NSF/ANSI 58 Reverse Osmosis Drinking Water Treatment Systems
- NSF/ANSI 62 Drinking Water Distillation Systems.

Each system must yield 85 gallons or greater of treated water for each 100 gallons of water processed.

Confirmation

- The project team must present documentation demonstrating compliance with criteria to the EarthCraft Technical Advisor prior to the final inspection.
- The EarthCraft Technical Advisor will review documentation provided by the project team for compliance with criteria and will visually confirm compliance with criteria at final inspection.

WE 1.4 If installed, water softeners certified to NSF/ANSI Standard 44

Criteria

Any installed self-regenerating water softeners must be certified to meet NSF/ANSI 44 Residential Cation Exchange Water Softeners, including the voluntary efficiency rating standards in Section 7 - Mandatory testing for elective claims for efficiency rated systems. These standards state that water softeners must:

- Be a demand-initiated regeneration system (i.e., it must use a flow meter or water hardness sensor to initiate regeneration; devices that use time clock-initiated regeneration [fixed time schedule] do not qualify for the efficiency rating).
- Have a rated salt efficiency of not less than 3,350 grains of total hardness exchange per pound of salt, based on sodium chloride (NaCl) equivalency (477 grams of total hardness exchange per kilogram of salt).
- Not generate more than 5 gallons of water per 1,000 grains of hardness removed during the service cycle (18.9 liters per 64.8 grams of total hardness removed).

Confirmation

- The project team must present documentation demonstrating compliance with criteria to the EarthCraft Technical Advisor prior to the final inspection.
- The EarthCraft Technical Advisor will review documentation provided by the project team for compliance with criteria and will visually confirm compliance with criteria at final inspection.

WE 1.5 Store \leq 0.5 gal of water between water heater and fixture

Criteria

The hot water distribution system must store no more than 0.5 gallons of water in any piping/manifold between the hot water source and any hot water fixture.

To account for the additional water that must be removed from the system before hot water can be delivered, no more than 0.6 gallons of water must be collected from the hot water fixture before hot (105°F) water is delivered.

Clarifications

If a circulation system is used, it must be on-demand circulation. Continuous circulation systems and circulation systems with timers are not approved methods. This credit is not applicable to central water heating systems.

Project teams are encouraged to design systems to store less than 0.35 gallons of water in any piping/manifold between the hot water source and any hot water fixture to ensure no more than 0.6 gallons of water are collected from the hot water fixture before hot water is delivered.

MAXIMUM LENGTH OF PIPE OR TUBE

<u>Nominal Pipe or Tube Size (inch)</u>	<u>Liquid Ounces per Foot of Length</u>	<u>Maximum Pipe or Tube Length</u>	
		<u>System without a Circulation Loop or Heat Traced Line (feet)</u>	<u>System with a Circulation Loop or Heat Traced Line (feet)</u>
1/4 ^a	0.33	50	16
5/16 ^a	0.5	50	16
3/8 ^a	0.75	50	16
1/2	1.5	43	16
5/8	2	32	12
3/4	3	21	8
7/8	4	16	6
1	5	13	5
1 1/4	8	8	3
1 1/2	11	6	2
2 or larger	18	4	1

a. The flow rate for 1/4 inch size is limited to 0.5 gpm; for 5/16 inch size is limited to 1 gpm; for 3/8 inch size is limited to 1.5 gpm.

Table provided by Gary Klein

Confirmation

- The project team must present documentation demonstrating compliance with criteria to the EarthCraft Technical Advisor at the pre-drywall inspection.

WE 1.6 WaterSense labeled showerhead (1.75gpm)

Criteria

All installed showerheads must be WaterSense labeled with an average maximum flow rate of 1.75 gallons per minute.

Additional Resources

- <https://www.epa.gov/watersense/showerheads>

Confirmation

- The builder must present documentation demonstrating compliance of criteria to the EarthCraft Technical Advisor at the final inspection.
- The EarthCraft Technical Advisor will review documentation provided by the builder for compliance of criteria at final inspection.

WE 1.7 Toilet (\leq 1.1 avg gal/flush)

Criteria

All installed toilets must have an average maximum gallon per flush of 1.1 or less.

Clarifications

Dual flush toilet average flush rates should be calculated as follows: (2 low flush + 1 high flush)/3.

Confirmation

- The builder must present documentation demonstrating compliance of criteria to the EarthCraft Technical Advisor at the final inspection.
- The EarthCraft Technical Advisor will review documentation provided by the builder for compliance of criteria at final inspection.

WE 1.8 Waterless urinals in common areas, all fixtures

Criteria

All urinals installed in common areas must be waterless.

Confirmation

- The EarthCraft Technical Advisor will visually confirm compliance of criteria at final inspection.

WE 1.9 Greywater system for toilet flushing

Criteria

Install greywater system designed to capture, at a minimum, the greywater from the master shower and be reused for flushing the master toilet.

Clarifications

Any installed greywater system must comply with any and all applicable state and local laws.

Confirmation

- The EarthCraft Technical Advisor will visually confirm compliance of criteria at final inspection.

WE 1.10 Rainwater harvest system for indoor water use

Criteria

Install rainwater harvest system with minimum capacity to flush at least one primary toilet in each dwelling unit or wash clothes.

Clarifications

Any installed rainwater system must comply with any and all applicable state and local laws.

Confirmation

- The EarthCraft Technical Advisor will visually confirm compliance of criteria at final inspection.

WE 1.11 Unit water pressure ≤ 60 psi

Criteria

The static service pressure in a unit must be equal to or less than 60 pounds per square inch (psi).

Clarifications

Units supplied by a municipal water supply must either use pressure regulating valve (PRV) upstream of all fixture connections or provide documentation from the public water supplier stating that water pressure will not exceed 60 psi. Units supplied by groundwater wells must meet this requirement by installing a pressure tank.

Exemptions

Piping for unit fire sprinkler systems is excluded from this requirement and should comply with state and local codes and regulations.

<https://codes.iccsafe.org/public/document/code/550/9793989>

Confirmation

Pressure regulating valve

- The EarthCraft Technical Advisor will visually confirm compliance with criteria at final inspection.

Public water supplier

- The Project team must submit documentation demonstrating compliance with criteria at Design Review meeting.
- The EarthCraft Technical Advisor will review documentation provided by the project team for compliance with criteria.

WE 1.12 Hot water demand ≤ 0.13 gal of water between loop and fixture and ≤ 2 gal of water in loop between water heater and furthest fixture

Criteria

Install a demand controlled hot water priming loop such that the volume from the loop to the hot water outlets is 0.13 gallons or less.

Zone the hot water distribution system so that volume in one or more demand controlled priming loops is kept to less than 2 gallons from the water heater to the furthest fixture on the loop.

Install buttons or motion sensors, either wired or wireless, in each hot water location to activate pump(s).

Meet the installation procedures in ES 5.4 for pipe insulation.

Clarifications

For pipe lengths to volume conversion, see Maximum Length of Pipe or Tube table under WE 1.4.

Confirmation

- The builder must present documentation demonstrating compliance of criteria to the EarthCraft Technical Advisor at the pre-drywall inspection.
- The EarthCraft Technical Advisor will review documentation provided by the builder for compliance of criteria and will visually confirm compliance of criteria at pre-drywall inspection and test compliance at final inspection.

Outdoor Water Use (ES 2)

WE 2.0 Cover all exposed soil with 2"-3" mulch layer

Criteria

Install mulch to cover planting beds with at least 2 inches but no more than 3 inches of mulch during landscaping installation.

Confirmation

- The EarthCraft Technical Advisor will visually confirm compliance of criteria at final inspection.

WE 2.1 If installed, irrigation system

Criteria

1. *Must have rain sensor shutoff switch*

Irrigation systems must be equipped with technology (either a rain sensor or soil moisture sensor) that inhibits or interrupts operation of the irrigation system during periods of rainfall or sufficient soil moisture.

2. *Provide operating manual to property management*

The builder must develop and provide property management a written operating and maintenance manual for all water-using equipment or controls installed in the house or yard, including all relevant WaterSense materials on indoor and outdoor water use. This may be a chapter or folder in an existing manual.

3. *Provide irrigation system layout to property management*

The builder must provide irrigation system layout to property management.

Confirmation

Rain sensor shutoff switch

- The EarthCraft Technical Advisor will verbally and visually confirm compliance of criteria with the builder at the final inspection.

Manual

- The builder must present documentation demonstrating compliance of criteria to the EarthCraft Technical Advisor at the final inspection.
- The EarthCraft Technical Advisor will review documentation provided by the builder for compliance of criteria.

WE 2.2 If installed, ornamental water features must recirculate water and serve beneficial use

Criteria

Install ornamental water feature that recirculates water from the feature itself and serve a beneficial use.

Provide information on type of system, maintenance, and monitoring requirements in project-specific owner's manual.

Clarifications

Beneficial uses include wildlife habitat, stormwater management and/or noise reduction.

Confirmation

- The EarthCraft Technical Advisor will visually confirm compliance of criteria at final inspection.

WE 2.3 Install plants to maintain $\geq 2'$ distance from building at maturity

Criteria

Locate all bushes, shrubs, trees, vines, and other vegetation so that at maturity the plantings are $\geq 2'$ from the building exterior.

Clarifications

In order to meet the 2' spacing requirement at maturity, most plants will need to be greater than 2' from the building at the time of the final inspection.

Measurement is from the closest edge of the plant foliage to the building, not the center or stem of the plant.

Confirmation

- The EarthCraft Technical Advisor will verbally and visually confirm compliance of criteria with the builder at the final inspection.

WE 2.4 Turf $\leq 40\%$ of landscaped area

Criteria

1. *Turf $\leq 40\%$ of landscaped area*

Install turf grass on 40% or less of the landscaped area.

2. *Use WaterSense water budget tool to design landscape*

Use the WaterSense water budget spreadsheet to design the landscape to meet the allowable water budget. All landscaped areas should be included when performing the calculations.

Additional Resources

- WaterSense Water Budget Tool: <https://www.epa.gov/watersense/water-budget-tool>

Confirmation

Turf 40% or less of landscaped area

- The EarthCraft Technical Advisor will verbally and visually confirm compliance of criteria with the builder at the final inspection. Calculations may be requested from the Project Team.

WaterSense Water Budget tool

- The Project Manager will review the completed Water Budget spreadsheet provided by the Project Team.

WE 2.5 Vegetate slopes exceeding 4:1

Criteria

Install erosion resistant vegetation on all slopes greater than 4 feet of horizontal run per 1 foot vertical rise, or provide terracing.

Example

Trees, shrubs, taller growing grasses, and wildflowers can be effective plantings for preventing erosion.

Confirmation

- The EarthCraft Technical Advisor will visually confirm compliance of criteria at final inspection.

WE 2.6 If installed, irrigation system

For Platinum projects, all applicable items (1-5) must be achieved.

Criteria

1. *Design, install and audit irrigation system by WaterSense Irrigation Partner with no leaks*

Irrigation system must be designed, installed, and audited by a WaterSense irrigation partner in accordance with the WaterSense program. The system must be checked for leaks by the WaterSense irrigation partner during the post-installation audit.

2. *Micro-irrigation system (e.g. drip irrigation) includes pressure regulator, filter, and flush end assemblies*

If installed, micro-irrigation system (a low-pressure irrigation system that sprays, mists, sprinkles, or drips) includes a pressure regulator, filter and flush end assemblies.

3. *Distribution uniformity $\geq 65\%$ lower quarter*

Irrigation systems must achieve lower quarter distribution uniformity (DU_{LO}) of 65 percent or greater. Measure the distribution uniformity on the largest spray-irrigated area during the post-installation audit.

4. *Install sprinklers only on turfgrass, pop-up height $\geq 4"$*

Install sprinkler heads so that the heads have a 4" or greater pop-up height, matched precipitation nozzles, and check valves. Use sprinkler irrigation on turfgrass only, on strips 4' wide or greater, and slopes less than or equal to 4:1.

5. *Establish grow-in phase and post landscape seasonal water schedules at irrigation controller*

Establish grow-in phase and post landscape seasonal water schedules at irrigation controller

Post two watering schedules developed by the WaterSense irrigation controller at the irrigation controller. The first schedule must address the initial grow-in phase of the landscape and the second schedule must address the established landscape. Both schedules must vary according to the season.

Exemptions

Waivers from this requirement may be available if there are an insufficient number of available WaterSense irrigation partners, proximate to the project site.

Definitions

Distribution uniformity is the measure of uniformity of applied irrigation water over an area. DU_{LO} is the ratio of the average of the lowest 25 percent of measurements to the overall average measurement.

Additional Resources

- A list of WaterSense irrigation partners is available at: <https://lookforwatersense.epa.gov/pros/>

- Auditing procedures are described in the Irrigation Audit Guidelines for WaterSense Labeled New Homes at: [Guidelines for Irrigation Audits | Water Sense](#)

Confirmation

- The EarthCraft Technical Advisor will visually confirm compliance of criteria at final inspection.

Items 1 and 3 only

- The builder must submit documentation demonstrating compliance of criteria to the EarthCraft Technical Advisor at the final inspection.
- The EarthCraft Technical Advisor will review documentation provided by the builder for compliance of criteria.

WE 2.7 Drought-tolerant/native landscaping turf and plants

Criteria

Install 75% or more drought-tolerant/native landscaping turf and plants.

Example

100% of the turf installed is drought tolerant. 30 individual plants of a native species are installed, as well as 5 individual plants of a non-native, non-drought tolerant species. Both the plants and the turf are over 75% drought-tolerant/native so the project achieves this credit.

Clarification

The turf and plants must each meet or exceed 75% drought tolerant/native. If only one meets it, points can not be earned.

Additional Resources

- [Native Plants for Conservation, Restoration and Landscaping - Native Plant Finder](#)

Confirmation

- The EarthCraft Technical Advisor will verbally and visually confirm compliance of criteria with the builder at the final inspection.

WE 2.8 Test and amend soil

Criteria

Test soil using a soil testing kit from the local cooperative extension office or other reliable source such as a garden supply store. Till and amend soil as needed to provide the appropriate balance of nutrients, pH, organic material content, and percolation based on designed landscape. Till soil 3-6 inches deep.

Additional Resources

- <https://www.soiltest.vt.edu/>

Confirmation

- The builder must submit documentation demonstrating compliance of criteria to the EarthCraft Technical Advisor at the final inspection.
- The EarthCraft Technical Advisor will review documentation provided by the builder for compliance of criteria.

WE 2.9 Irrigation

Criteria

1. *Greywater irrigation system*

Install a greywater system for landscape irrigation. The system must be approved by local building and/or health department, include a tank or dosing basin, and collect water from a minimum of the clothes washer or shower.

2. *Rainwater irrigation system*

Design and install a rainwater harvesting and storage system for landscape irrigation. Size the storage system to hold water from a 1" rainfall event (0.62 gallons per square foot) from 50% or greater of the total roof area of the building.

3. *Zone irrigation system for specific water needs in each planting area*

Design irrigation system with zones based on water needs in each planting area. Attention should be given to the sprinklers at the tops and bottoms of sloped areas to prevent runoff. Micro Irrigation should be installed on separate zones from the rest of the irrigation system if sprinkler heads are used in other parts of the landscape.

4. *Provide weather station or soil moisture sensor on irrigation system*

Equip irrigation systems with technology that inhibits or interrupts operation of the irrigation system during periods of rainfall or sufficient moisture (e.g., rain sensors, soil moisture sensors).

Clarifications

For multifamily projects, water captured from HVAC condensate drain may be used to meet the intent of #2 listed above.

WE 2.10 Timer on exterior water spigots

Criteria

Install timer on all exterior water spigots.

Confirmation

- The EarthCraft Technical Advisor will visually confirm compliance of criteria with the builder at the final inspection.

Education and Operations (EO)

Education (EO 1)

EO 1.0 Provide property management with project-specific owner's manual

Criteria

Provide property management with project-specific owner's manual. Manual must contain, at a minimum, the following information:

- General
 - The final EarthCraft Worksheet for the project with cover sheet, and a copy of the EarthCraft certificate for the project.
- Energy Efficient Systems
 - Instructions for the proper use and maintenance of all energy-using systems, including, but not limited to:
 - Exhaust fans (kitchen range, bath, etc.)
 - Fireplaces
 - HVAC systems including filters, whole-house ventilation and thermostats
 - Water heaters
- Education and Operations
 - Provide at least three additional green activities such as recycling, proper management of hazardous waste disposal, gardening, the use of healthy cleaning materials, alternative measures to pest control, neighborhood conveniences to facilitate a healthy lifestyle and the purchase of green power.
 - Recycling information must include recycling facilities conveniently located to the project as well as a list of haulers that provide curbside service.
- Credit Specific Items requiring operating manuals/instructions:
 - DU 1.14 Alternative termite treatment with no soil pretreatment
 - ES 4.2 Install outside air intake with ventilation CFM, damper and controls meeting ASHRAE 62.2-2010 ventilation requirements
 - ES 4.17 Automatic bathroom exhaust fan controls
 - WE 2.1.2 & 2.1.3 Irrigation system
 - EO 3.1 Indoor airPLUS
 - EO 3.2 WaterSense New Home
- Credit Specific Items requiring warranty information:
 - DU 1.14.3 Mold inhibitor with warranty applied to all lumber
 - DU 1.17 Exterior cladding with 30-year warranty
 - DU 1.18 Windows, doors and skylights with ≥ 25-year warranty
 - DU 1.21-A & B Roofing warranty

Clarifications

Equipment manuals are acceptable but must be supplemented with clear and specific instructions to the tenant and property management on when and how equipment should be used and maintained.

Detailed information on credit specific items is located under that line item in the guidelines.

Additional Resources

For templates of guides that not only list the environmental features of the units but also explain their intent, benefits and maintenance, see:

- [Enterprise Green Communities Templates for Certification](#) | [Enterprise Green Communities Templates for Certification](#) (Permalink)

Confirmation

- The builder must present documentation demonstrating compliance of criteria to the EarthCraft Technical Advisor at the final inspection.
- The EarthCraft Technical Advisor will review documentation provided by the builder for compliance of criteria.

EO 1.1 Local recycling contact

Criteria

Provide residents a location for local recycling if recycling is not collected on site.

Clarification

The project team will not achieve points if recycling is completed by the local municipality or if the project team provides a recycling center on site.

Confirmation

- The EarthCraft Technical Advisor will review documentation provided by the project team for compliance with criteria.

EO 1.2 Community Recycling Facility

Criteria

Provide on-site recycling services for residents.

Confirmation

- Contract / Facilities located on site include recycling dumpster.

EO 1.3 Household hazardous waste resources

Criteria

The property management team must provide the tenant with a copy of hazardous cleaning material products and suggest environmentally preferable alternatives to common but harmful cleaning products.

Property management must include environmentally preferable products in their own protocols for purchase of cleaning supplies.

Confirmation

- The project team must present documentation demonstrating compliance with criteria to the EarthCraft Technical Advisor prior to the final inspection.

Operations and Management (EO 2)

EO 2.0 Provide all subcontractors with EarthCraft Multifamily worksheet

Criteria

Provide and review the relevant EarthCraft Multifamily measures with each subcontractor to ensure their compliance with the program guidelines.

Confirmation

- The EarthCraft Technical Advisor will verbally confirm compliance with criteria with the project team at the pre-drywall and final inspections.

EO 2.1 Property Maintenance Staff representative attends design review and/or kick off meeting

Criteria

Property Maintenance Staff representative attends design review and/or kick off meeting.

Confirmation

- The EarthCraft Technical Advisor will verbally confirm compliance with criteria with the project team at the design review and/or kick off meeting

EO 2.2 Market EarthCraft Multifamily program

Criteria

Include the EarthCraft Multifamily logo in all print materials, websites, advertisements and other promotional materials associated with project promotion.

Post an EarthCraft Multifamily sign during construction that is visible from the site entrance.

Confirmation

- The EarthCraft Technical Advisor will verbally and visually confirm compliance with criteria with the project team at the pre-drywall and final inspections.

EO 2.3 Provide pre-occupancy briefing for tenant

Criteria

Provide Operations and Maintenance package to the tenant. Include product **manufacturers' manuals for all installed equipment, fixtures, and appliances** as well as operations and maintenance guidance for space heating and cooling equipment, mechanical ventilation equipment and humidity control equipment. Provide 30-minute walk-through of dwelling unit with identification of and instruction in operation and maintenance of all installed equipment.

Additional Resources

[Tools to Engage Residents in Green Living - Enterprise](#)

Confirmation

- The EarthCraft Technical Advisor will collect written materials associated with pre-occupancy briefing

EO 2.4 Project participates in post occupancy project debriefing

Criteria

Project team (maintenance, management staff, and owner) participates in post occupancy project debriefing to review the final worksheet and primary green building features of the project.

Confirmation

- The EarthCraft Technical Advisor will verbally confirm compliance with criteria with the project team upon attendance at post occupancy project debriefing.

EO 2.5 Environmental management and building maintenance guidelines for property management staff

Criteria

The property management group must develop and utilize maintenance guidelines related to the green features of the project. These features must include all energy and water efficiency features of the units and common spaces. The goal of these guidelines will be to promote improved maintenance of the building's sustainable features.

Additional Resources

- [Enterprise Green Communities Templates for Certification](#) | [Enterprise Green Communities Templates for Certification](#) (Permalink)

Confirmation

- The project team must present management guideline documentation demonstrating compliance with criteria to the EarthCraft Technical Advisor at the final inspection.

EO 2.6 Landscape maintenance guide for maintenance and management personnel

Criteria

The property management group must develop and utilize landscape maintenance guidelines for maintenance and management staff. The goal of these guidelines will be to promote proper maintenance of the landscaping.

Confirmation

- The project team must present the landscape management guideline documentation demonstrating compliance with criteria to the EarthCraft Technical Advisor at the final inspection.

Third Party Programs (EO 3)

EO 3.0 ENERGY STAR Multifamily New Construction Certification

Criteria

Construct and certify project in accordance with current ENERGY STAR Multifamily New Construction specifications. Complete all necessary steps to qualify project under ENERGY STAR, including all checklists and inspections.

Clarifications

Project team must be an active ENERGY STAR Partner.

Additional Resources

For more information about ENERGY STAR Multifamily New Construction see:

https://www.energystar.gov/partner_resources/residential_new/homes_prog_reqs/multifamily_national_page



Confirmation

- The project team must submit the ENERGY STAR Multifamily New Construction certificates for the project.

EO 3.1 Indoor airPLUS

Criteria

Construct and certify project in accordance with Indoor airPLUS guidelines. Complete Indoor airPLUS Verification Checklist and include a copy in the project-specific owner's manual.

Additional Resources

[EPA Indoor airPLUS](#)

Confirmation

- The project team must submit the Indoor airPLUS certificates for the project prior to ECMF Certification.

EO 3.2 WaterSense New Homes

Criteria

To label a project as a WaterSense New Home, the builder must sign a WaterSense partnership agreement, build the project to WaterSense specifications, submit the project for inspection by a certified WaterSense Inspector, and pass inspection. The builder must also complete WaterSense Labeled New Home Inspection Checklist.

Include the following in the project-specific owner's manual:

- Information for all water-using equipment or controls installed and relevant WaterSense materials on indoor and outdoor water use.

- If installed, a record drawing (schematic) of the irrigation system, an itemized list of irrigation components, copies of irrigation schedules, and information about reprogramming the irrigation schedule after the establishment of the landscape.
- General information on water-efficient appliances.

Additional Resources

For more information about EPA's Water Sense Homes program see:
<https://www.epa.gov/watersense/homes>

Confirmation

- The builder must provide the WaterSense certificates for the project prior to ECMF Certification.

EO 3.3 EarthCraft Community Certification

Criteria

Build the project in an EarthCraft Community.

Clarifications

Community must either be actively pursuing EarthCraft Communities certification or be a certified EarthCraft Community. An alternate communities level certification will be considered on a case by case basis.

Additional Resources

For more information, visit www.viridiant.org or <https://earthcraft.org/>.

Confirmation

- The EarthCraft Technical Advisor will verbally confirm compliance with criteria with the project team at the final inspection.

EO 3.4 EarthCraft Light Commercial for Community Center

Criteria

Certify the project's Community Center under the EarthCraft Light Commercial program.

Additional Resources

For more information, visit <https://earthcraft.org/programs/earthcraft-light-commercial/>

Confirmation

- The EarthCraft Technical Advisor will confirm EarthCraft Light Commercial certification achieved at the final inspection.

EO 3.5 EarthCraft Light Commercial Ready Spaces

Criteria

For mixed-use developments that include both residential units and commercial retail spaces sharing the same building shell, meet the following criteria in order to designate the retail tenant spaces as EarthCraft Light Commercial Ready (ECLC Ready):

Clarification

All projects that intend to seek ECLC Ready Spaces must pre-qualify with an EarthCraft Light Commercial approved EarthCraft Technical Advisor.

Additional Resources

- For more information on meeting ASHRAE referenced standards and minimum envelope requirements for light commercial spaces, refer to the EarthCraft Light Commercial Technical Guidelines, downloadable for free at: <https://earthcraft.org/programs/earthcraft-light-commercial>
- [COMCheck Download](#)

Confirmation

- Provide applicable signed COMcheck compliance certificates and COMcheck File prior to Pre-Construction Meeting
- Provide Certificate of Compliance for storefront glass (as applicable)
- Pre-drywall and Final Inspections by an EarthCraft Light Commercial approved EarthCraft Technical Advisor to view air sealing measures, applied insulation, glazing, and installed ductwork

EO 3.6 DOE Zero Energy Ready Home

Criteria

Construct and certify project according to the requirements of the DOE's Zero Energy Ready Home Certification (ZERH).

Additional Resources

For more information, see:

- <https://www.energy.gov/eere/buildings/guidelines-participating-doe-zero-energy-ready-home-program>

Confirmation

- The project must meet all Energy Modeling Criteria associated with the ZERH Certification
 - The EarthCraft Project Manager will review documentation provided by the project team for compliance of criteria.
-

Innovation (IN)

Innovation

IN 1.0 On-site fuel cell or cogeneration system

Criteria

Install on-site fuel cell or cogeneration system to provide energy (in the form of heat and/or electricity) to project.

Confirmation

- The EarthCraft Technical Advisor will visually confirm compliance with criteria at final inspection.

IN 1.1 Solar-ready design

Criteria

Design and construct project with the intent of being retrofitted with solar hot water and/or solar power. There must be space on lot for a solar power array that can produce, at minimum, 20% of building(s) electrical load. The space must allow the array to remain un-shaded year-round, be oriented to within 15 degrees of true south, and be angled horizontally within 15 degrees of latitude.

Install and label conduits from the mechanical room and water heater to the attic.

Install extra plumbing valves and fittings on the water heater and an electrical outlet at the planned solar tank location.

Construction plans must designate future component (solar power and solar hot water) locations.

Confirmation

- The project team must present documentation demonstrating compliance with criteria to the EarthCraft Technical Advisor at the pre-drywall inspection.
- The EarthCraft Technical Advisor will review documentation provided by the project team for compliance with criteria and will visually confirm compliance at pre-drywall and final inspections.

IN 1.2 Solar electric system (10% of project demand)

Criteria

The project will utilize a solar electric array with the capacity to offset 10% of electrical load demand required by all building(s) within the development. This power may be directly tied to the building(s) common areas and units or may be transferred to the grid.

Clarifications

To qualify, the project team must clearly indicate the expected electrical load requirements of the building(s) within the development and then provide a solar PV design showing that 10% of that demand is attainable.

Efficient lighting strategies (outlined in IES/ASHRAE design guidelines, see ES 7.2) are encouraged as a first step, in order to reduce the overall electrical load requirement before installing the required 10% PV capacity at final design.

Confirmation

- The project team must present documentation demonstrating compliance with criteria to the EarthCraft Technical Advisor.

The documentation must include:

1. A letter from the solar designer/installer indicating the kwh production of the solar system installed.
2. The electrical engineer must indicate the total expected electric capacity of the entire building(s) in the project.
3. If tied to the grid, the project team must provide details of the agreement with the power provider.

IN 1.3 100% of stormwater kept on site and used for development operations

Criteria

The project prevents 100% of the stormwater from entering the main sewer system by storing it on site to be used in the building/development operations.

Clarifications

To qualify, all stormwater must be stored on site and used in the building/development operations.

Confirmation

- The EarthCraft Technical Advisor will visually confirm compliance with criteria at final inspection.

IN 1.4 Common areas use solar electric system (80% of demand)

Criteria

The project will utilize a solar electric array with the capacity to offset 80% of electrical load demand required by all common areas within the building(s). This power may be directly tied to the building or may be transferred to the grid.

Clarifications

To qualify, the project team must clearly indicate the expected electrical load requirements of all common areas (including but not limited to clubhouses, offices, hallways, laundry facilities, bathrooms, outdoor common areas, etc.) and then provide a solar PV design showing that 80% of that demand is attainable.

Efficient lighting strategies and controls (outlined in IES/ASHRAE design guidelines, see ES 7.2) are encouraged as a first step in order to reduce the overall electrical load requirement before installing the required 80% PV capacity at final design.

Confirmation

- The project team must present documentation demonstrating compliance with criteria to the EarthCraft Technical Advisor.

The documentation must include:

1. A letter from the solar designer/installer indicating the kwh production of the solar system installed.
2. The electrical engineer must indicate the total expected electric capacity of all common areas within the project.
3. If tied to the grid, the project team must provide details of the agreement with the power provider.

IN 1.5 Housing affordability

Criteria

A percentage of total housing units within the project are reserved for tenants qualifying for a low-income housing assistance program.

A. ≥20% total units

B. ≥50% total units

Confirmation

- The project team will submit details of affordable housing funding mechanism and the numbers of units qualifying as affordable within the entire development.

IN 1.6 Developer contracts for at least 12 months post construction energy monitoring

Criteria

Upon certification, the developer will contract for at least 12 months of post construction energy monitoring and share data with Viridiant.

Clarifications

- At minimum, track monthly electric and gas usage in the number of units necessary to meet the sample size:
 - 50% of each unit size in developments with 50 units and less
 - 30% of each unit size in developments with 51-120 units
 - 25% of each unit size in developments with 121+ units
 - 100% of meters within master-metered buildings
- Within 24 months of 100% lease-up, provide 12 months of continuous utility data for each unit in the sample set.
 - If any unit is vacant for 2 or more months, it must be replaced with an occupied unit of the same bedroom type to keep meeting the sample set requirements.
 - Subsequent projects by the Developer/Owner will not be able to earn these points if this is not met.
- As necessary, obtain tenant utility release forms and provide them to the Provider that is being used to meet one of the below options. Through lease or lease addendum, tenants agree to release their utility information and provide the necessary details (e.g. utility account number, last 4 of social) to obtain that information from the utility company.
- Demonstrate that an option for complying has been selected and setup has begun for the minimum sample set.

Confirmation

- The EarthCraft Technical Advisor will confirm compliance and the developer will share the collected data with Viridiant upon completion.

IN 1.7 Project-specific innovation points

Criteria

Prior to certification, submit specifications for innovative products, or design features to EarthCraft for approval to qualify for additional points.

Confirmation

- The EarthCraft Technical Advisor will submit to EarthCraft for approval and point award.